

Yalıtımsız Sürme Serisi Açılım Varyasyonları

Noninsulated Sliding Serie Opening Variations

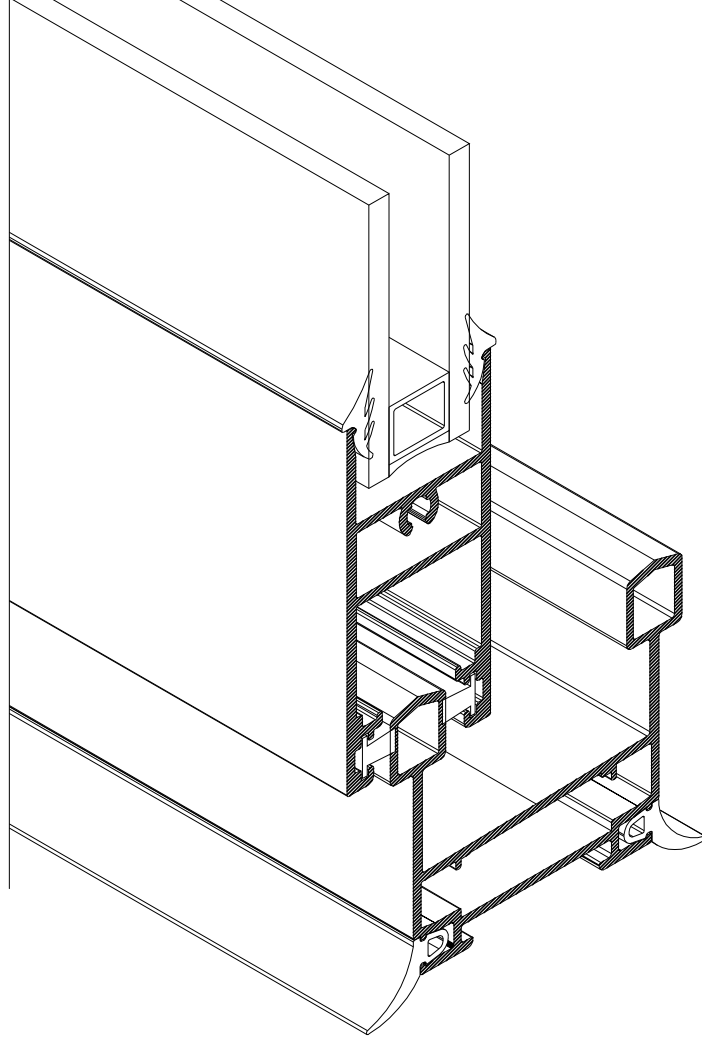
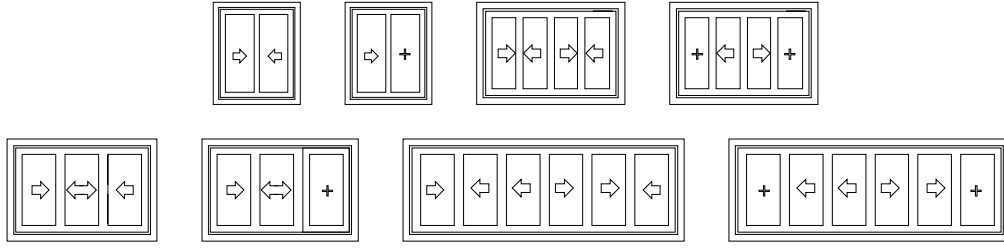

S4

S40 Yalıtımsız Sürme Serisi
S40 Noninsulated Sliding Serie

Alaşım Özellikleri
Alloy Properties













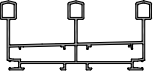

EN AW 6060 (AlMgSi0,5 F22) EN AW 6063(AlMg0,7Si F22)

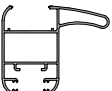
Üretim ve Mekanik Standartları
Production and Mechanical Standards

EN 12020-2 - EN 755-9 - EN 755-2

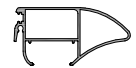
S4

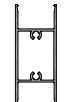
ÜRÜN TEKNİK ÖZELLİKLERİ
PRODUCT'S TECHNICAL FEATURES

PROFİL KESİTİ PROFILE VIEW	PROFİL NO PROFILE NO	PROFİL AÇIKLAMASI PROFILE DESCRIPTION	gr/m	PROFİL KESİTİ PROFILE VIEW	PROFİL NO PROFILE NO	PROFİL AÇIKLAMASI PROFILE DESCRIPTION	gr/m
	S4-101 (48.2 - 58)	KASA PROFİLİ FRAME	1065		S4-503 (20.1 - 6.7)	KANAT PROFİLİ CASEMENT PROFILE	101
	S4-102 (48.2 - 105)	KASA PROFİLİ FRAME	1799		S4-504 (28.4 - 19.2)	ADAPTÖR PROFİLİ ADAPTER PROFILE	241
	S4-201 (48.2 - 58)	KANAT PROFİLİ CASEMENT PROFILE	1016		W1-508 (4.2 - 19)	TIJ PROFİLİ PUSHING ROD PROFILE	138
	S4-202 (60.5 - 74.5)	KANAT PROFİLİ CASEMENT PROFILE	1314		SC0307 (55 - 55) (9.71 mm)	KÖŞE BİRLEŞTİRME CORNER CLEATS	1737
	S4-203 (45.9 - 40.2)	KANAT PROFİLİ CASEMENT PROFILE	785		S4-505 (19 - 35.2)	ADAPTÖR PROFİLİ ADAPTER PROFILE	421
	S4-204 (80.9 - 40.2)	KANAT PROFİLİ CASEMENT PROFILE	1119				
	S4-205 (63 - 28.5)	KANAT PROFİLİ CASEMENT PROFILE	959				
	S4-206 (70.9 - 28.5)	KANAT PROFİLİ CASEMENT PROFILE	962				
	S4-501 (43.1 - 20)	KANAT PROFİLİ CASEMENT PROFILE	572				
	S4-502 (46.5 - 41.5)	KANAT PROFİLİ CASEMENT PROFILE	504				

Profil değerleri teoriktir. Ağırlık olarak teslimde yapılan tartım geçerlidir.
Profil imalatları TS EN 12020-2 ve TS EN 755-9 toleransı,
Moment değerleri EN 14024'e göre hesaplanmıştır.

Profile values are theoretical pre-shipment weight will be valid.
The tolerances of Profile manufacturing are calculated according to EN 12020-2
and TS EN 755-9; moment values are calculated according to EN 14024.

S4
S40 YALITIMSIZ SÜRME SERİ
S40 NONINSULATED SLIDING SERIES

ÜRÜN TEKNİK ÖZELLİKLERİ
PRODUCT'S TECHNICAL FEATURES

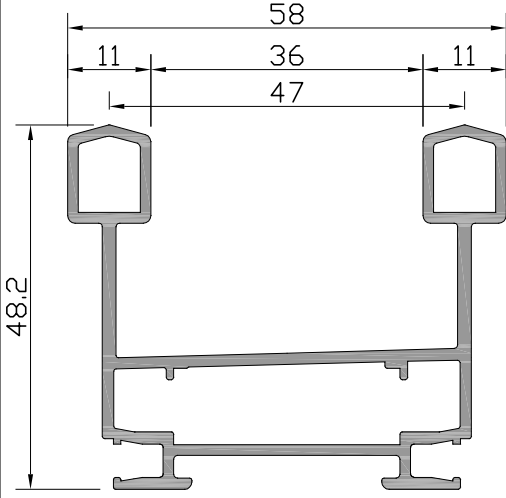

Profil No: S4-101
Ağırlık : 1065 gr/m
lx : 15,54 cm⁴
ly : 8,73 cm⁴

 SC0307-j

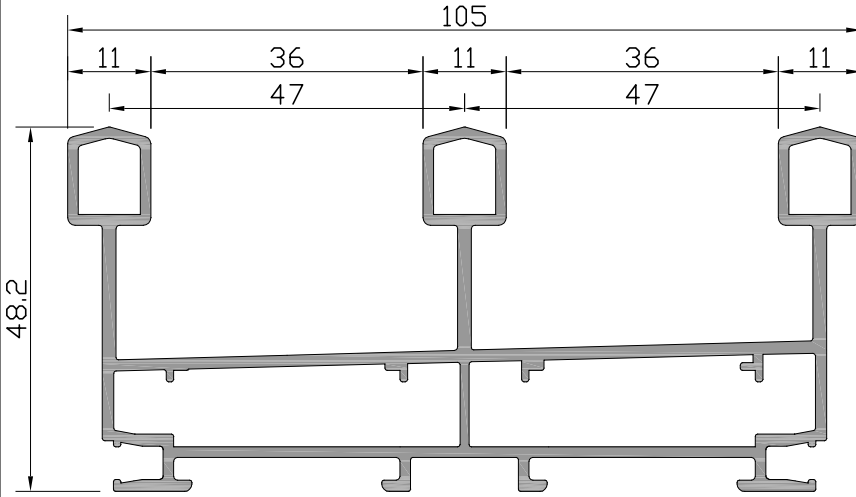

Profil No: S4-102
Ağırlık : 1799 gr/m
lx : 74,90 cm⁴
ly : 13,88 cm⁴

 SC0307-j

S4
S40 YALITIMSIZ SÜRME SERİ
S40 NONINSULATED SLIDING SERIES

ÜRÜN TEKNİK ÖZELLİKLERİ
PRODUCT'S TECHNICAL FEATURES

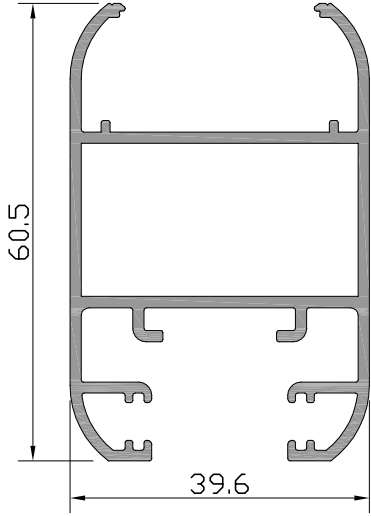

Profil No: **S4-201**
Ağırlık : 1016 gr/m
Ix : 8,84 cm⁴
Iy : 10,73 cm⁴

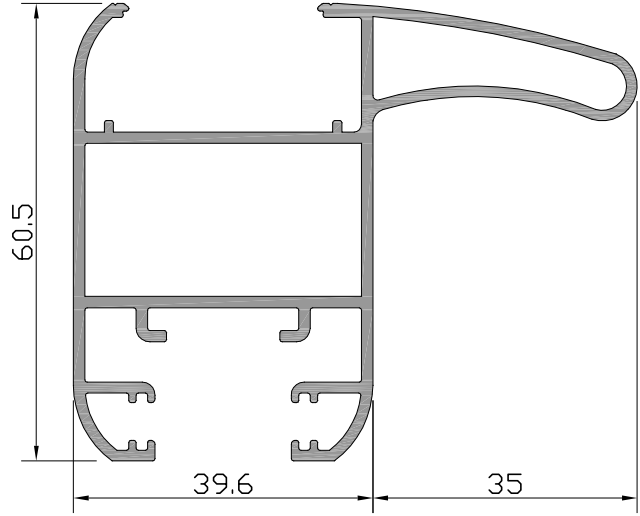

Profil No: **S4-202**
Ağırlık : 1314 gr/m
Ix : 21,76 cm⁴
Iy : 16,31 cm⁴

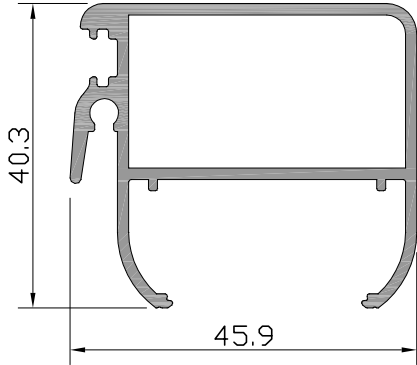

Profil No: **S4-203**
Ağırlık : 785 gr/m
Ix : 7,80 cm⁴
Iy : 4,08 cm⁴

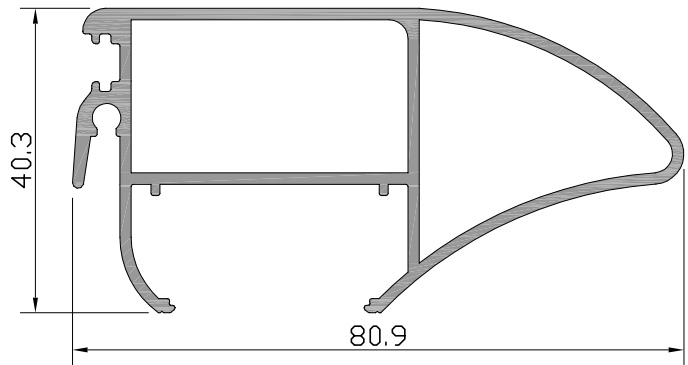

Profil No: **S4-204**
Ağırlık : 1119 gr/m
Ix : 24,00 cm⁴
Iy : 5,53 cm⁴

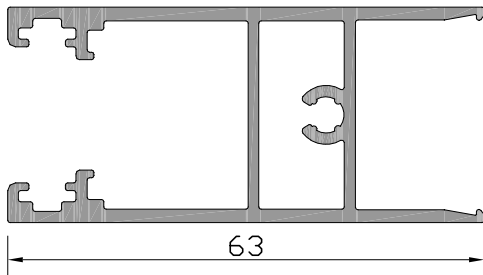

Profil No: **S4-205**
Ağırlık : 959 gr/m
Ix : 4,80 cm⁴
Iy : 10,50 cm⁴

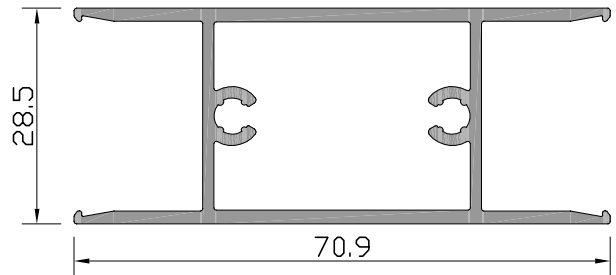

Profil No: **S4-206**
Ağırlık : 962 gr/m
Ix : 4,76 cm⁴
Iy : 12,57 cm⁴

S4
S40 YALITIMSIZ SÜRME SERİ
S40 NONINSULATED SLIDING SERIES

ÜRÜN TEKNİK ÖZELLİKLERİ
PRODUCT'S TECHNICAL FEATURES

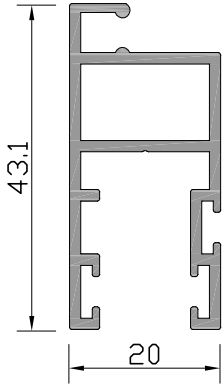

Profil No: S4-501

Ağırlık : 572 gr/m

I_x : 1,29 cm⁴

I_y : 3,24 cm⁴

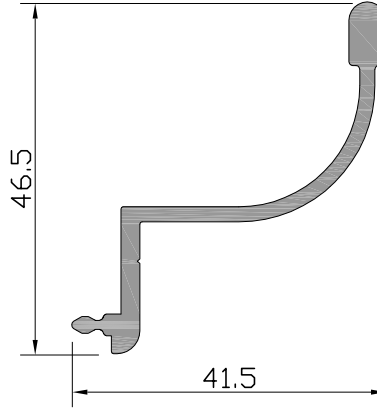

Profil No: S4-502

Ağırlık : 504 gr/m

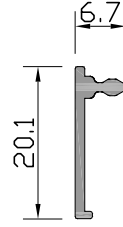

Profil No: S4-503

Ağırlık : 101 gr/m

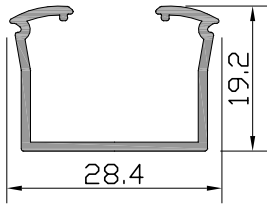

Profil No: S4-504

Ağırlık : 241 gr/m

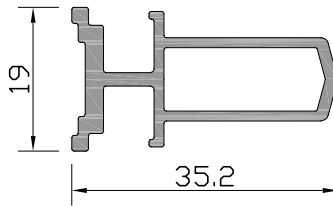

Profil No: S4-505

Ağırlık : 421 gr/m

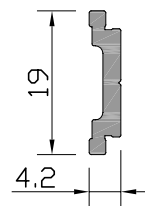

Profil No: W1-508

Ağırlık : 138 gr/m

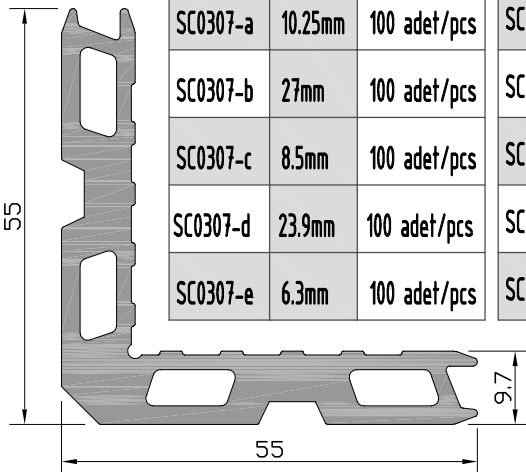

SC0307-a	10.25mm	100 adet/pcs	SC0307-f	25.6mm	100 adet/pcs
SC0307-b	27mm	100 adet/pcs	SC0307-g	6mm	100 adet/pcs
SC0307-c	8.5mm	100 adet/pcs	SC0307-h	4.7mm	100 adet/pcs
SC0307-d	23.9mm	100 adet/pcs	SC0307-ı	26.28mm	100 adet/pcs
SC0307-e	6.3mm	100 adet/pcs	SC0307-j	29.5mm	100 adet/pcs

Profil No: SC0307

Ağırlık : 1737 gr/m

S4

S40 YALITIMSIZ SÜRME SERİ

S40 NONINSULATED SLIDING SERIES

YAN BİTİM - ORTA KAYIT DETAYI

WALL CONNECTION - MULLION DETAIL

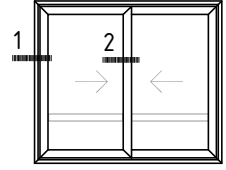

2 raylı sistem detayları
Double rail system details

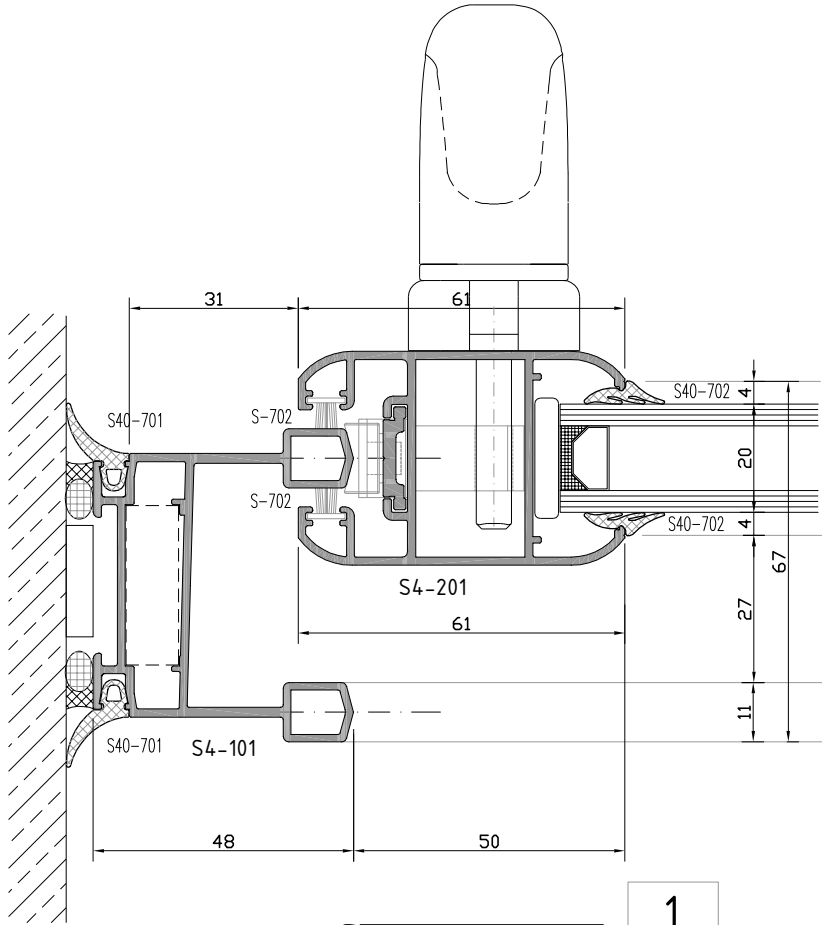

1

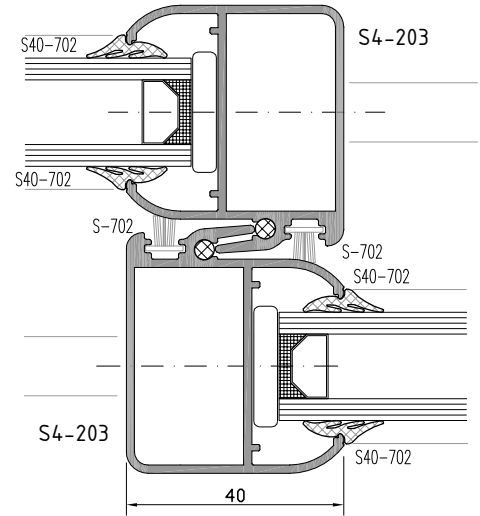

2a

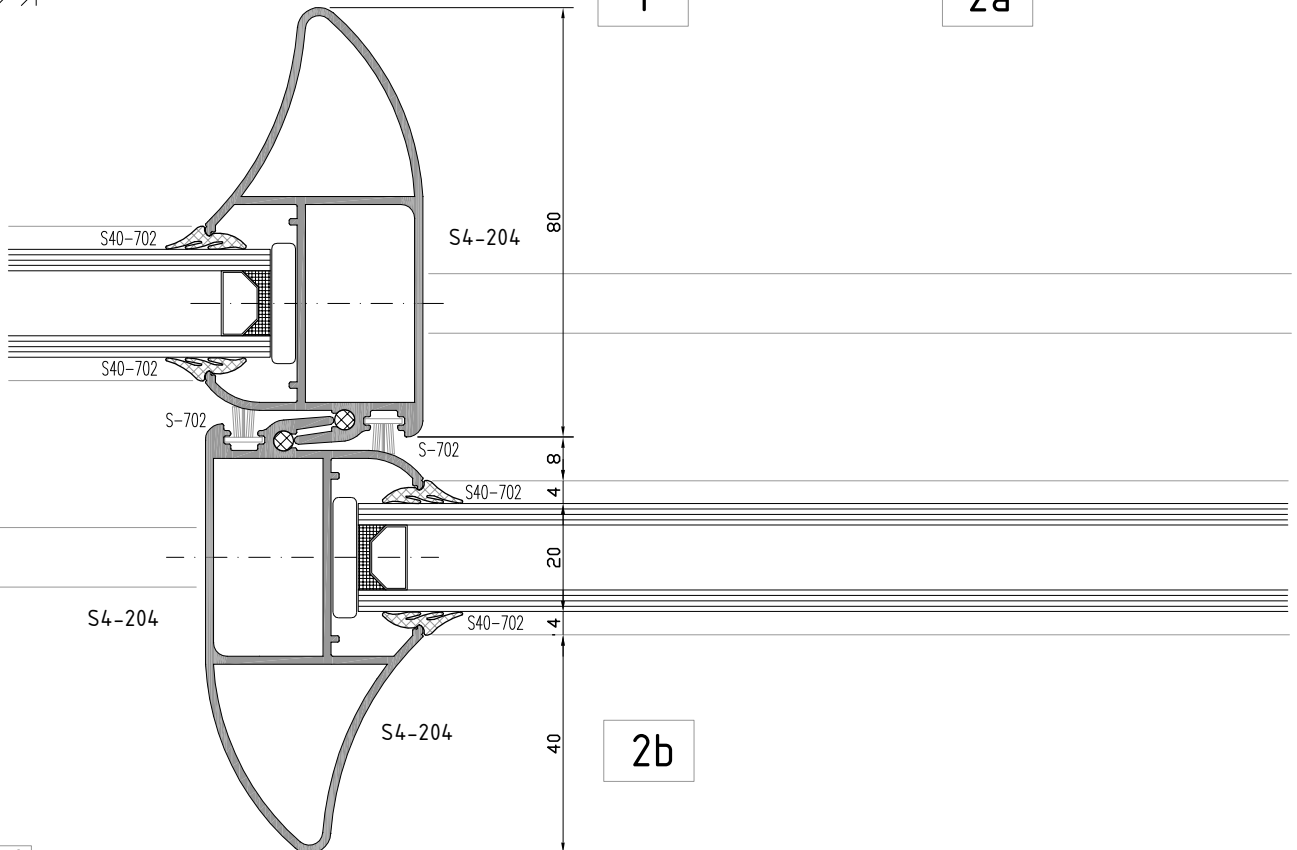

2b

not to scale

S4

S40 YALITIMSIZ SÜRME SERİ

S40 NONINSULATED SLIDING SERIES

YAN BİTİM - ORTA KAYIT DETAYI

WALL CONNECTION - MULLION DETAIL

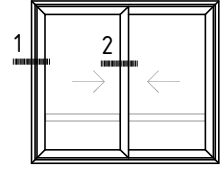

2 raylı sistem detayları
Double rail system details

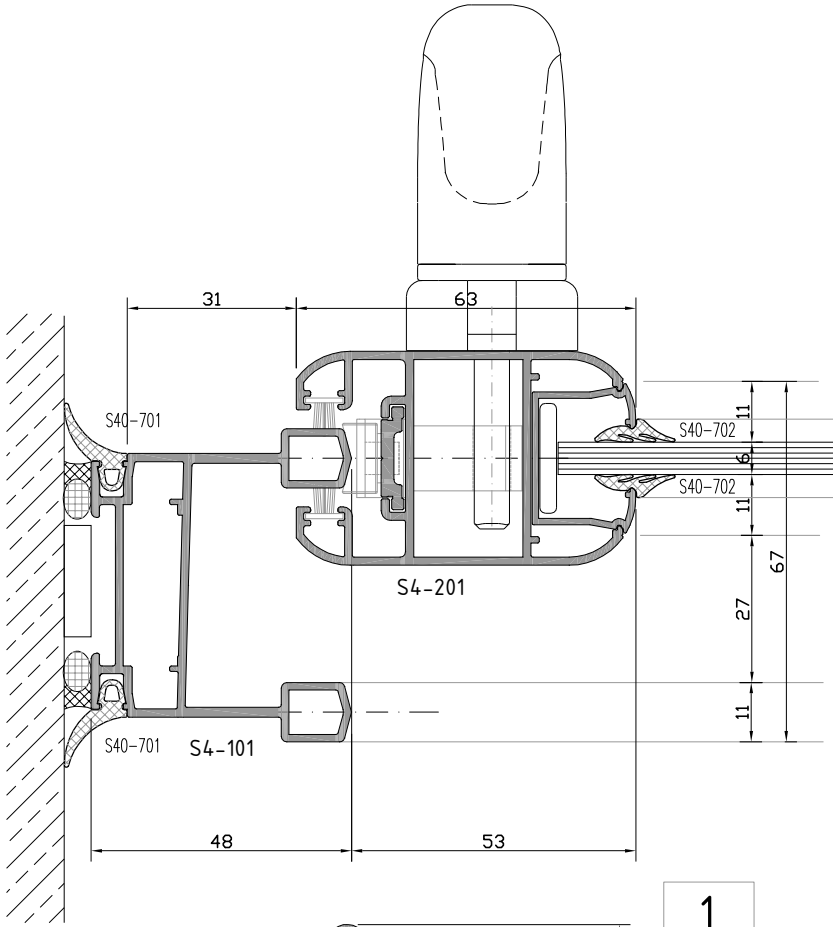

1

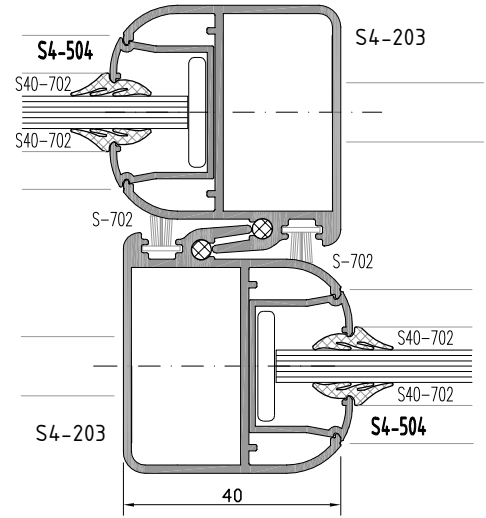

2a

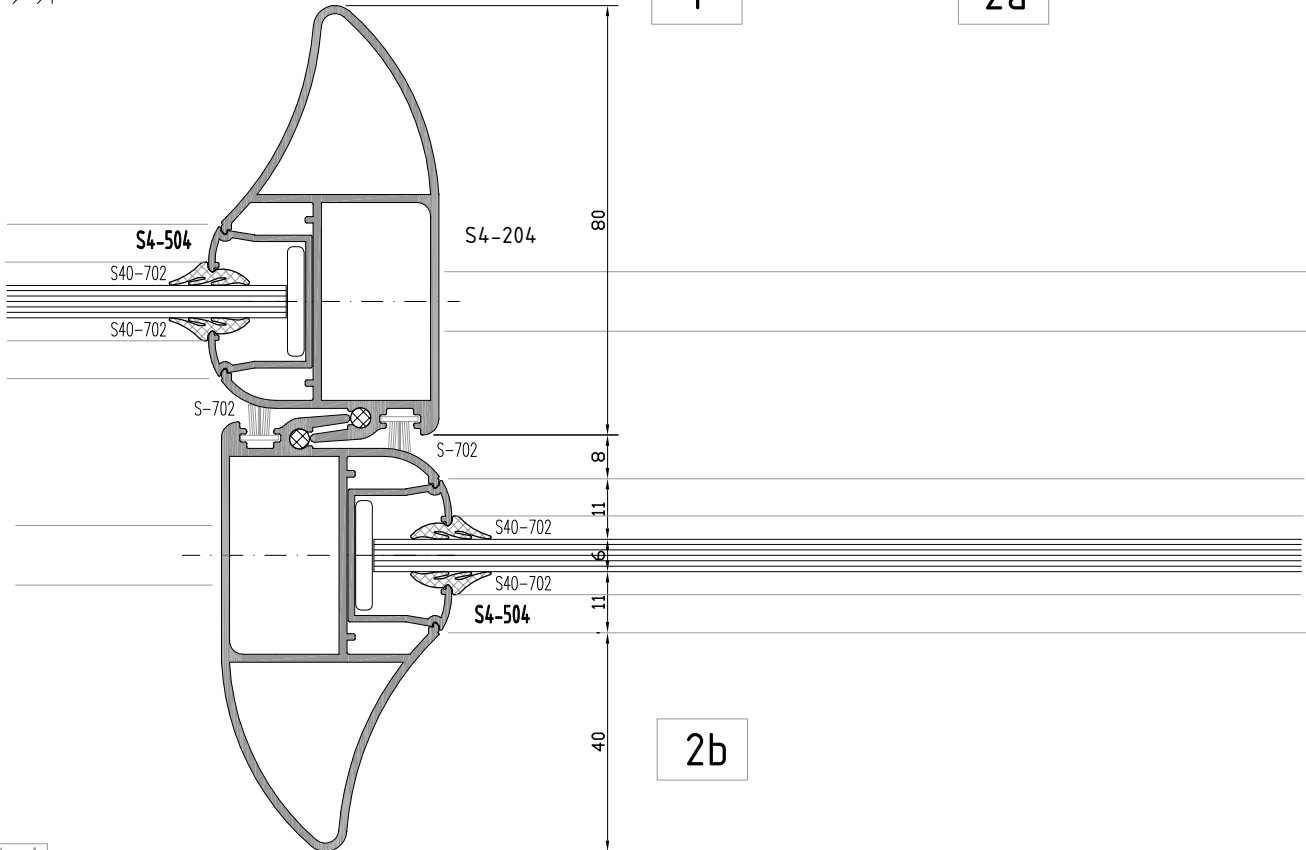

2b

not to scale

S4

S40 YALITIMSIZ SÜRME SERİ

S40 NONINSULATED SLIDING SERIES

ÜST BİTİM-KANAT BİRLEŞİM DETAYI

TOP EDGE - CASMENT JOINING DETAIL

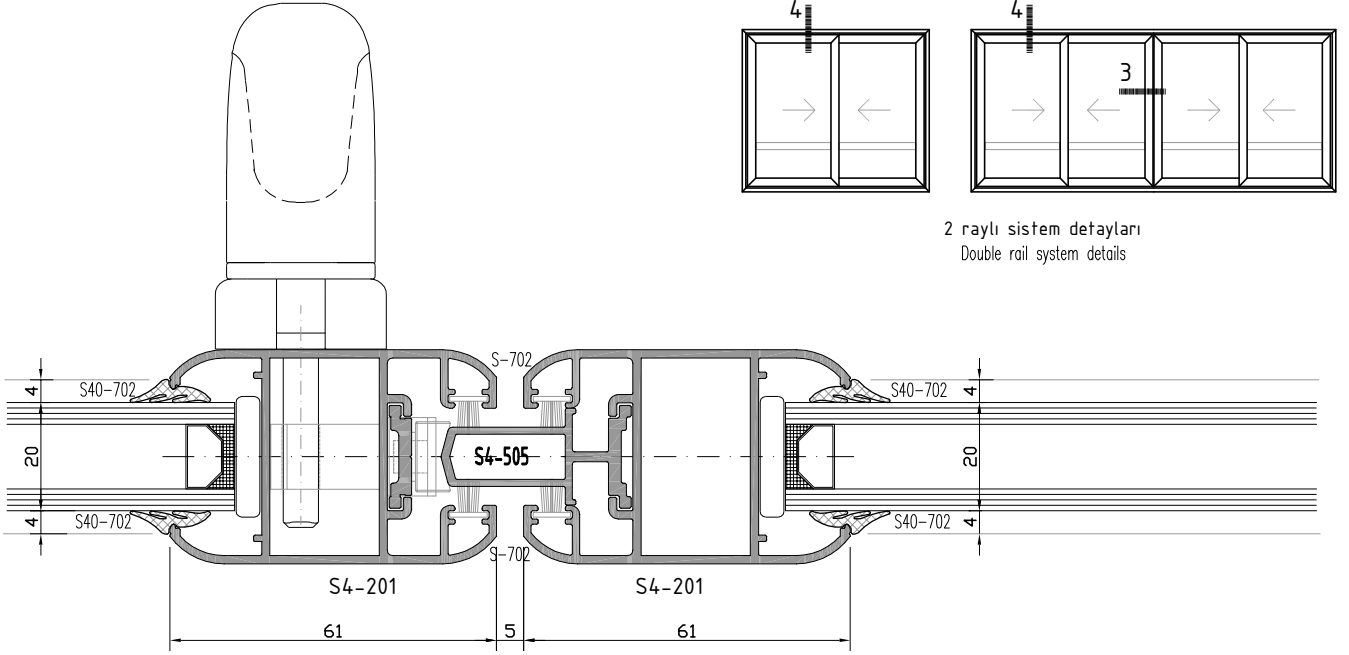

3

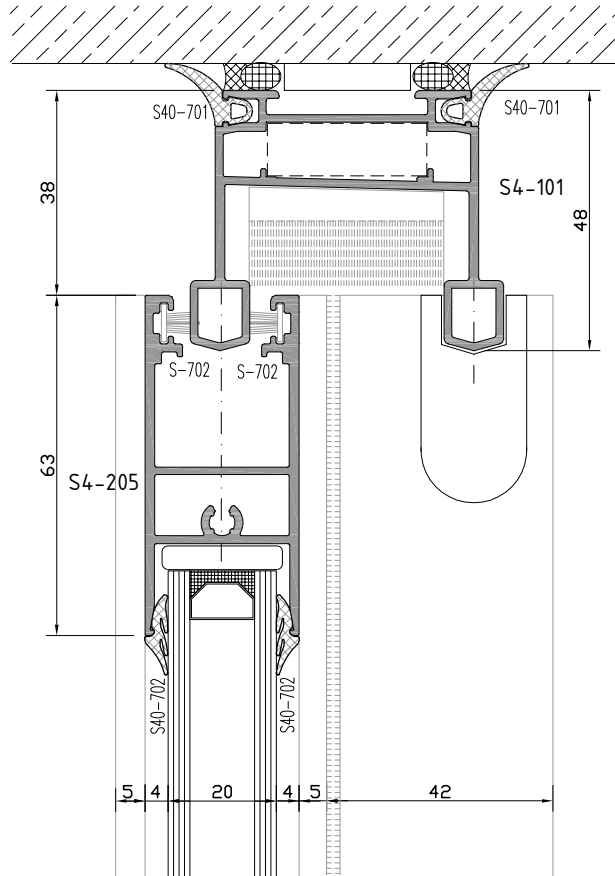

4

not to scale

S4

S40 YALITIMSIZ SÜRME SERİ

S40 NONINSULATED SLIDING SERIES

ALT BİTİM - ORTA KAYIT DETAYI
BOTTOM EDGE - MULLION DETAIL

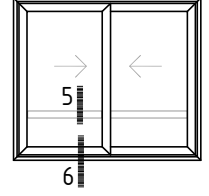
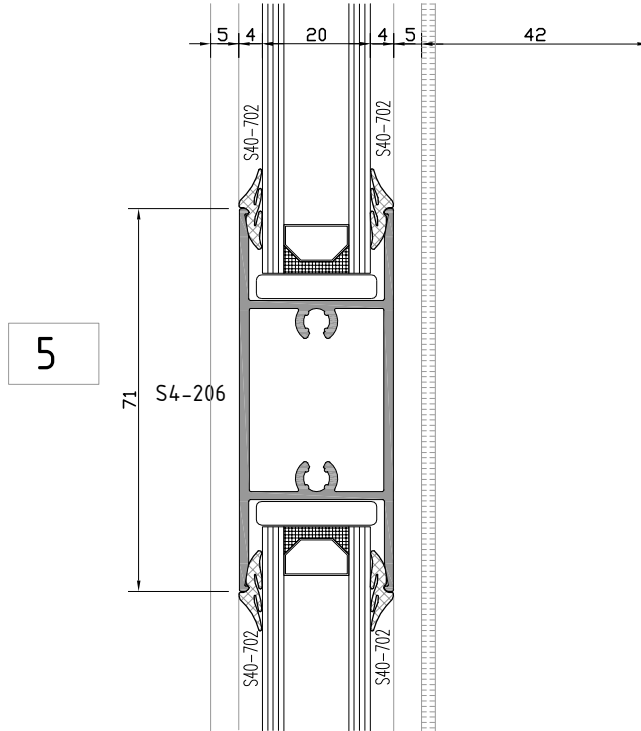

2 raylı sistem detayları
Double rail system details

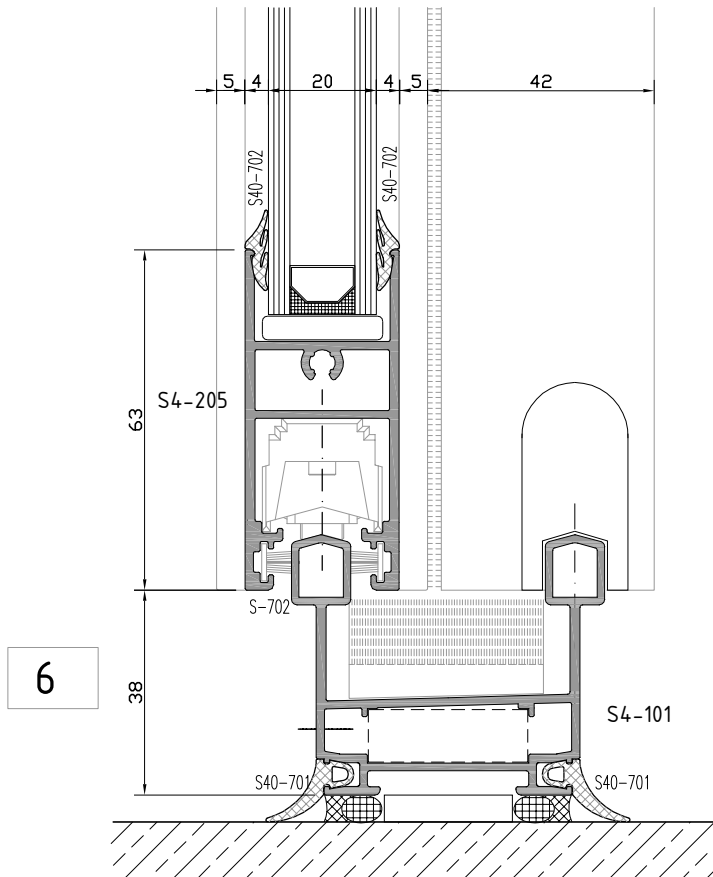

S4

S40 YALITIMSIZ SÜRME SERİ

S40 NONINSULATED SLIDING SERIES

YAN BİTİM - ORTA KAYIT DETAYI
WALL CONNECTION - MULLION DETAIL

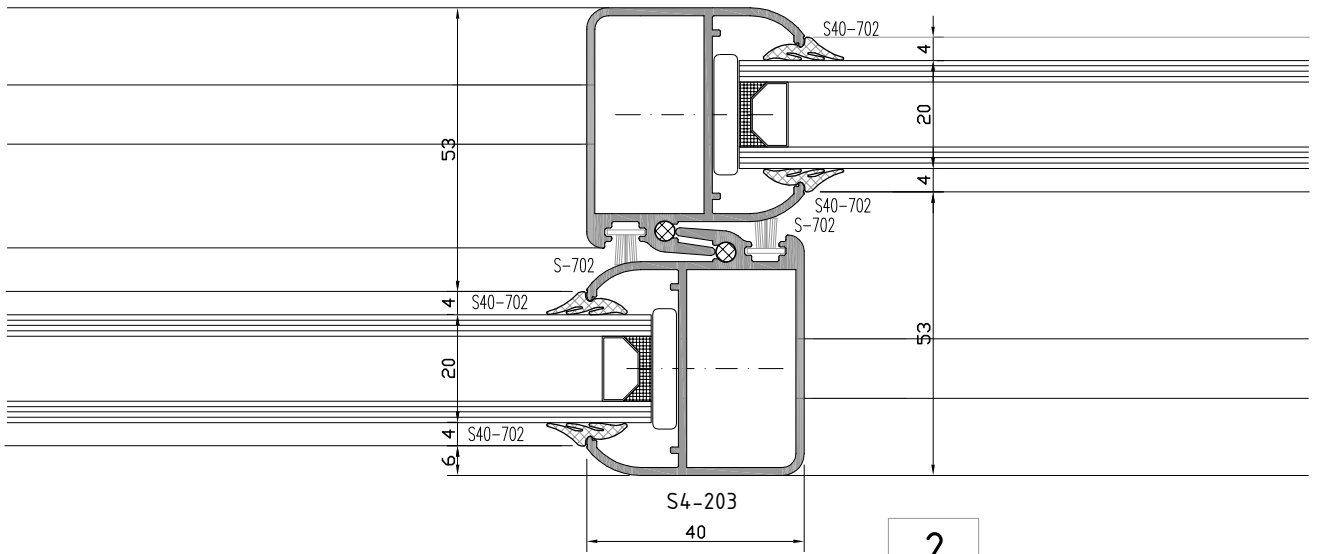
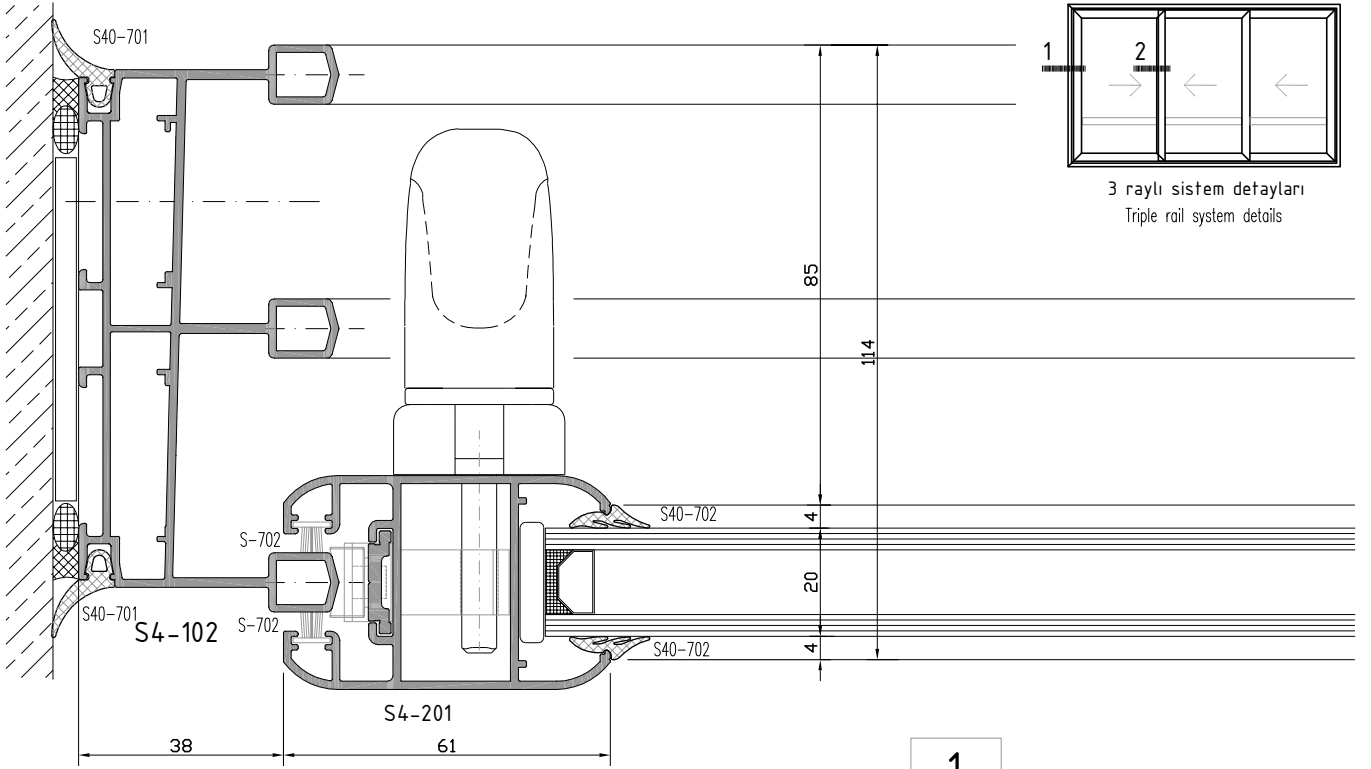

not to scale

S4

S40 YALITIMSIZ SÜRME SERİ

S40 NONINSULATED SLIDING SERIES

YAN BİTİM - ORTA KAYIT DETAYI
WALL CONNECTION - MULLION DETAIL

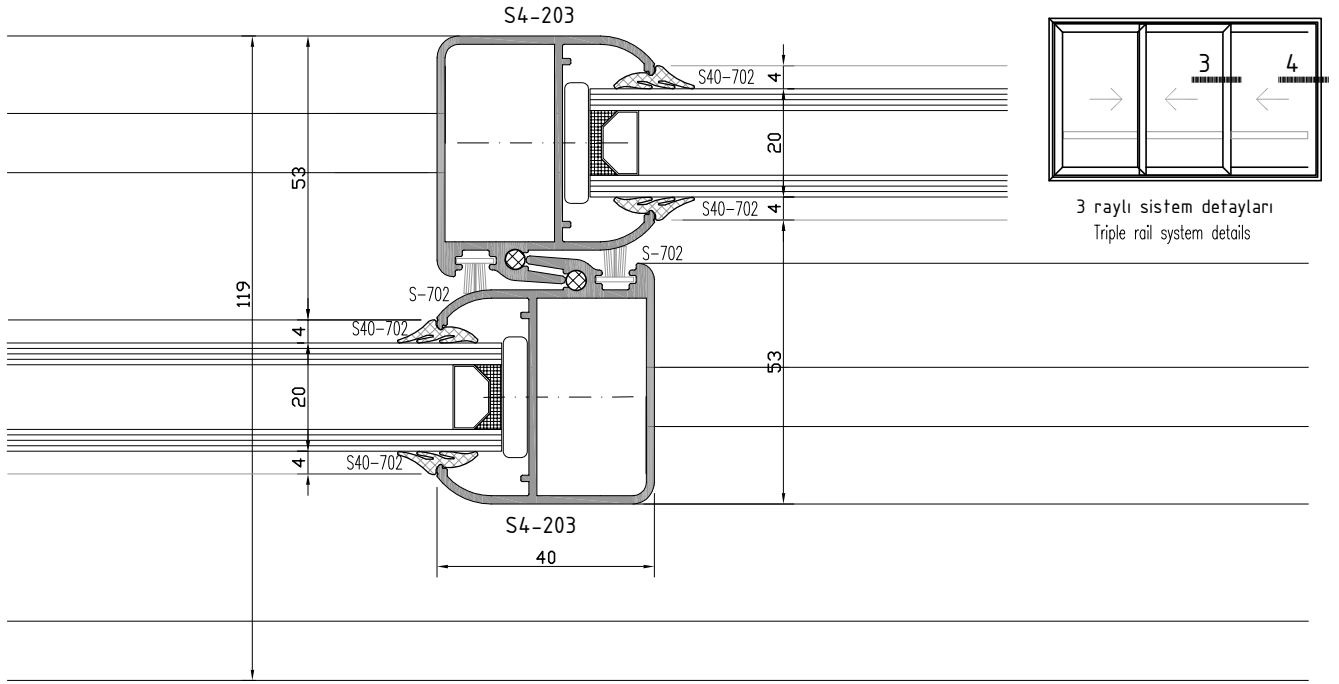

3

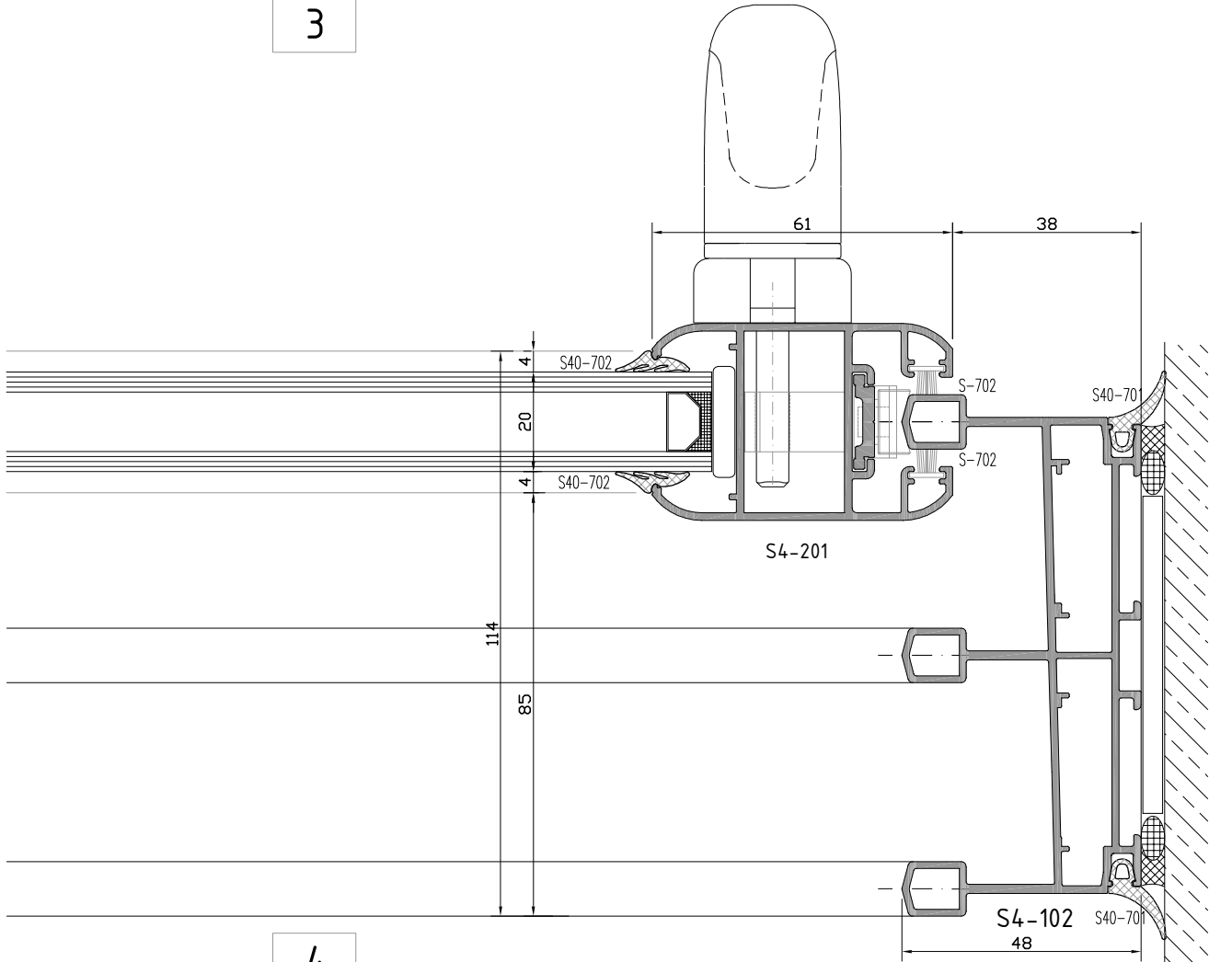

not to scale

S4

S40 YALITIMSIZ SÜRME SERİ S40 NONINSULATED SLIDING SERIES

ÜST BİTİM - ALT BİTİM DETAYI
TOP EDGE - BOTTOM EDGE DETAIL

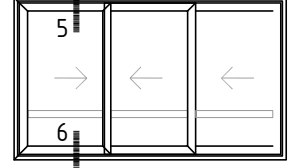
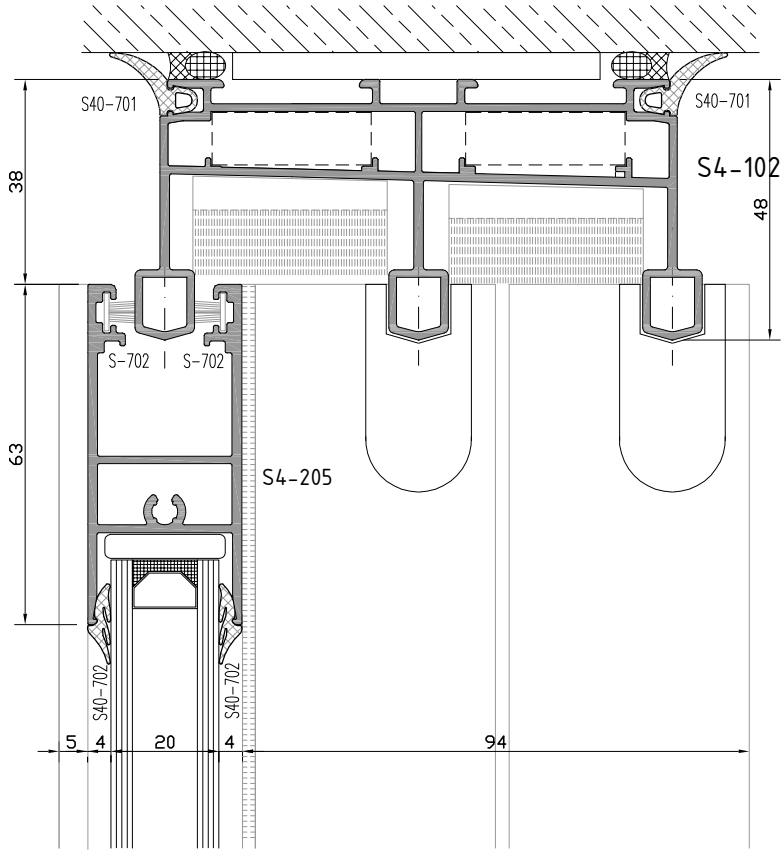

3 raylı sistem detayları
Triple rail system details

5

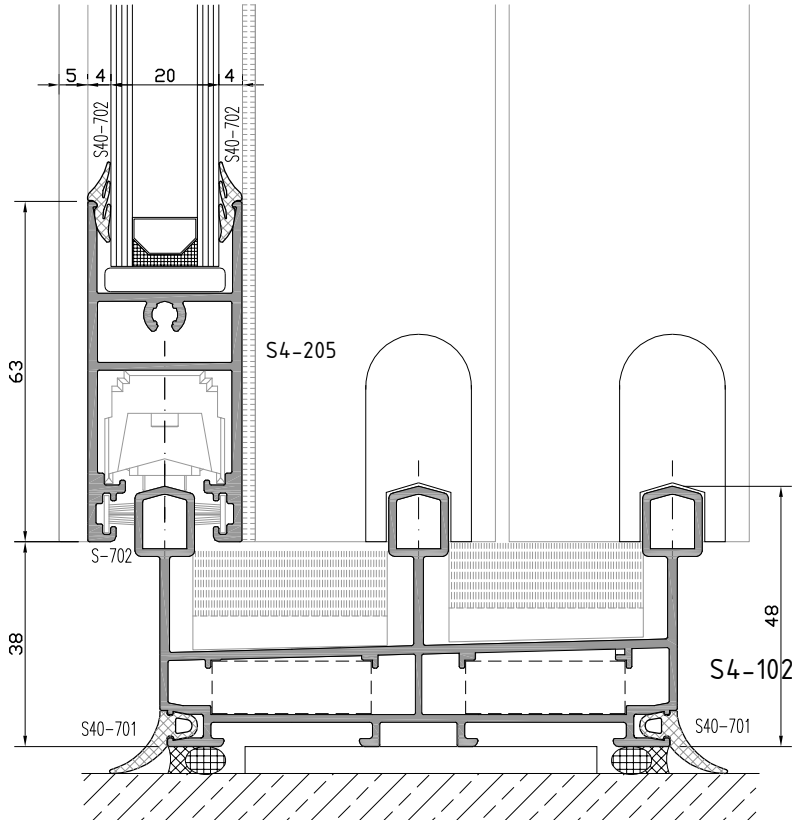

6

S4

S40 YALITIMSIZ SÜRME SERİ

S40 NONINSULATED SLIDING SERIES

ÜST BİTİM - ALT BİTİM DETAYI
TOP EDGE - BOTTOM EDGE DETAIL

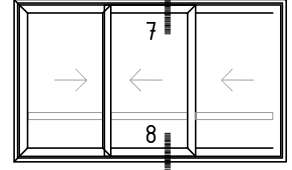
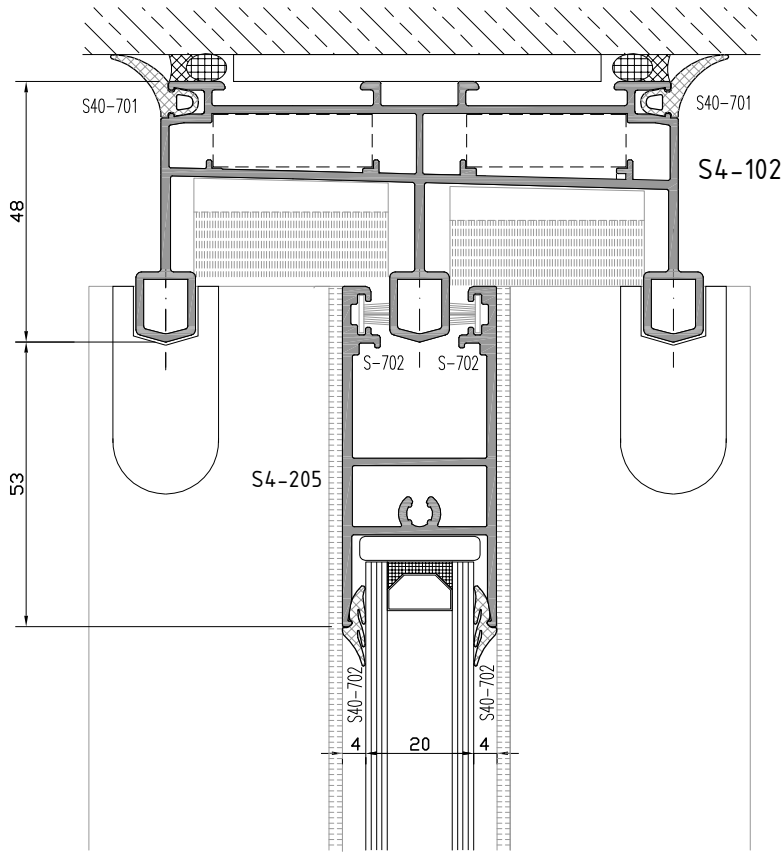

3 raylı sistem detayları
Triple rail system details

7

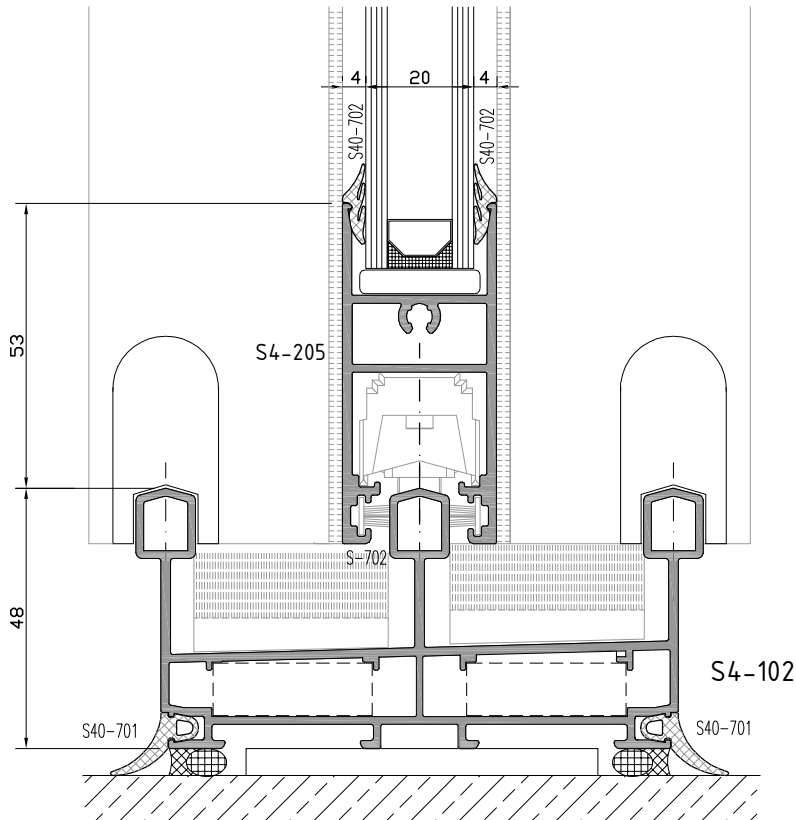

8

S4

S40 YALITIMSIZ SÜRME SERİSİ

S40 NONINSULATED SLIDING SERIES

ÜST-ALT BİTİM - ORTA KAYIT DETAYI
TOP-BOTTOM EDGE - MULLION DETAIL

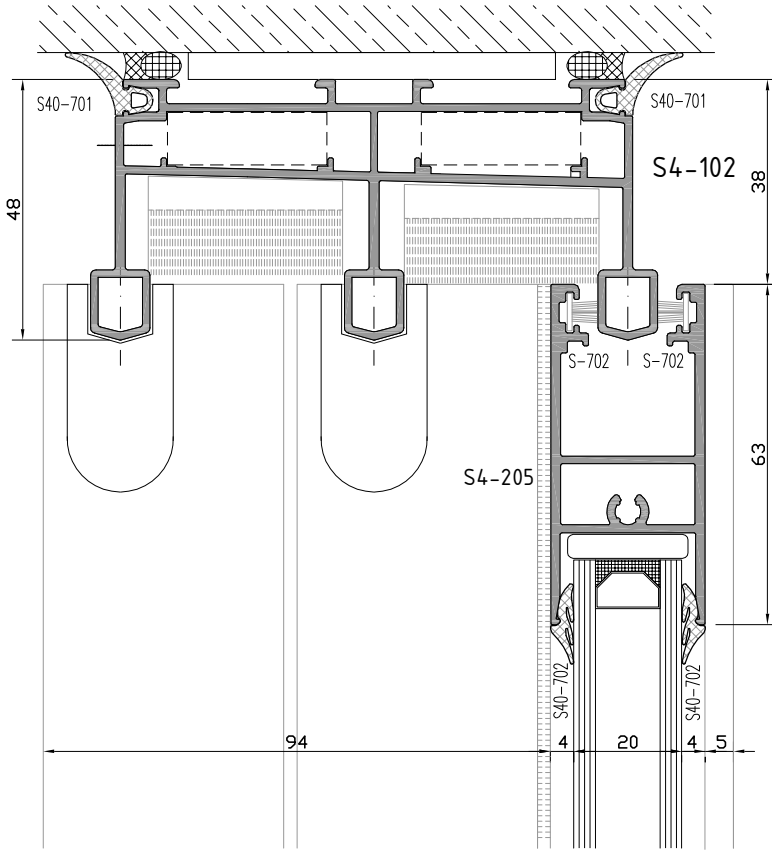

9

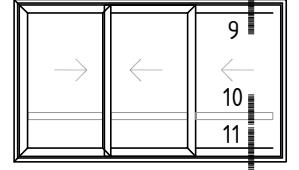

3 raylı sistem detayları
Triple rail system details

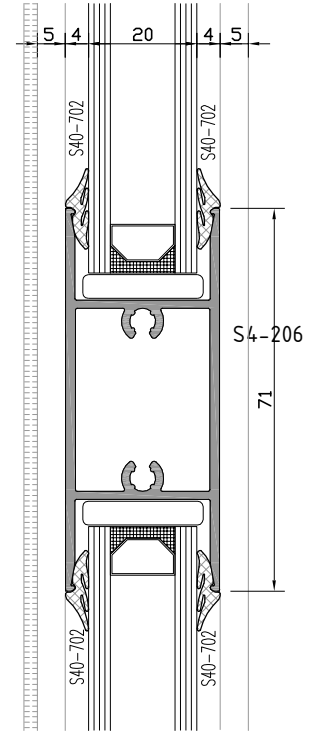

10

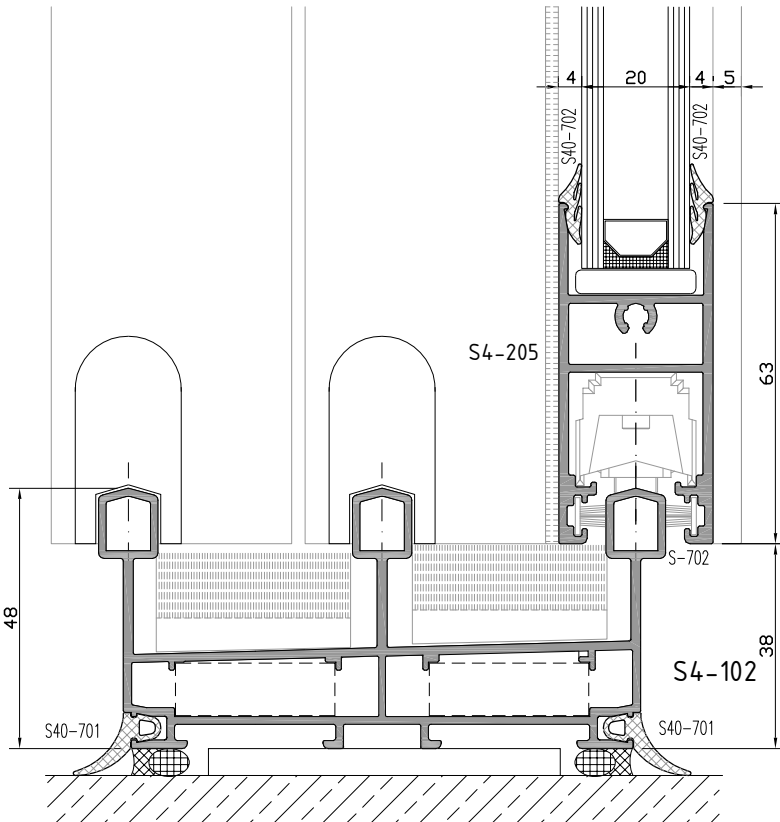

11

not to scale

S4

S40 YALITIMSIZ SÜRME SERİ

S40 NONINSULATED SLIDING SERIES

ÜST BİTİM - ORTA KAYIT DETAYI

TOP EDGE - MULLION DETAIL

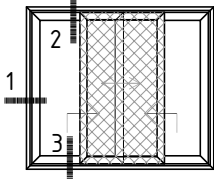

sineklik-damlık detayları
Flyscreen - weatherdrip details

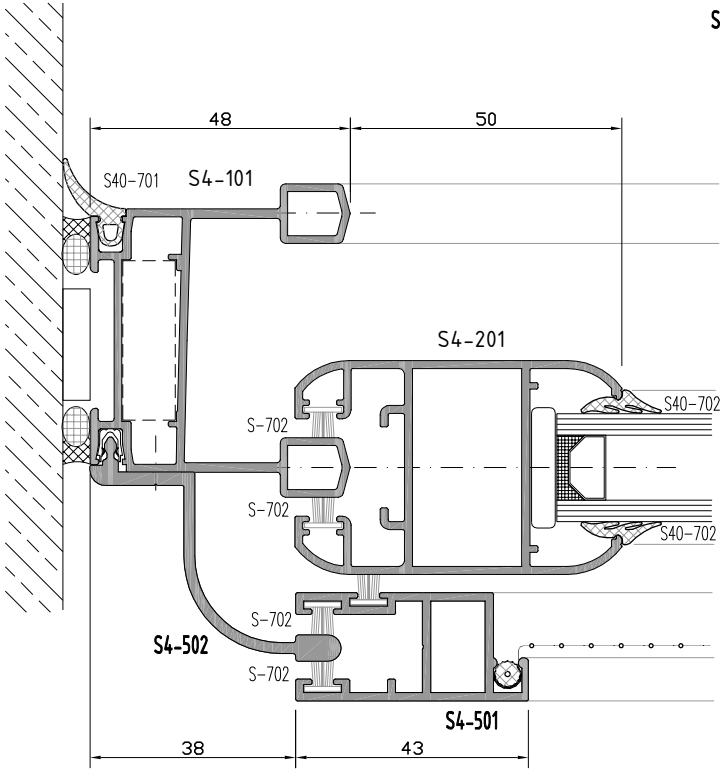

1

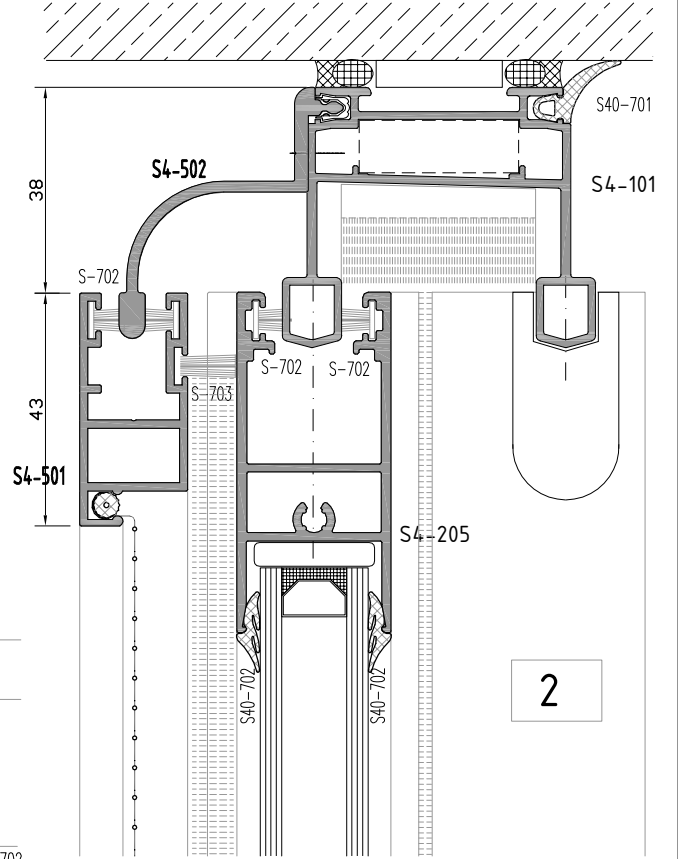

2

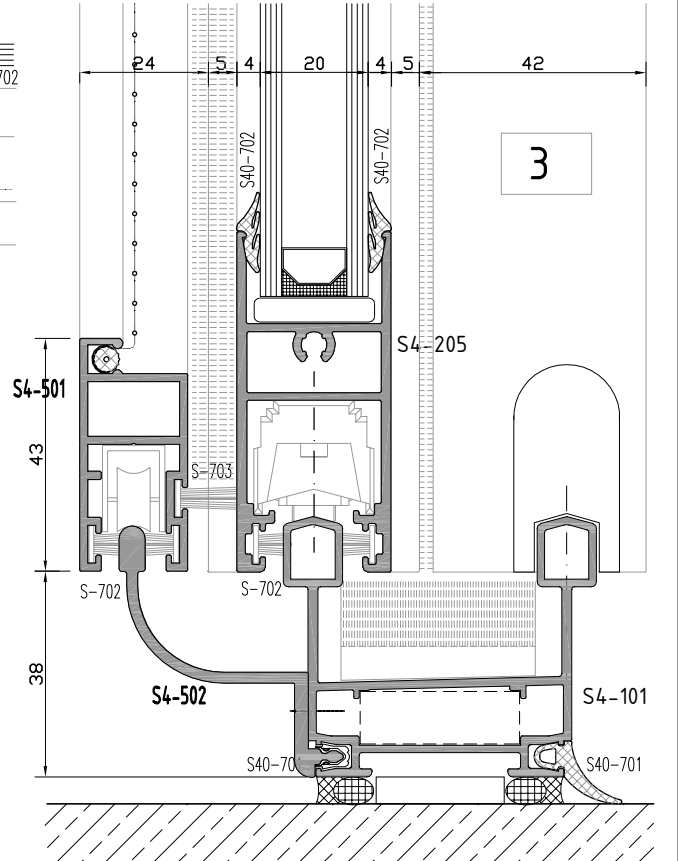

3

not to scale

S4

S40 YALITIMSIZ SÜRME SERİ

S40 NONINSULATED SLIDING SERIES

YAN BİTİM DETAYI

WALL CONNECTION DETAIL

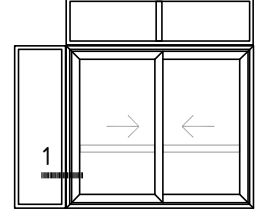

sistem birleşim detayları
System connection details

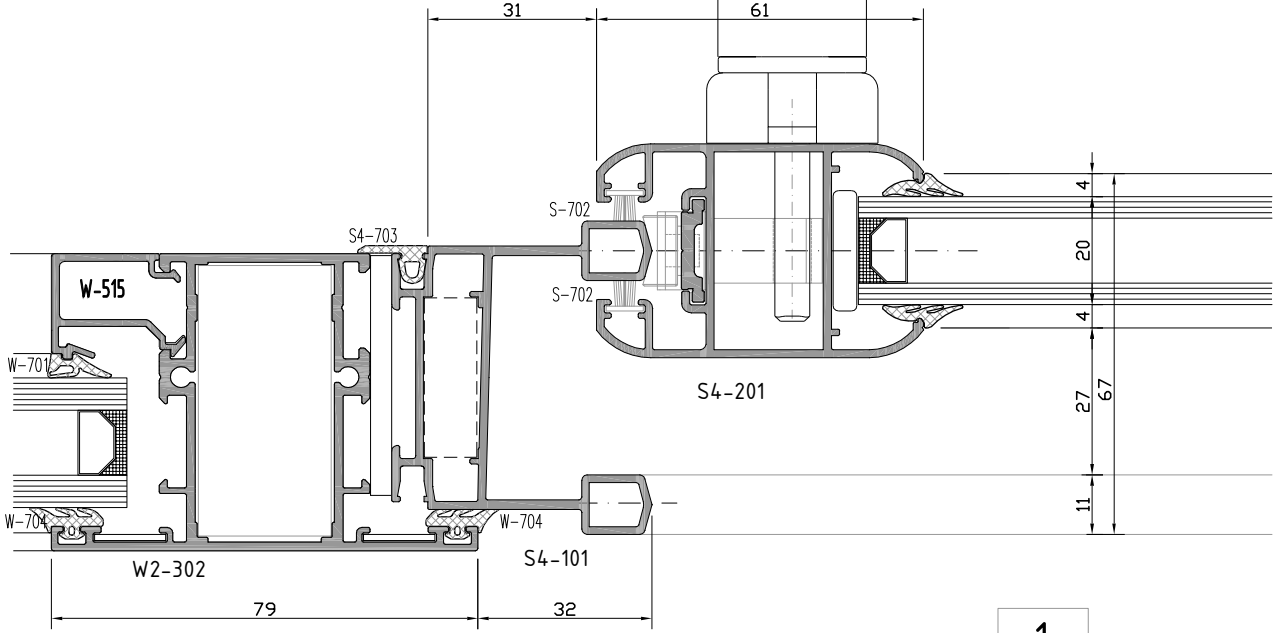

not to scale

S4

S40 YALITIMSIZ SÜRME SERİ

S40 NONINSULATED SLIDING SERIES

İMALAT ŞEMASI

PRODUCTION PLAN

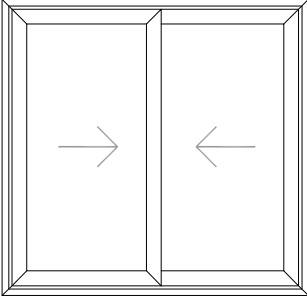

SÜRME SİSTEM
SLIDE SYSTEM

$KX = \frac{L-36}{2}$
$KY = H-76$
$G = B+28$

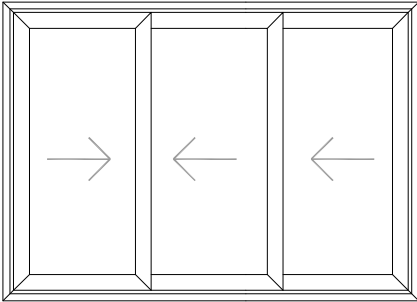
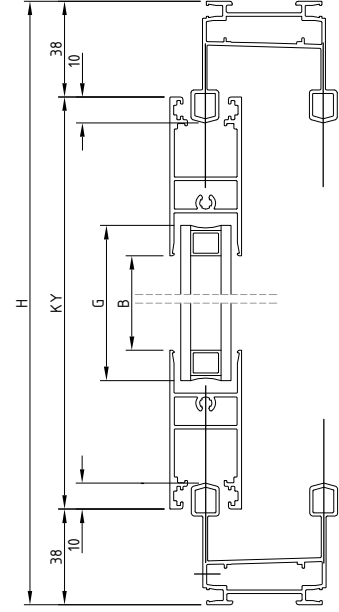
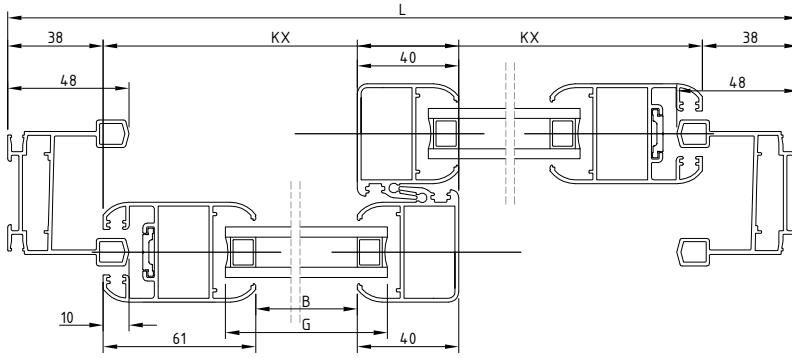

SÜRME SİSTEM
SLIDE SYSTEM

$KX = \frac{L-76}{3}$
$KY = H-76$
$G = B+28$

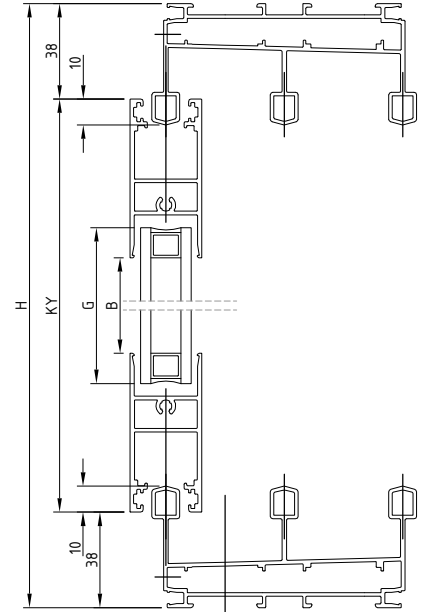
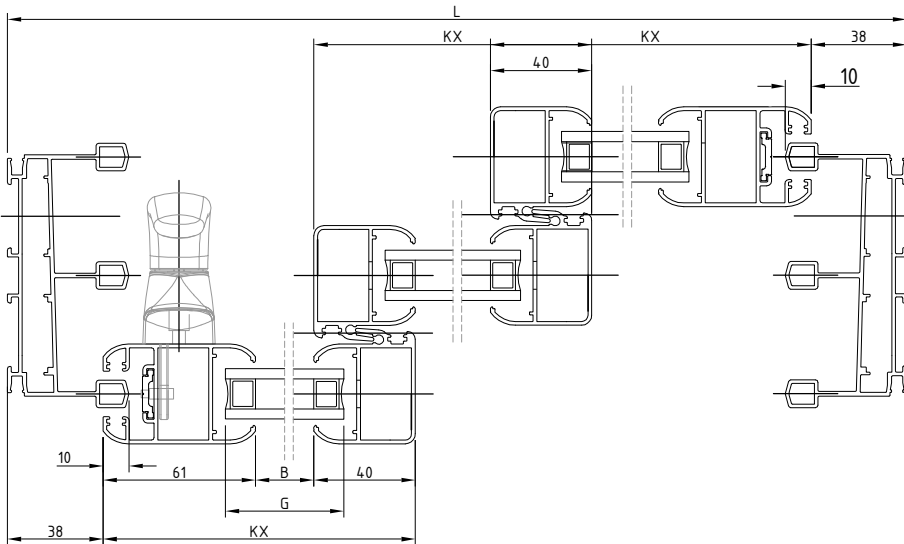

S40 SERİ PROFİLLERİ

S40 PROFILES SERIE

Fıtıl listesi

Gasket list

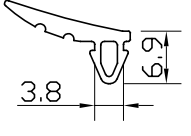
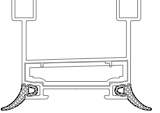
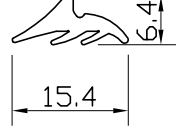
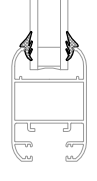
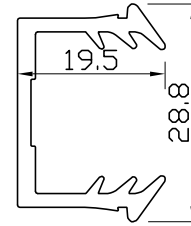
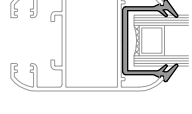
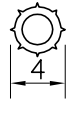
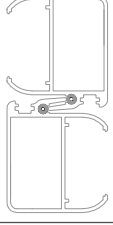
kod code	şekil drawing	tanım description	teorik ağırlık theoretical weight gr / m	paket ağırlığı package weight kg / package	paket metrajı in one package metre / package	kullanım yeri aplication
S40-701		epdm cam dış fıtıl glazing gasket outside (epdm)	56,7 gr/m	15 kg	265 m	
S40-702		epdm cam iç fıtıl glazing gasket inside	54 gr/m	15 kg	277 m	
S40-704		epdm cam iç fıtıl glazing gasket inside	176 gr/m	15 kg	85 m	
S-705		epdm fıtıl epdm gasket	16 gr/m	15 kg	938 m	

S40 YALITIMSIZ SÜRME SERİ
S40 NONINSULATED SLIDING SERIES

AÇILIM MEKANİZMALARI
OPENING MECHANISMS

S40 SÜRME SERİ
S40 SLIDE SYSTEM

Max 80 Kg

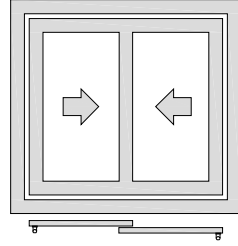

Max 160 Kg

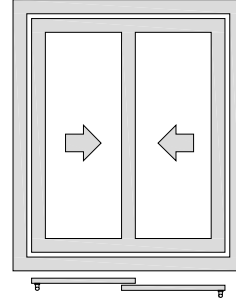

AÇILIM TIPLERİ
OPENING STYLES

2 KANATLI
2 SASHES

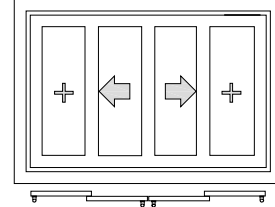
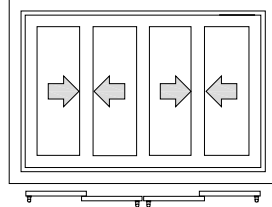
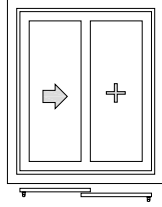
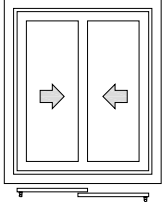

3 KANATLI
3 SASHES

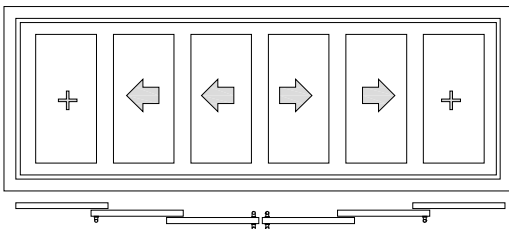
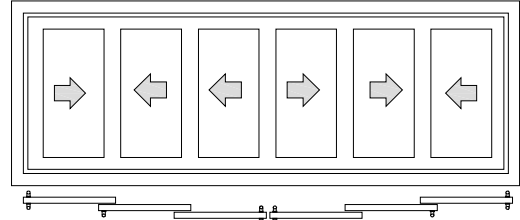
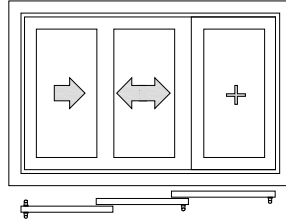
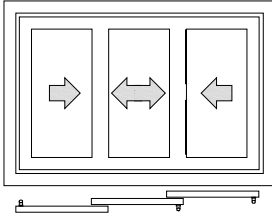

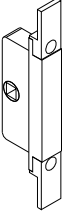
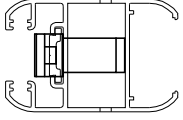
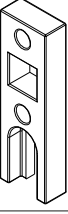
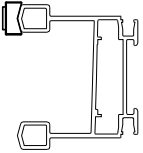
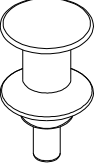
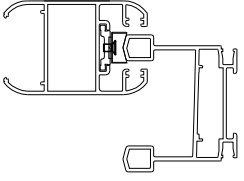
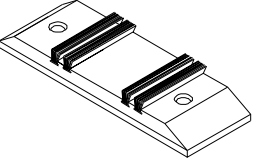
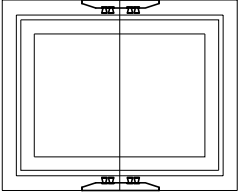
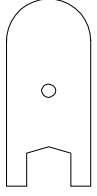
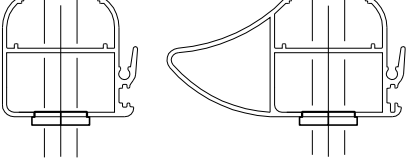
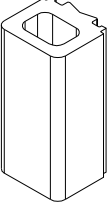
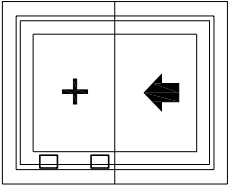
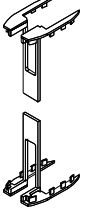
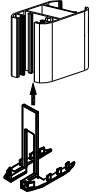

S40 YALITIMSIZ SÜRME SERİ
S40 NONINSULATED SLIDING SERIES

AÇILIM MEKANİZMALARI
OPENING MECHANISMS

kod code	şekil drawing	tanım description	kullanım yeri aplication
S40-900		Çift eksen anahtar Dual-axis key	
S40-901		Pim karşılığı Counterpins	
S40-902		Pim Pin	
S40-903		Kanat birl. izolasyon Central plugs kit for sliding	
S40-904		Kanat kapak Sash Closing Plug	
S40-905		Kanat sabitleme tk. Fixed sash kit	
S40-906		Pvc kapak Pvc cover	

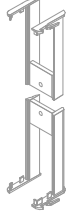
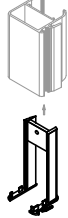
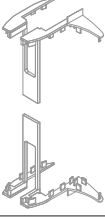
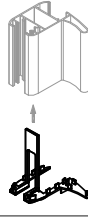
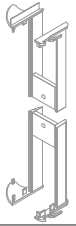
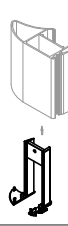

S40 YALITIMSIZ SÜRME SERİ
S40 NONINSULATED SLIDING SERIES

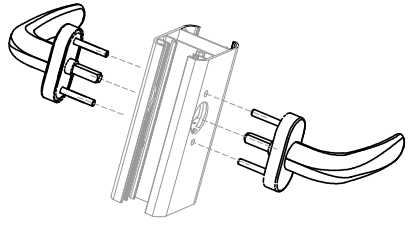
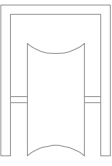
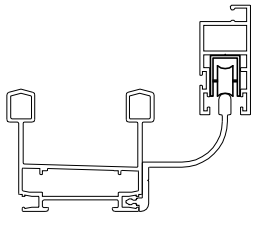
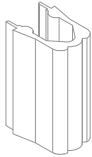
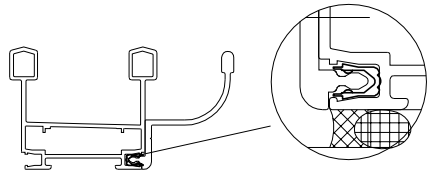
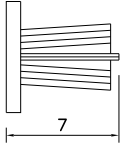
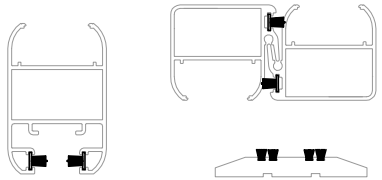
AÇILIM MEKANİZMALARI
OPENING MECHANISMS

kod code	şekil drawing	tanım description	kullanım yeri application
S40-907		Pvc kapak Pvc cover	
S40-908		Pvc kapak Pvc cover	
S40-909		Pvc kapak Pvc cover	
S40-910		Prima eksenel kol Prima handle	
S40-911		Sineklik rulmanı Bearing for flying screen	
S40-912		Adaptör pr. (pvc) Adapter profile (pvc)	
S-702		Kıl fitil 7mm brush 7mm	

S40 YALITIMSIZ SÜRME SERİ
S40 NONINSULATED SLIDING SERIES

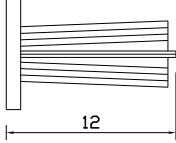
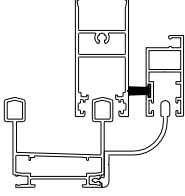
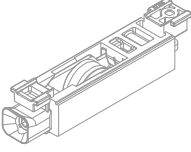
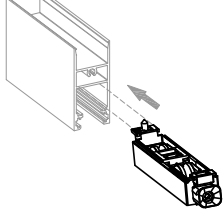
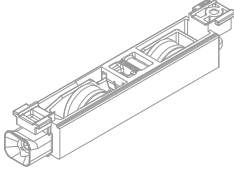
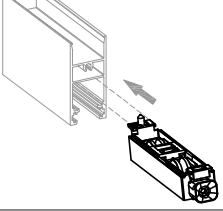
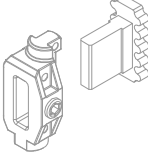
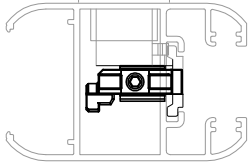
AÇILIM MEKANİZMALARI
OPENING MECHANISMS

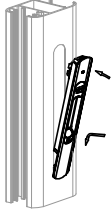
kod code	şekil drawing	tanım description	kullanım yeri application
S-703		Kıl fitil 7mm brush 7mm	
S-801-1		Ayarlı rulman 80kg Carrera 1 adjustable pulley	
S-802-1		Ayarlı rulman 160 kg Carrera 2 adjustable pulley	
S-814		Gömme kol-tij bağl. Embedding handle connection	
S-824		Brio plus havuz kol Brio plus handle	

S40 YALITIMSIZ SÜRME SERİ
S40 NONINSULATED SLIDING SERIES

AÇILIM MEKANİZMALARI
OPENING MECHANISMS

S40-900
Çift eksen anahtar
Dual-axis key

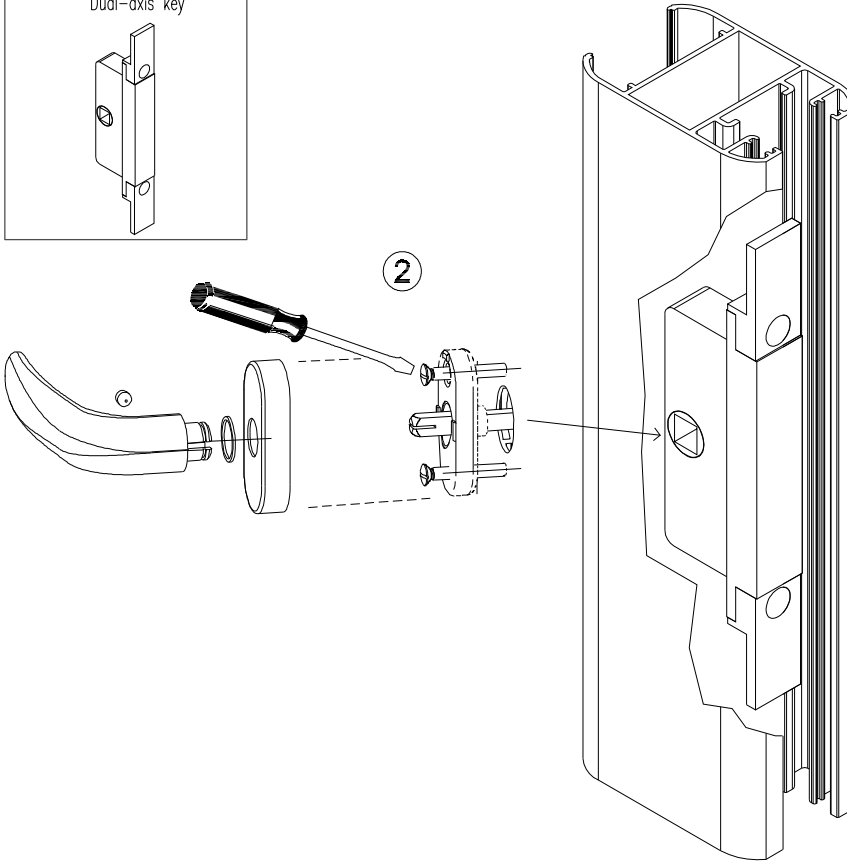
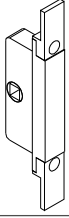

A

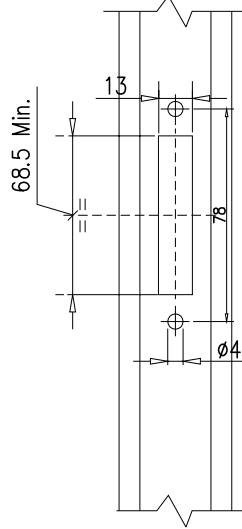
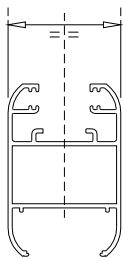
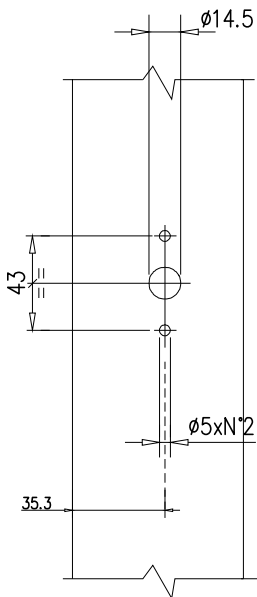
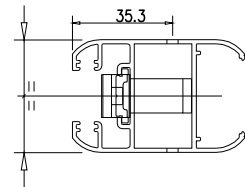

B

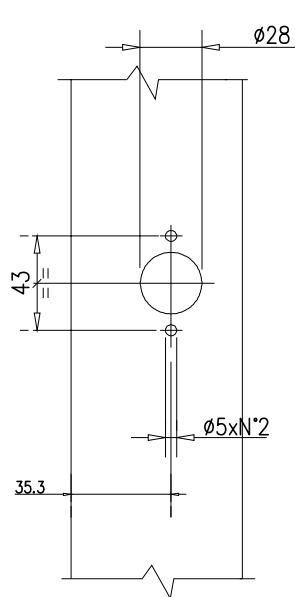
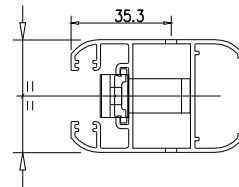

S40 YALITIMSIZ SÜRME SERİ
S40 NONINSULATED SLIDING SERIES

AÇILIM MEKANİZMALARI
OPENING MECHANISMS

S40-901
Pim karşılığı
Counterpins

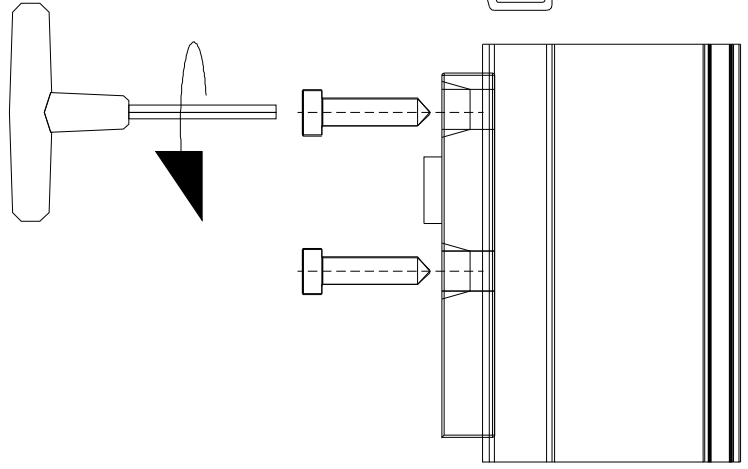
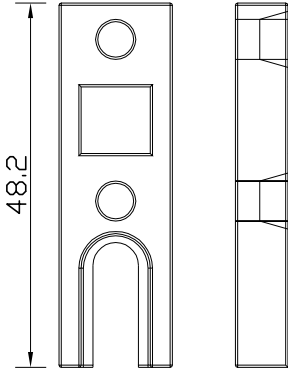
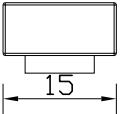
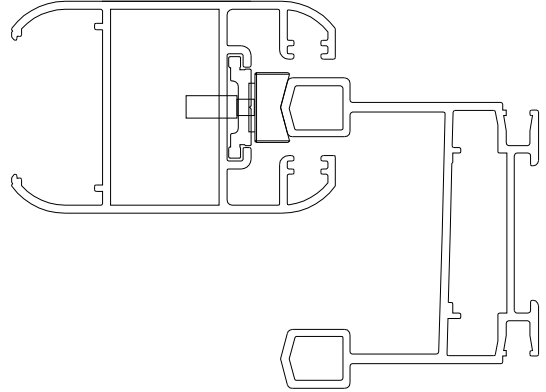
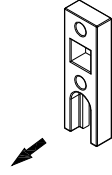
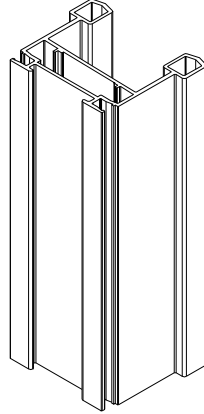
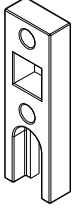

S40-902
Pim
Pin

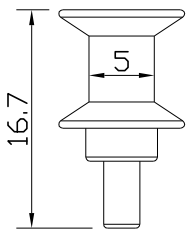
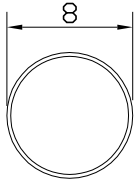
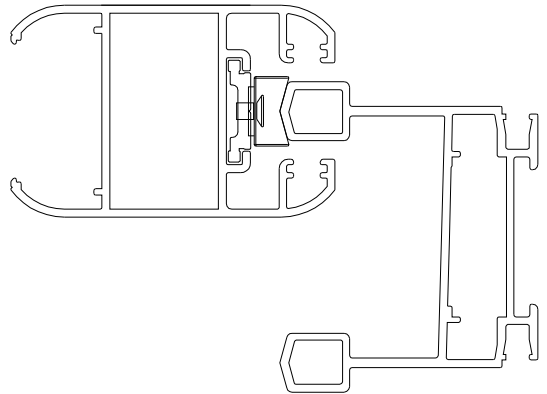
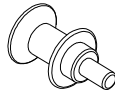
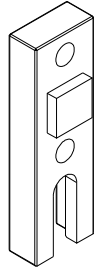
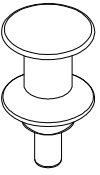

S40 YALITIMSIZ SÜRME SERİ
S40 NONINSULATED SLIDING SERIES

AÇILIM MEKANİZMALARI
OPENING MECHANISMS

S40-903

Sürme kanat birt. izolasyon tk.
Central plugs kit for sliding

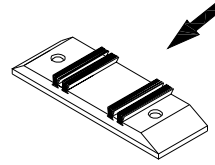
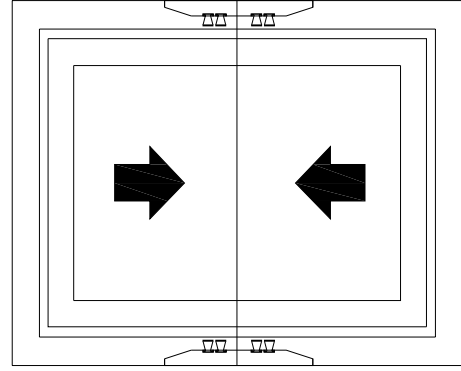
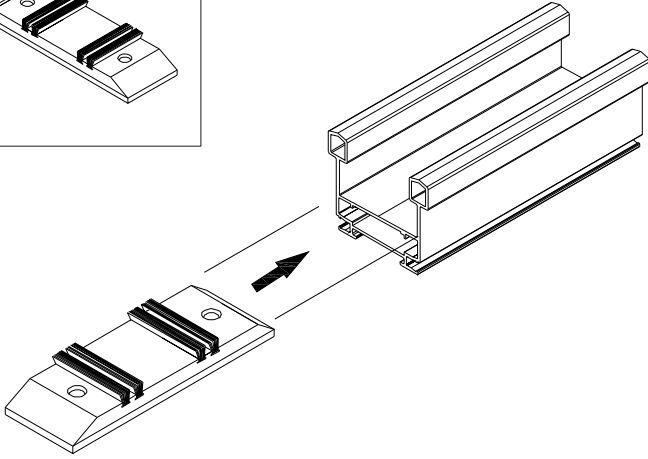
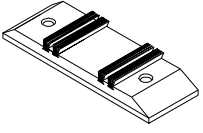

S40-904

Kanat kapak
Sash Closing Plug

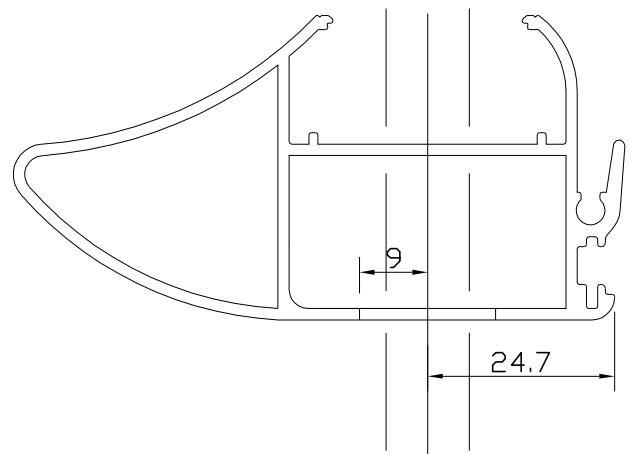
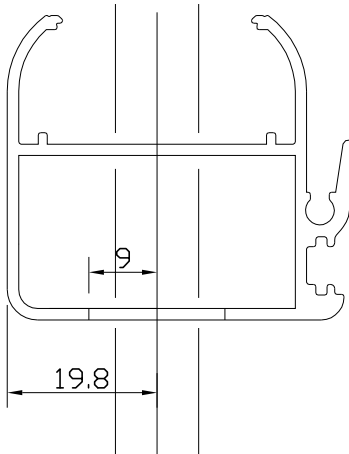
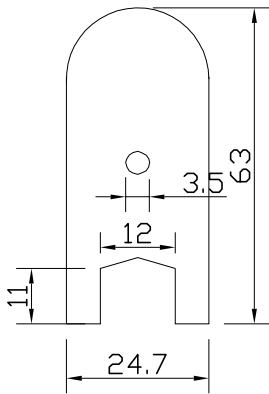
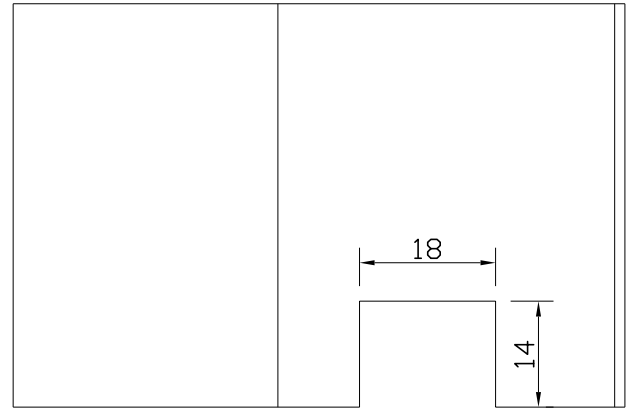
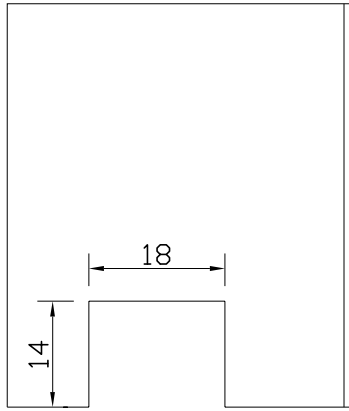
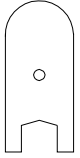

S40 YALITIMSIZ SÜRME SERİ
S40 NONINSULATED SLIDING SERIES

AÇILIM MEKANİZMALARI
OPENING MECHANISMS

S40-905
Kanat sabitleme tk.
Fixed sash kit

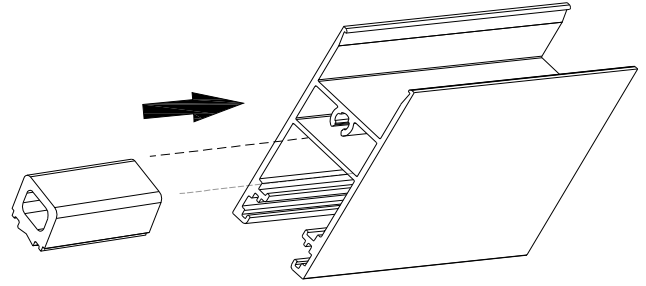
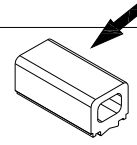
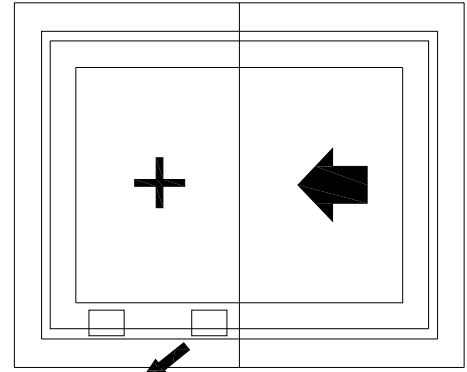
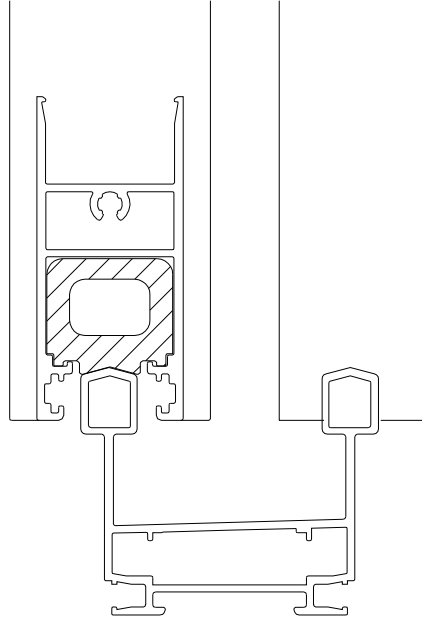
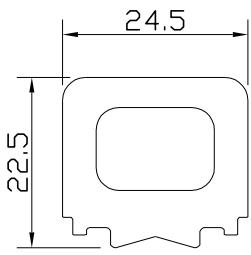
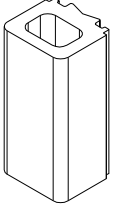

S40-906
Pvc kapak
Pvc cover

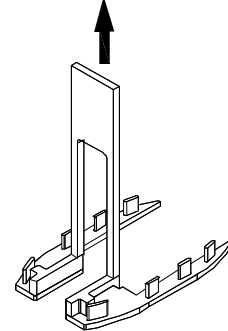
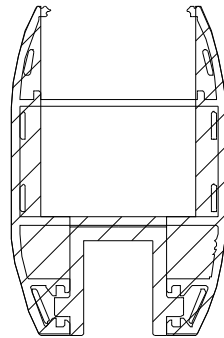
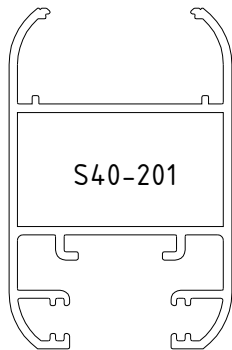
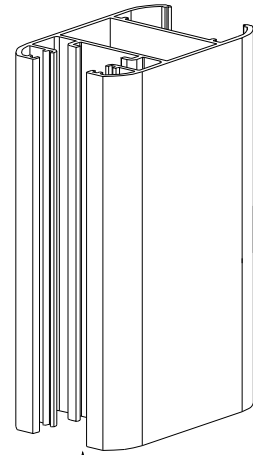
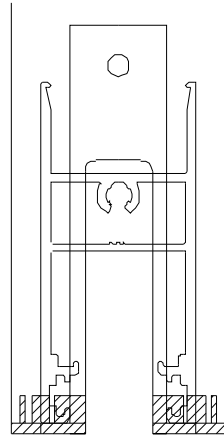
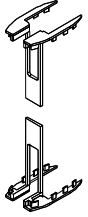

S40 YALITIMSIZ SÜRME SERİ
S40 NONINSULATED SLIDING SERIES

AÇILIM MEKANİZMALARI
OPENING MECHANISMS

S40-907
Pvc kapak
Pvc cover

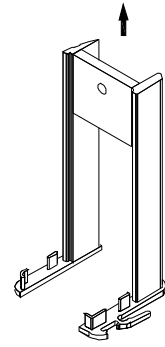
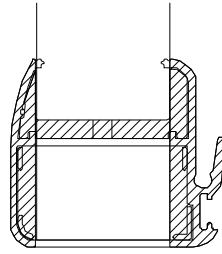
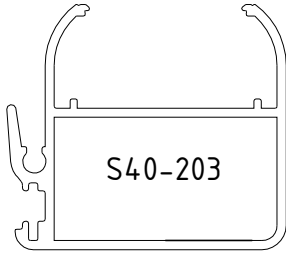
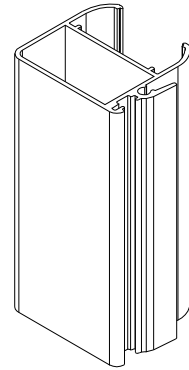
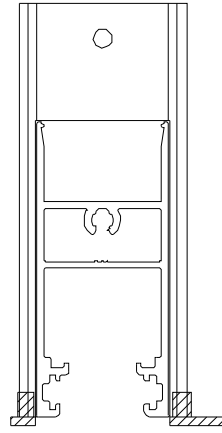
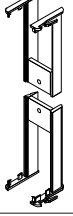

S40-908
Pvc kapak
Pvc cover

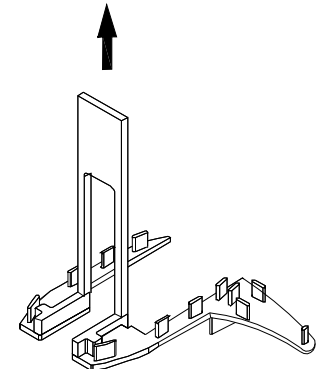
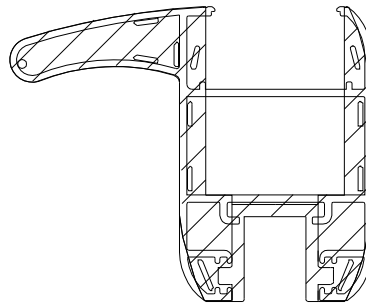
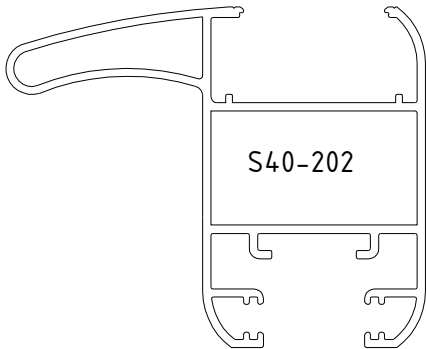
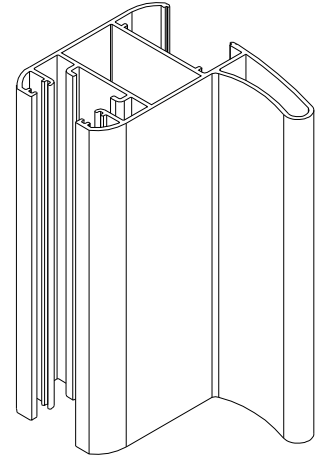
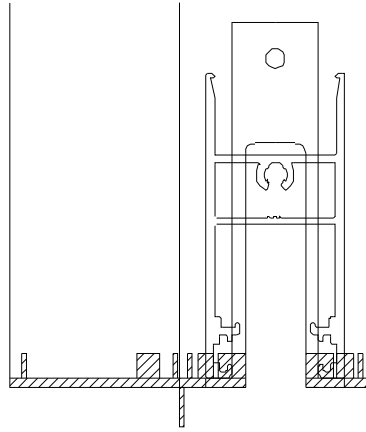
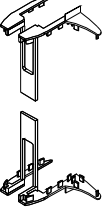

S40 YALITIMSIZ SÜRME SERİ
S40 NONINSULATED SLIDING SERIES

AÇILIM MEKANİZMALARI
OPENING MECHANISMS

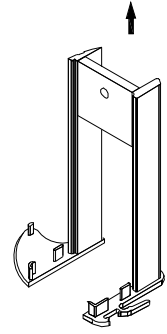
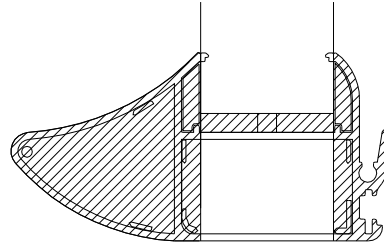
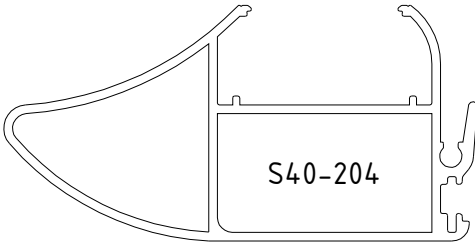
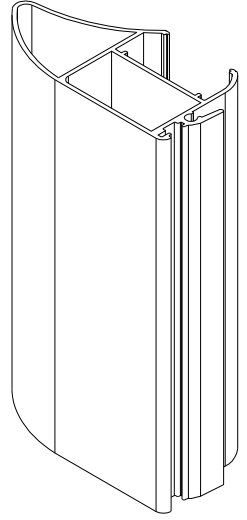
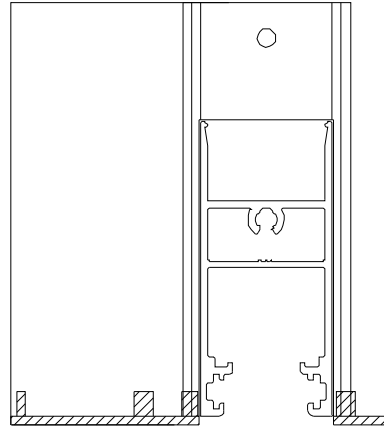
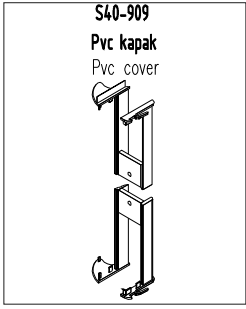

S40 YALITIMSIZ SÜRME SERİ
S40 NONINSULATED SLIDING SERIES

AÇILIM MEKANİZMALARI
OPENING MECHANISMS

S40-910
Prima eksenel kol
Prima handle

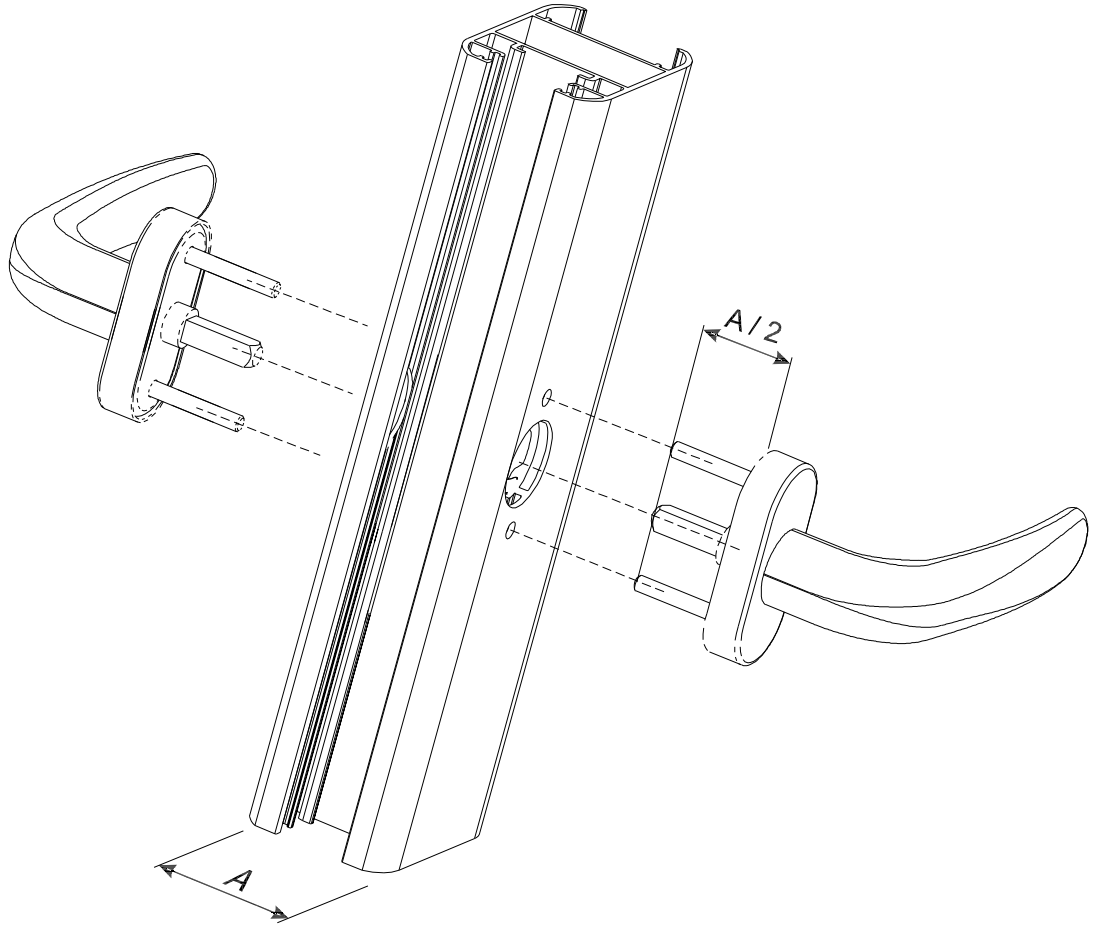

A

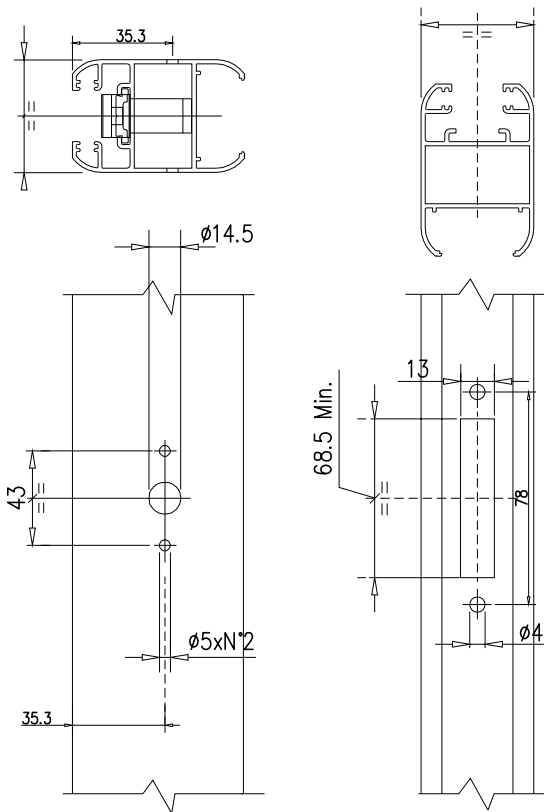

B

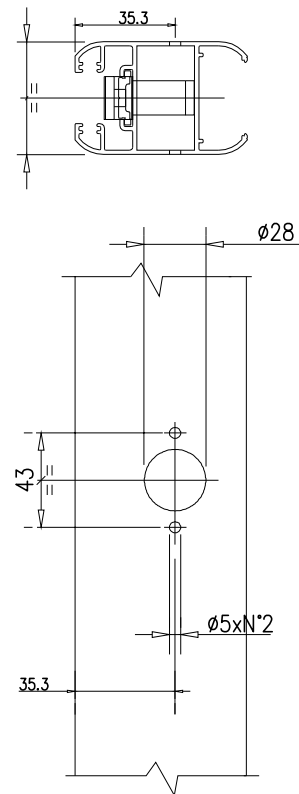

S40 YALITIMSIZ SÜRME SERİ
S40 NONINSULATED SLIDING SERIES

AÇILIM MEKANİZMALARI
OPENING MECHANISMS

S40-911

Sineklik rulmanı
Bearing for flying screen

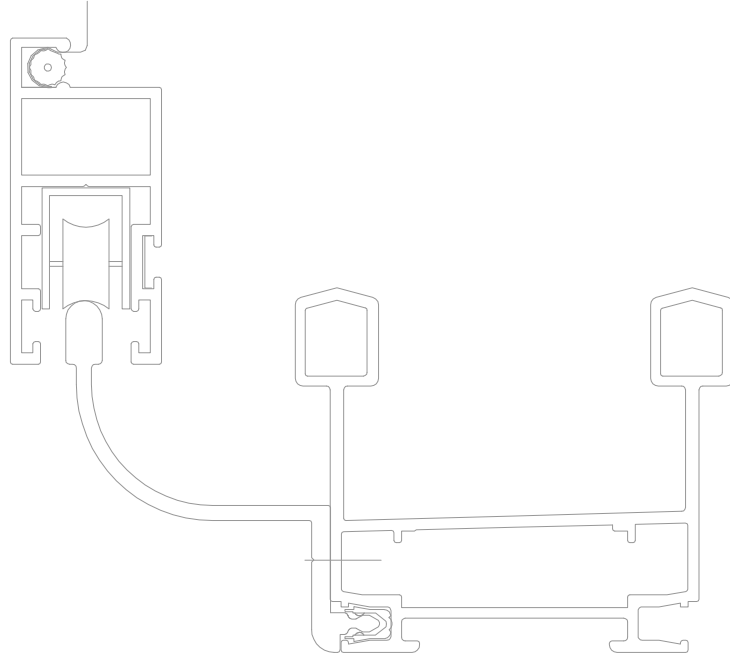
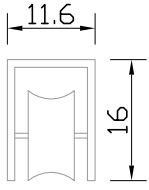
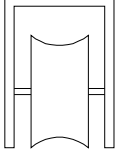

S40-912

Adaptör pr. (pvc)
Adapter profile (pvc)

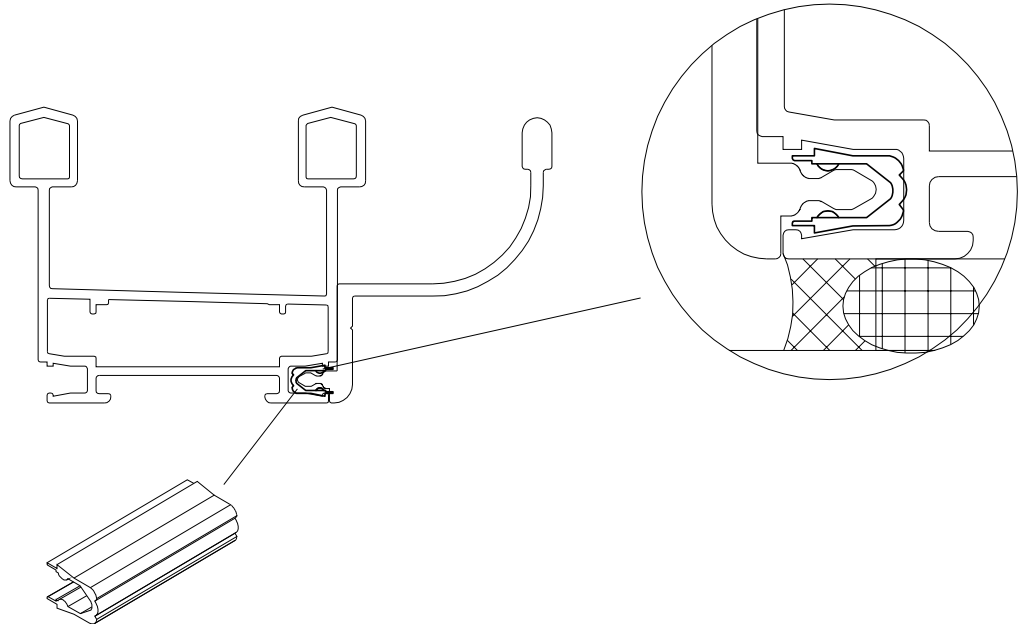
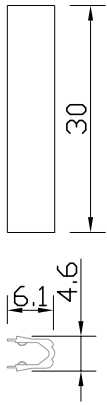
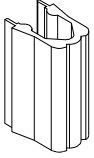

S40 YALITIMSIZ SÜRME SERİ
S40 NONINSULATED SLIDING SERIES

AÇILIM MEKANİZMALARI
OPENING MECHANISMS

S-801-1

Ayarlı rulman 80kg
Carrera 1 adjustable pulley

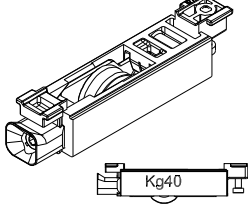

S-802-1

Ayarlı rulman 160 kg
Carrera 2 adjustable pulley

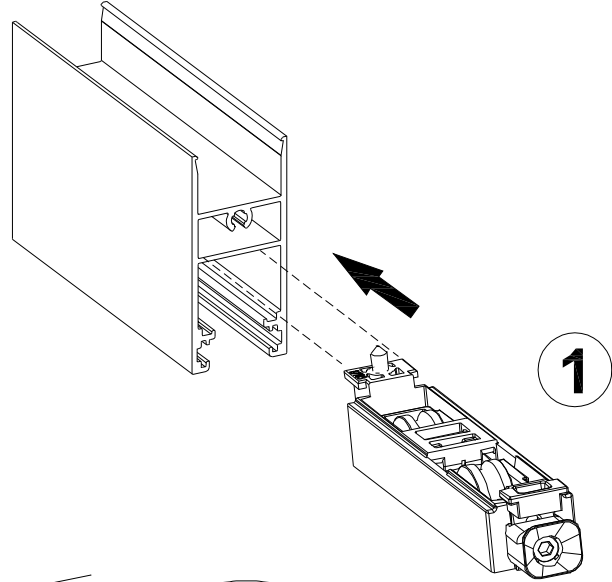
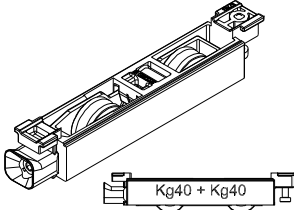

2

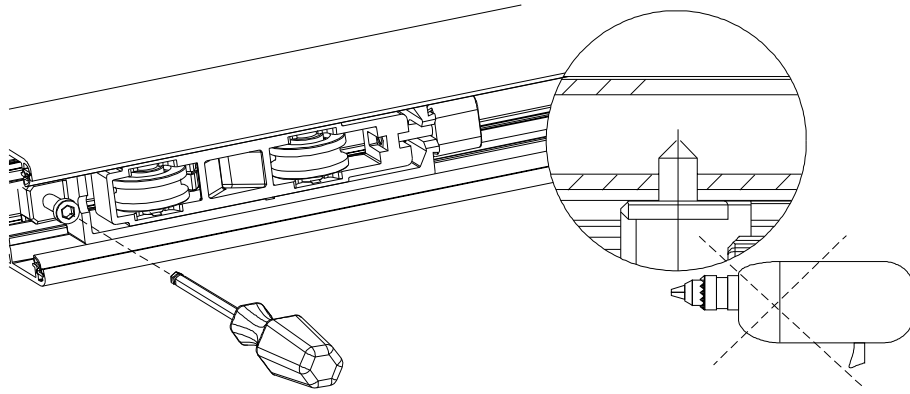

3

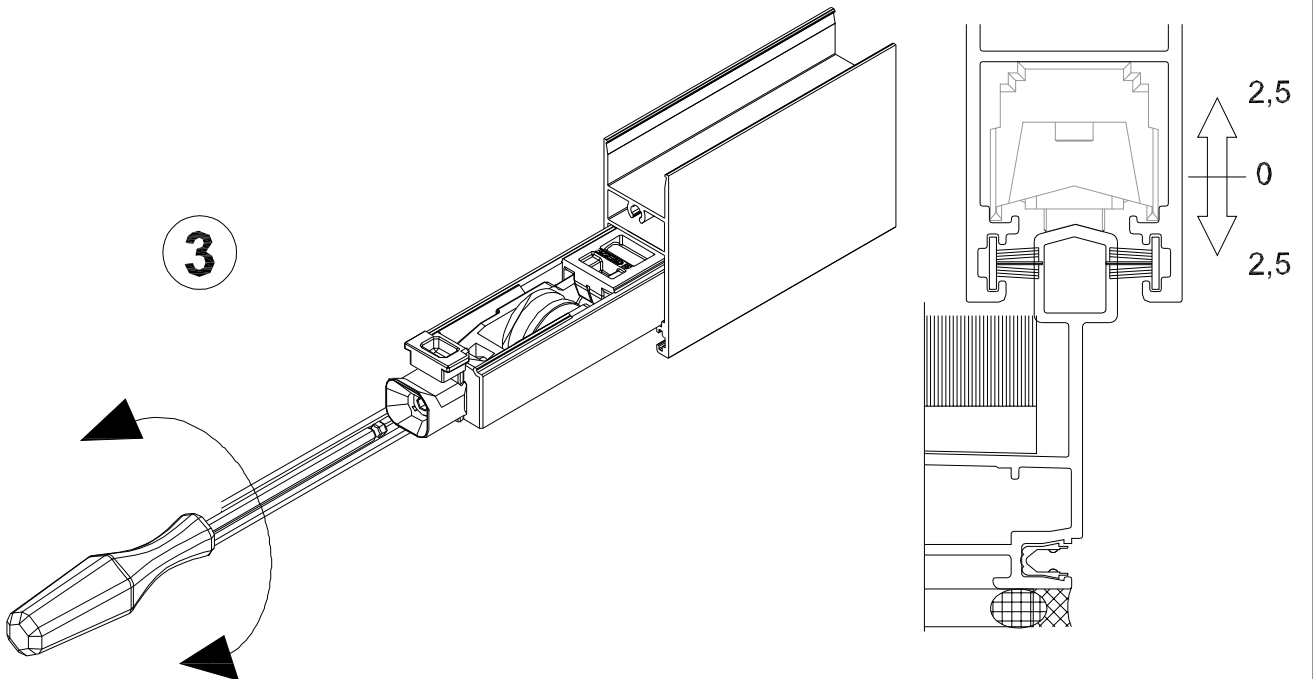

S40 YALITIMSIZ SÜRME SERİ
S40 NONINSULATED SLIDING SERIES

AÇILIM MEKANİZMALARI
OPENING MECHANISMS

S-824

Brio plus havuz kol
Brio plus handle

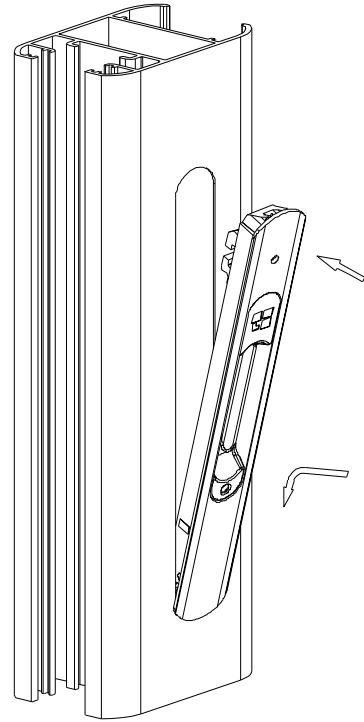
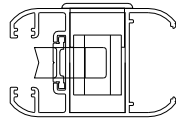
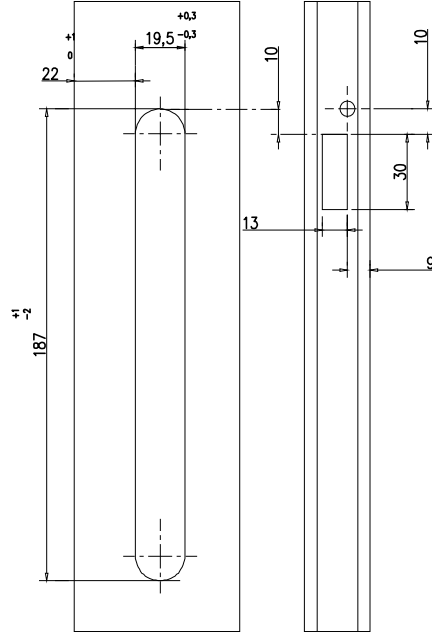

S-814

Gömme kol-tij bağl.
Emmbedding handle connection

