

Yalıtımlı Sürme Serisi Açılım Varyasyonları

Insulated Sliding Serie Opening Variations

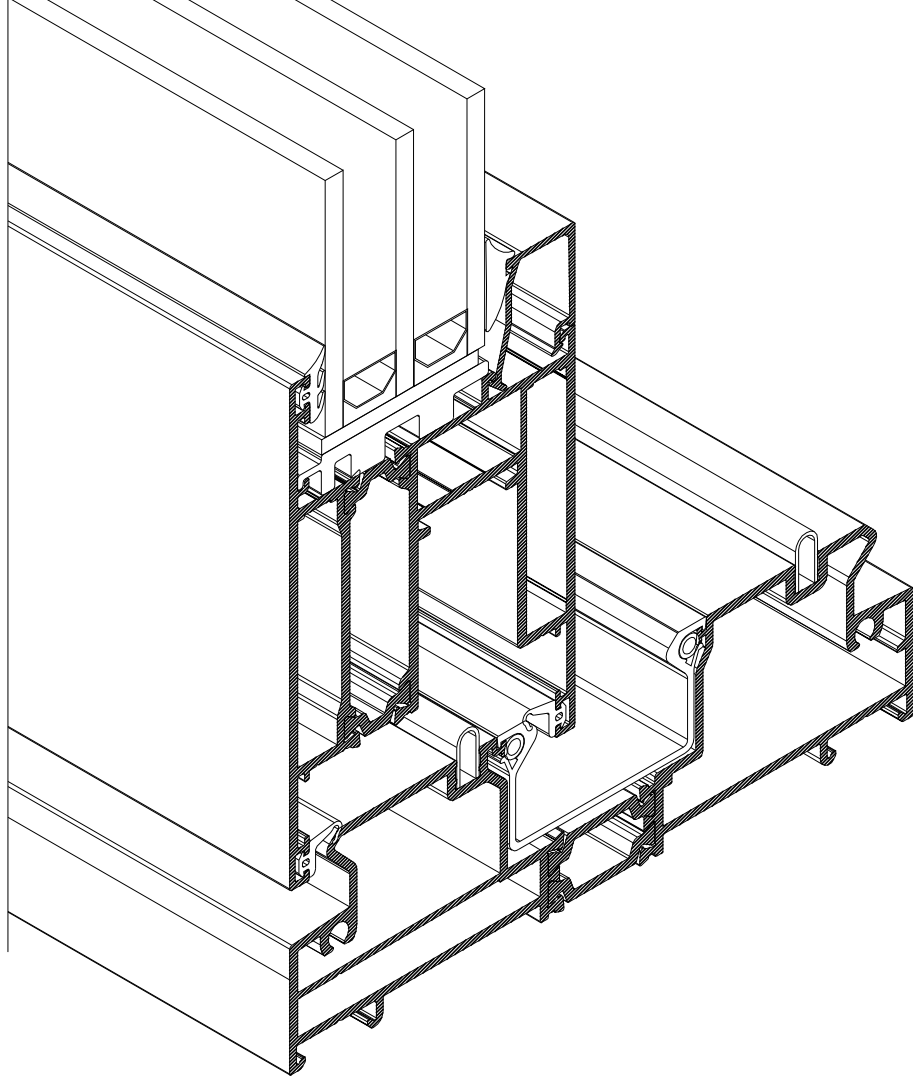
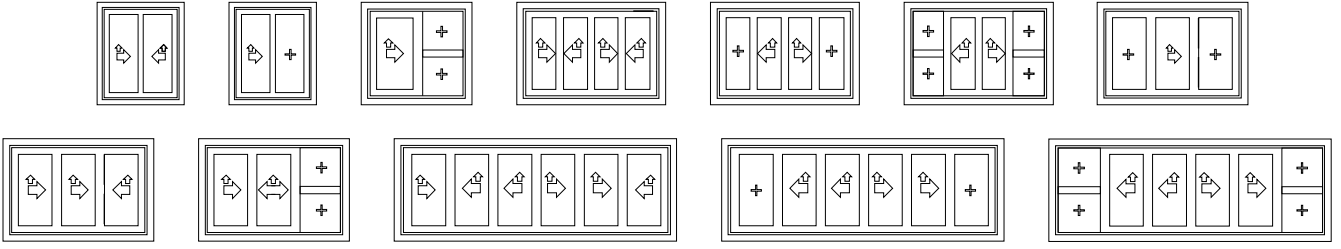

S3

S65 - T Yalıtımlı Sürme Seri

S65 - T Insulated Sliding Serie

Alaşım Özellikleri

Alloy Properties

EN AW 6060 (AlMgSi0,5 F22) EN AW 6063(AlMg0,7Si F22)











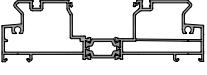

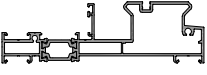

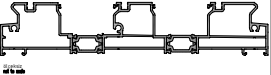
Üretim ve Mekanik Standartları

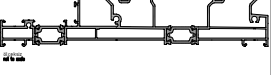
Production and Mecanical Standards

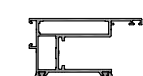
EN 12020-2 - EN 755-9 - EN 755-2

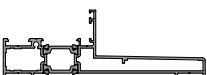
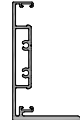

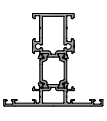
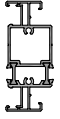
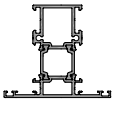

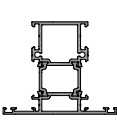
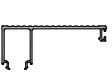
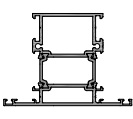



















S3

ÜRÜN TEKNİK ÖZELLİKLERİ
PRODUCT'S TECHNICAL FEATURES

PROFİL KESİTİ PROFILE VIEW	PROFİL NO PROFILE NO	PROFİL AÇIKLAMASI PROFILE DESCRIPTION	gr/m	PROFİL KESİTİ PROFILE VIEW	PROFİL NO PROFILE NO	PROFİL AÇIKLAMASI PROFILE DESCRIPTION	gr/m
	S3-101 (140.5 - 42.6)	KASA PROFİLİ FRAME	PVC 2532		S3-504 (72.6 - 10.6)	ADAPTÖR PROFİLİ ADAPTER PROFILE	705
			POLYAMID 2517				
	S3-102 (140.5 - 42.6)	KASA PROFİLİ FRAME	PVC 2336		S3-505 (29.1 - 23.6)	ADAPTÖR PROFİLİ ADAPTER PROFILE	223
			POLYAMID 2322				
	S3-103 (216.6 - 41.6)	KASA PROFİLİ FRAME	PVC 3854		S3-506 (30.6 - 12)	ADAPTÖR PROFİLİ ADAPTER PROFILE	269
			POLYAMID 3825				
	S3-104 (216.6 - 41.6)	KASA PROFİLİ FRAME	PVC 3828		S3-509 (52.5 - 20.8)	ADAPTÖR PROFİLİ ADAPTER PROFILE	614
			POLYAMID 3798				
	S3-201 (98.5 - 64.2)	KANAT PROFİLİ CASEMENT PROFILE	PVC 2402		S3-510 (22 - 12)	ADAPTÖR PROFİLİ ADAPTER PROFILE	251
			POLYAMID 2391				
	S3-507 (140.4 - 49)	ADAPTÖR PROFİLİ ADAPTER PROFILE	PVC 2009		S3-511 (47 - 82)	ADAPTÖR PROFİLİ ADAPTER PROFILE	1300
			POLYAMID 1995				
  İşaretti profil için satış temsilcinizden bilgi alınız.	S3-508 (140.4 - 16.6)	ADAPTÖR PROFİLİ ADAPTER PROFILE	PVC 1497		W6-301 (69 - 29)	ORTA KAYIT PROFİLİ TRANSOM PROFILE	PVC 1595
			POLYAMID 1482				POLYAMID 1581
	S3-501 (76.2 - 32.9)	ADAPTÖR PROFİLİ ADAPTER PROFILE	PVC 1388		W6-308 (74 - 34)	ORTA KAYIT PROFİLİ TRANSOM PROFILE	PVC 1704
			POLYAMID 1379				POLYAMID 1689
	S3-502 (72.2 - 42)	ADAPTÖR PROFİLİ ADAPTER PROFILE	570		W6-302 (79 - 39)	ORTA KAYIT PROFİLİ TRANSOM PROFILE	PVC 1812
							POLYAMID 1798
	S3-503 (76.2 - 30.15)	ADAPTÖR PROFİLİ ADAPTER PROFILE	641		W6-303 (89 - 49)	ORTA KAYIT PROFİLİ TRANSOM PROFILE	PVC 2029
							POLYAMID 2014

Profil değerleri teoriktir. Ağırlık olarak testimde yapılan tartım geçerlidir.
Profil imalatları TS EN 12020-2 ve TS EN 755-9 toleransı,
Moment değerleri EN 14024'e göre hesaplanmıştır.

Profile values are theoretical pre-shipment weight will be valid.
The tolerances of Profile manufacturing are calculated according to EN 12020-2
and TS EN 755-9; moment values are calculated according to EN 14024.

PROFİL KESİTİ PROFILE VIEW	PROFİL NO PROFILE NO	PROFİL AÇIKLAMASI PROFILE DESCRIPTION	gr/m	PROFİL KESİTİ PROFILE VIEW	PROFİL NO PROFILE NO	PROFİL AÇIKLAMASI PROFILE DESCRIPTION	gr/m
	W-511 (3.5 - 24.8)	CAM ÇİTASI GLASS BEAM	189	  İşaretti profil için satış temsilcinizden bilgi alınız.	W-512-a (7.5 - 24.8)	CAM ÇİTASI GLASS BEAM	228
	W-512 (7.5 - 24.8)	CAM ÇİTASI GLASS BEAM	220		W-513-a (11.5 - 24.8)	CAM ÇİTASI GLASS BEAM	218
	W-513 (11.5 - 24.8)	CAM ÇİTASI GLASS BEAM	232		W-514-a (15.5 - 24.8)	CAM ÇİTASI GLASS BEAM	231
	W-514 (15.5 - 24.8)	CAM ÇİTASI GLASS BEAM	254		W-515-a (19.5 - 24.8)	CAM ÇİTASI GLASS BEAM	244
	W-515 (19.5 - 24.8)	CAM ÇİTASI GLASS BEAM	274		W-516-a (23.5 - 24.8)	CAM ÇİTASI GLASS BEAM	273
	W-516 (23.5 - 24.8)	CAM ÇİTASI GLASS BEAM	287		W-517-a (27.5 - 24.8)	CAM ÇİTASI GLASS BEAM	286
	W-517 (27.5 - 24.8)	CAM ÇİTASI GLASS BEAM	300		W-518-a (31.5 - 24.8)	CAM ÇİTASI GLASS BEAM	299
	W-518 (31.5 - 24.8)	CAM ÇİTASI GLASS BEAM	318		W-519-a (35.5 - 24.8)	CAM ÇİTASI GLASS BEAM	319
	W-519 (35.5 - 24.8)	CAM ÇİTASI GLASS BEAM	337		W-520-a (39.5 - 24.8)	CAM ÇİTASI GLASS BEAM	332
	W-520 (39.5 - 24.8)	CAM ÇİTASI GLASS BEAM	352		W-521-a (43.5 - 24.8)	CAM ÇİTASI GLASS BEAM	346
	W-521 (43.5 - 24.8)	CAM ÇİTASI GLASS BEAM	367		W-522-a (29.5 - 24.8)	CAM ÇİTASI GLASS BEAM	281
	W-511-a (3.5 - 24.8)	CAM ÇİTASI GLASS BEAM	195		W-522-a (29.5 - 24.8)	CAM ÇİTASI GLASS BEAM	281







 İşaretti profil için satış temsilcinizden bilgi alınız.

Profil değerleri teoriktir. Ağırlık olarak testimde yapılan tartım geçerlidir.
Profil imalatları TS EN 12020-2 ve TS EN 755-9 toleransı,
Moment değerleri EN 14024'e göre hesaplanmıştır.

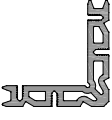
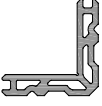
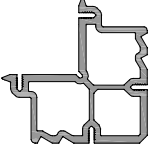
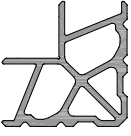
Profile values are theoretical pre-shipment weight will be valid.
The tolerances of Profile manufacturing are calculated according to EN 12020-2
and TS EN 755-9; moment values are calculated according to EN 14024.

S3

ÜRÜN TEKNİK ÖZELLİKLERİ
PRODUCT'S TECHNICAL FEATURES

PROFİL KESİTİ PROFILE VIEW	PROFİL NO PROFILE NO	PROFİL AÇIKLAMASI PROFILE DESCRIPTION	gr/m	PROFİL KESİTİ PROFILE VIEW	PROFİL NO PROFILE NO	PROFİL AÇIKLAMASI PROFILE DESCRIPTION	gr/m
	W-601 (74 - 74) 14.6mm	KÖŞE BİRLEŞTİRME CORNER CLEATS	3428				
	W-611 (67 - 67) 14.6mm	KÖŞE BİRLEŞTİRME CORNER CLEATS	3044				
	W-604 (101 - 47.6) 47.6mm	KÖŞE BİRLEŞTİRME CORNER CLEATS	5539				
	W-614 (87 - 87) 47.6mm	KÖŞE BİRLEŞTİRME CORNER CLEATS	5325				
	SC0308 (55 - 55)	KÖŞE BİRLEŞTİRME CORNER CLEATS	2313				
	SC0309 (55 - 55)	KÖŞE BİRLEŞTİRME CORNER CLEATS	1573				
	W-606	ORTA KAYIT BİRLEŞTİRME CORNER CLEATS FOR TRANSOM	482				
	W-607 (8.2 - 36.8)	ORTA KAYIT BİRLEŞTİRME CORNER CLEATS FOR TRANSOM	431				
	W-608	ORTA KAYIT BİRLEŞTİRME CORNER CLEATS FOR TRANSOM	583				
	S3-601 (38.4 - 17.6)	ORTA KAYIT BİRLEŞTİRME CORNER CLEATS FOR TRANSOM	545				

Profil değerleri teoriktir. Ağırlık olarak testimde yapılan tartım geçerlidir.
Profil imalatları TS EN 12020-2 ve TS EN 755-9 toleransı,
Moment değerleri EN 14024'e göre hesaplanmıştır.

Profile values are theoretical pre-shipment weight will be valid.
The tolerances of Profile manufacturing are calculated according to EN 12020-2
and TS EN 755-9; moment values are calculated according to EN 14024.

S3
S65-T YALITIMLI SÜRME SERİ
S65 -T INSULATED SLIDING SERIES

ÜRÜN TEKNİK ÖZELLİKLERİ
PRODUCT'S TECHNICAL FEATURES

Profil No: S3-101

Ağırlık PVC : 2532 gr/m	lx : 138,54 cm ⁴
Ağırlık POLY: 2517 gr/m	ly : 16,34 cm ⁴

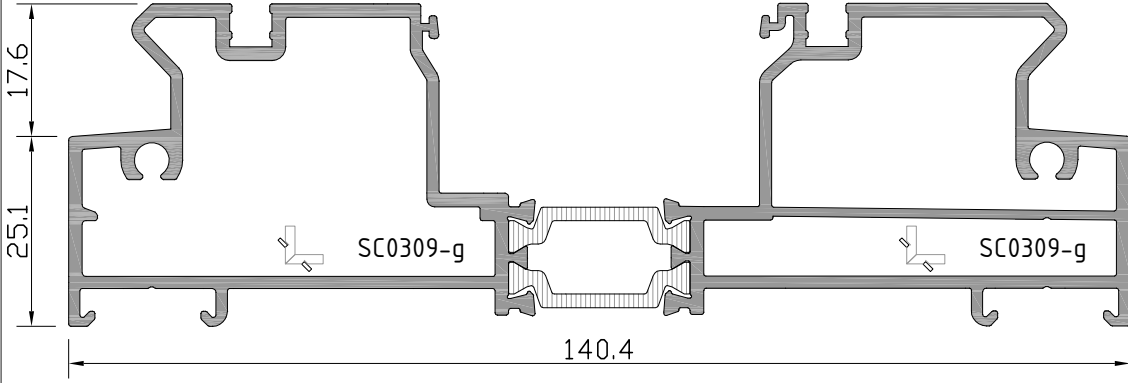

Profil No: S3-102

Ağırlık PVC : 2336 gr/m	lx : 119,45 cm ⁴
Ağırlık POLY: 2322 gr/m	ly : 12,38 cm ⁴

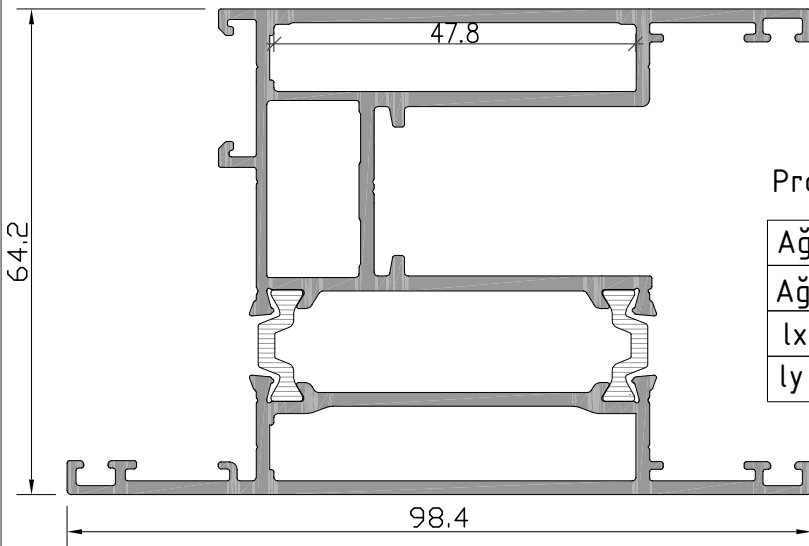
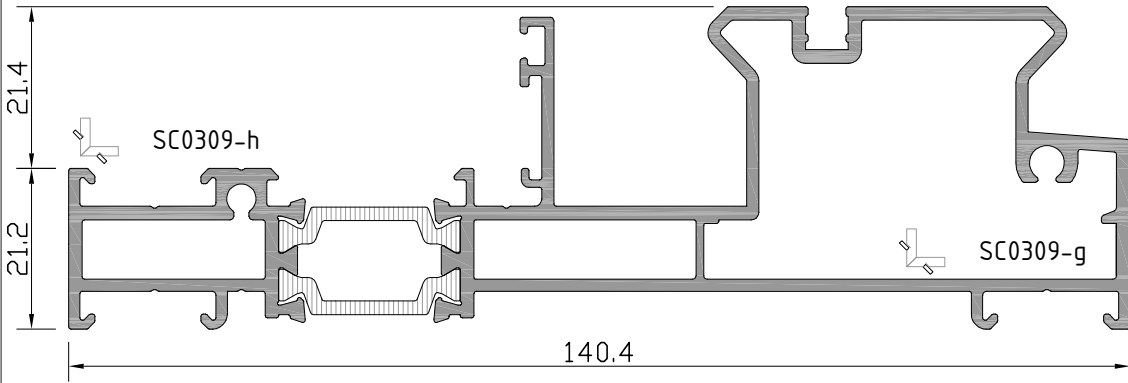

Profil No: S3-201

Ağırlık PVC : 2402 gr/m	lx : 36,35 cm ⁴
Ağırlık POLY: 2391 gr/m	ly : 43,32 cm ⁴

-  W-614-o
-  S3-601-a
-  SC0308-f
-  W-614-o

S3
S65-T YALITIMLI SÜRME SERİ
S65 -T INSULATED SLIDING SERIES

ÜRÜN TEKNİK ÖZELLİKLERİ
PRODUCT'S TECHNICAL FEATURES

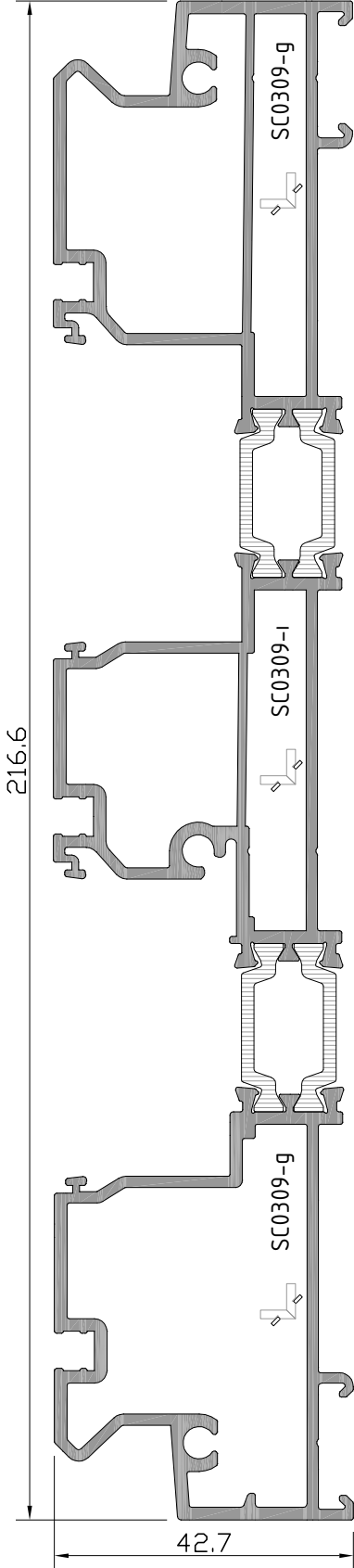

Profil No: S3-103

Ağırlık PVC : 3854	gr/m	Ix : 432,68cm ⁴
Ağırlık POLY : 3825	gr/m	Iy : 23,50 cm ⁴

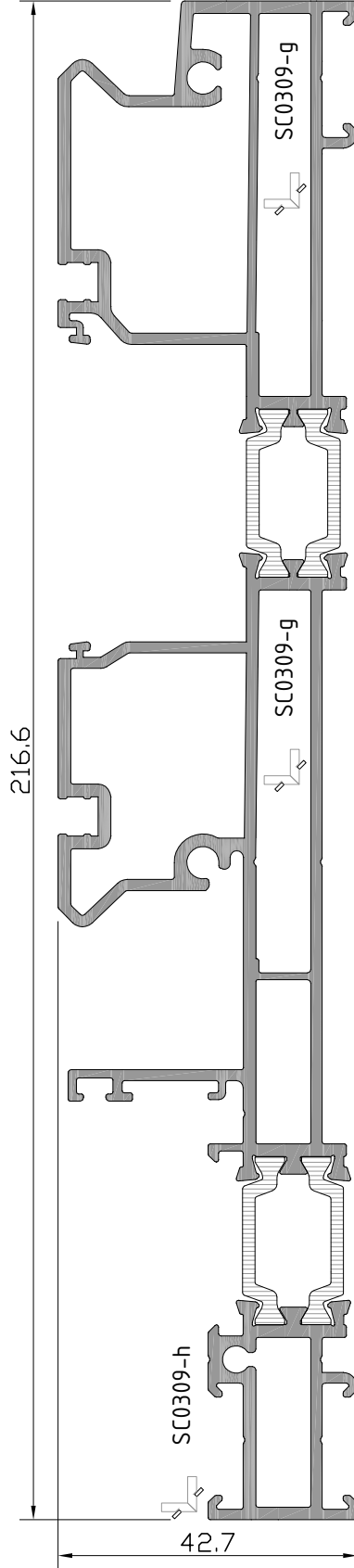

Profil No: S3-104

Ağırlık PVC : 3828	gr/m	Ix : 393,23cm ⁴
Ağırlık POLY : 3798	gr/m	Iy : 19,72 cm ⁴

S3
S65-T YALITIMLI SÜRME SERİ
S65 -T INSULATED SLIDING SERIES

ÜRÜN TEKNİK ÖZELLİKLERİ
PRODUCT'S TECHNICAL FEATURES

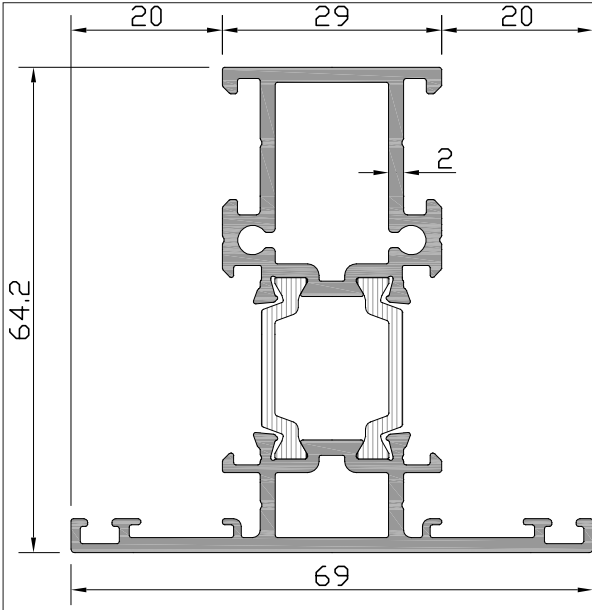

Profil No: **W6-301**

Ağırlık PVC :	1595	gr/m
Ağırlık POLY:	1581	gr/m
lx	: 20,84	cm ⁴
ly	: 9,43	cm ⁴



W-606-a
W-608-a
W-608\2-a



W-607-a

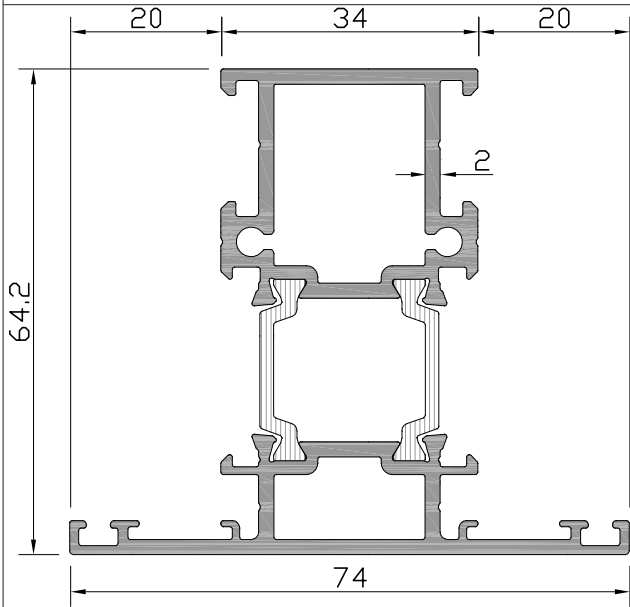

Profil No: **W6-308**

Ağırlık PVC :	1704	gr/m
Ağırlık POLY:	1689	gr/m
lx	: 22,55	cm ⁴
ly	: 12,65	cm ⁴



W-606-g
W-608-g
W-608\2-g



W-607-g

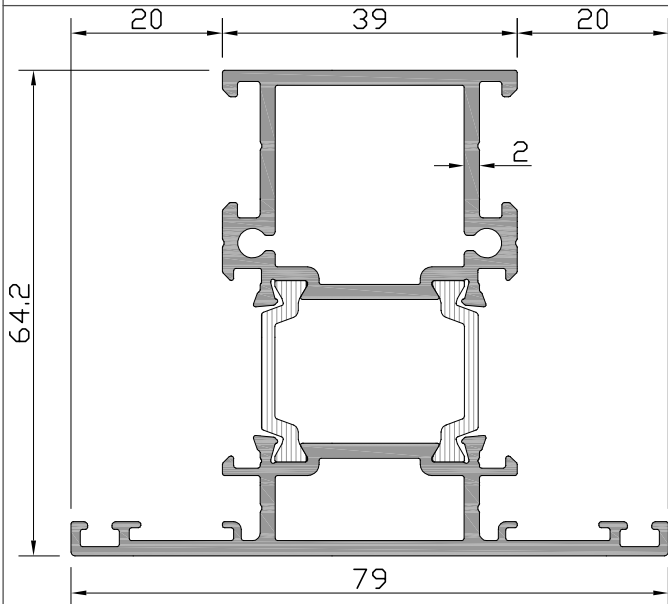

Profil No: **W6-302**

Ağırlık PVC :	1812	gr/m
Ağırlık POLY:	1798	gr/m
lx	: 24,26	cm ⁴
ly	: 16,59	cm ⁴



W-606-b
W-608-b
W-608\2-b



W-607-b

S3
S65-T YALITIMLI SÜRME SERİ
S65 -T INSULATED SLIDING SERIES

ÜRÜN TEKNİK ÖZELLİKLERİ
PRODUCT'S TECHNICAL FEATURES

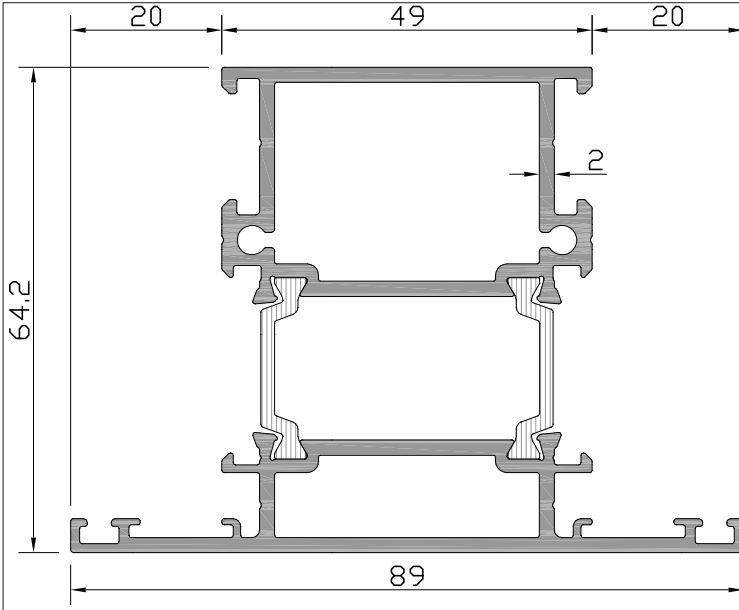

Profil No: W6-303

Ağırlık PVC :	2029	gr/m
Ağırlık POLY:	2014	gr/m
lx	: 27,65	cm ⁴
ly	: 26,76	cm ⁴



W-606-c

W-608-c

W-608\2-c



W-607-c

Profil No: S3-507

Ağırlık PVC :	2009	gr/m
Ağırlık POLY:	1995	gr/m
lx	97,89	cm ⁴
ly	6,78	cm ⁴

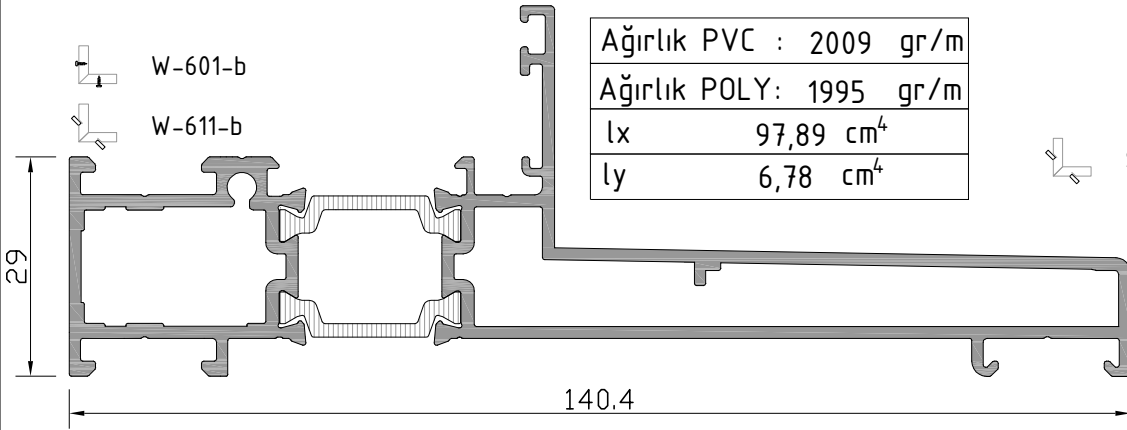

Profil No: S3-508 

Ağırlık PVC :	1497	gr/m	lx :	73,29	cm ⁴
Ağırlık POLY:	1482	gr/m	ly :	1,60	cm ⁴

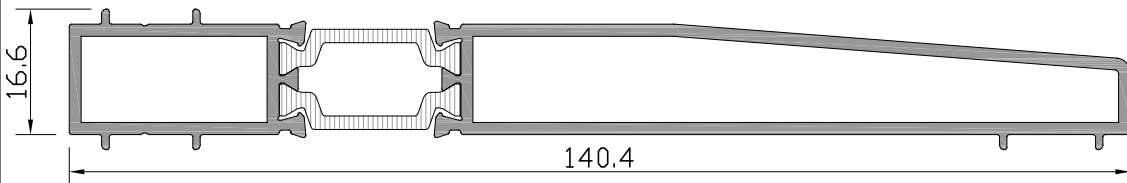

 İşareti profil için satış temsilcinizden bilgi alınız.

S3
S65-T YALITIMLI SÜRME SERİ
S65 -T INSULATED SLIDING SERIES

ÜRÜN TEKNİK ÖZELLİKLERİ
PRODUCT'S TECHNICAL FEATURES

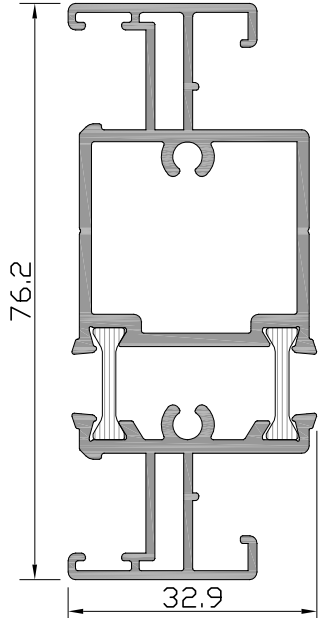

Profil No: S3-501

Ağırlık PVC : 1388 gr/m
Ağırlık POLY: 1379 gr/m

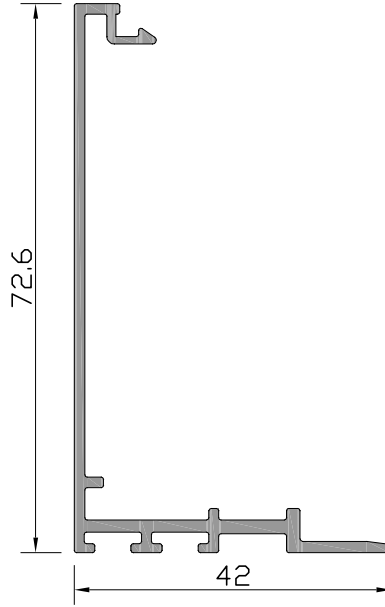

Profil No: S3-502

Ağırlık : 570 gr/m

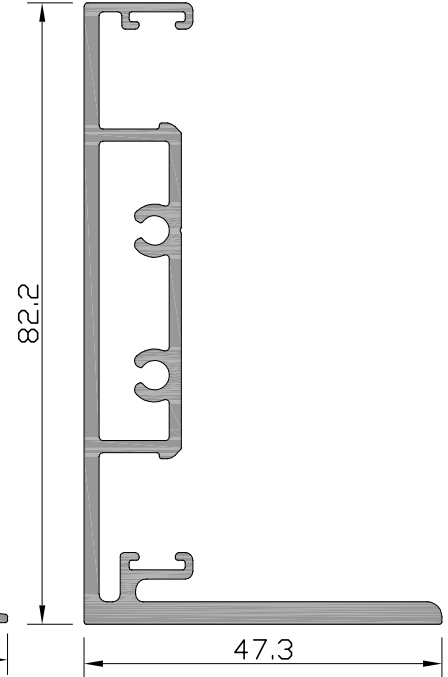

Profil No: S3-511

Ağırlık : 1300 gr/m

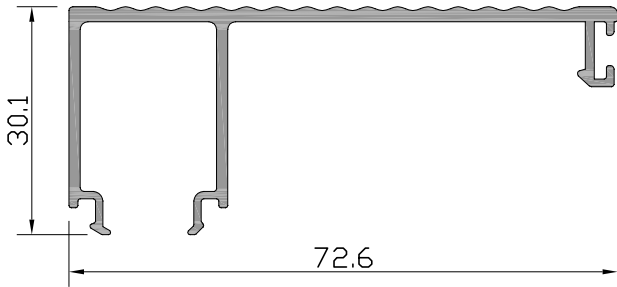

Profil No: S3-503

Ağırlık : 641 gr/m

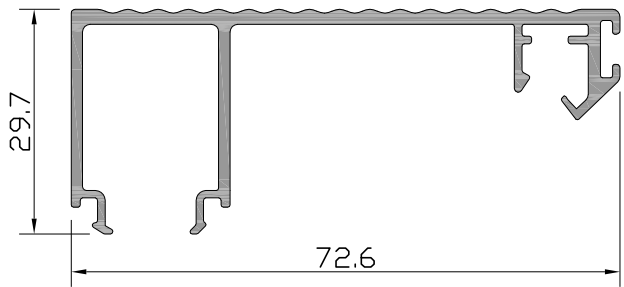

Profil No: S3-504

Ağırlık : 705 gr/m

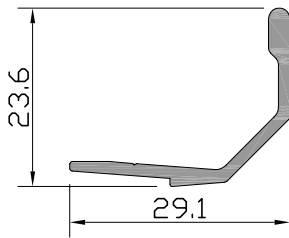

Profil No: S3-505

Ağırlık : 223 gr/m

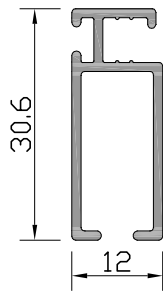

Profil No: S3-506

Ağırlık : 269 gr/m

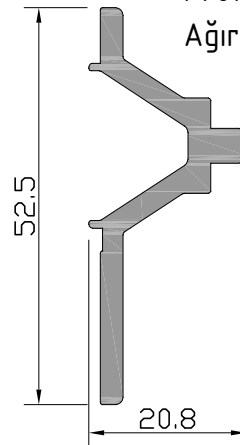

Profil No: S3-509

Ağırlık : 614 gr/m

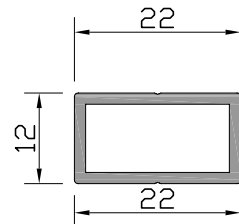

Profil No: S3-510 ⚠

Ağırlık : 251 gr/m

⚠ İşaretili profil için satış temsilcilerinizden bilgi alınız.

S3
S65-T YALITIMLI SÜRME SERİ
S65 -T INSULATED SLIDING SERIES

ÜRÜN TEKNİK ÖZELLİKLERİ
PRODUCT'S TECHNICAL FEATURES

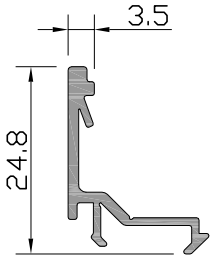

Profil No: W-511
Ağırlık : 189 gr/m

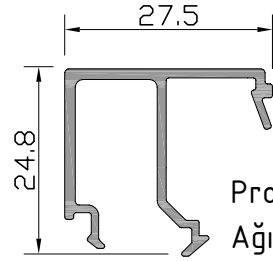

Profil No: W-517
Ağırlık : 300 gr/m

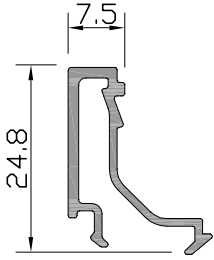

Profil No: W-512
Ağırlık : 220 gr/m

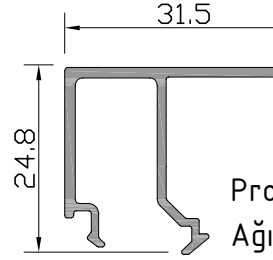

Profil No: W-518
Ağırlık : 318 gr/m

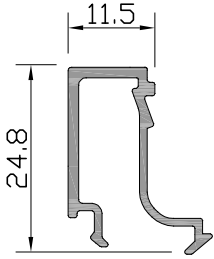

Profil No: W-513
Ağırlık : 232 gr/m

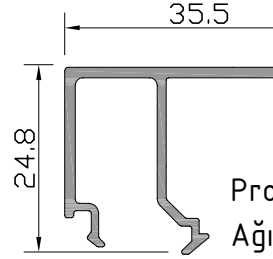

Profil No: W-519
Ağırlık : 337 gr/m

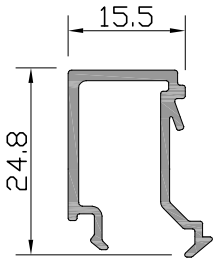

Profil No: W-514
Ağırlık : 254 gr/m

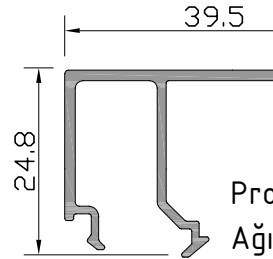

Profil No: W-520
Ağırlık : 352 gr/m

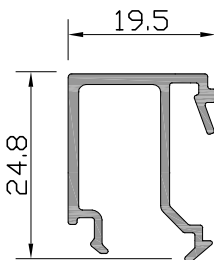

Profil No: W-515
Ağırlık : 274 gr/m

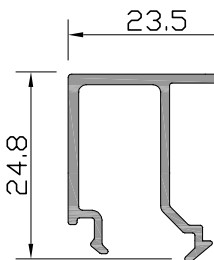

Profil No: W-516
Ağırlık : 287 gr/m

S3
S65-T YALITIMLI SÜRME SERİ
S65 - T INSULATED SLIDING SERIES

CAM - FİTİL - CAM ÇİTASI
GLAZING-GASKET-GLAZING BELT

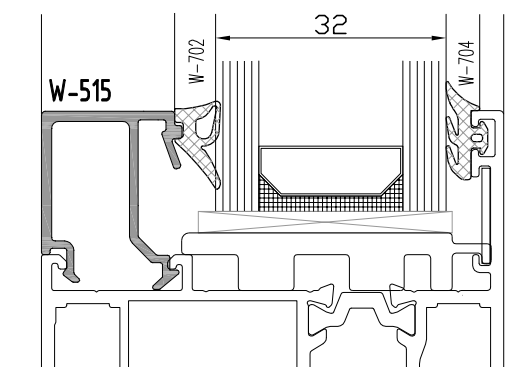
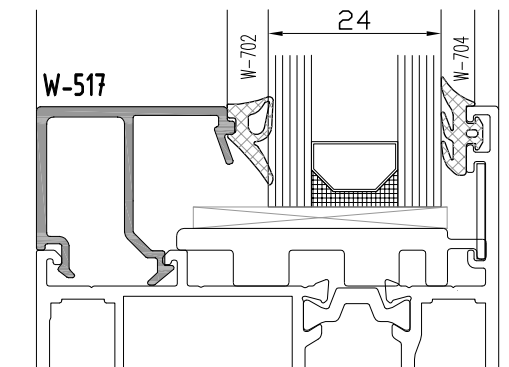
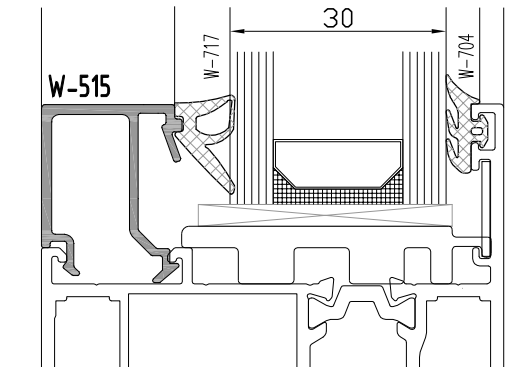
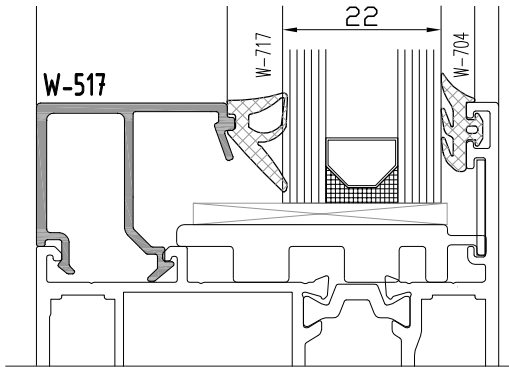
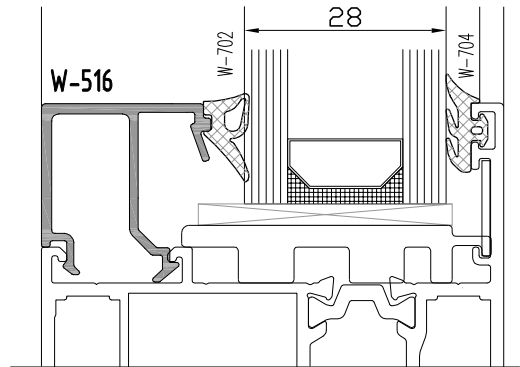
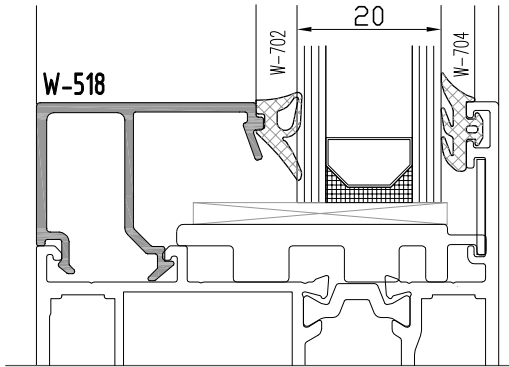
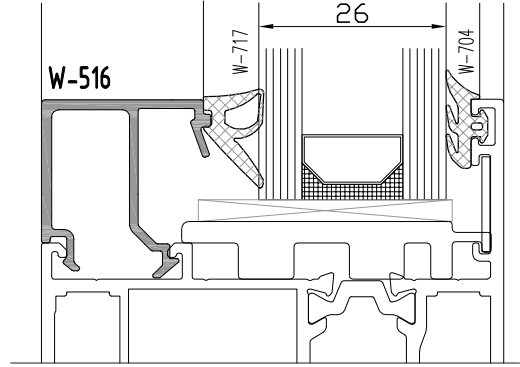
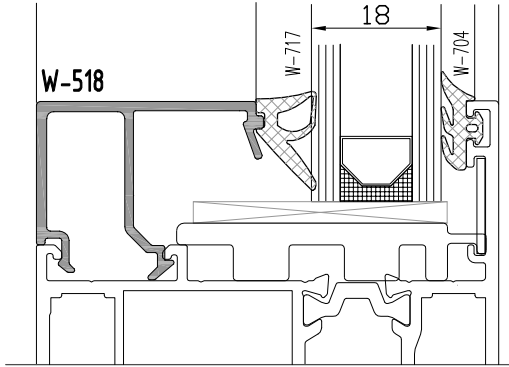

Profil değerleri teoriktir. Ağırlık olarak testimde yapılan tartım geçerlidir.
Profil imalatları TS EN 12020-2 ve TS EN 755-9 toleransı,
Moment değerleri EN 14024'e göre hesaplanmıştır.

Profile values are theoretical pre-shipment weight will be valid.
The tolerances of Profile manufacturing are calculated according to EN 12020-2
and TS EN 755-9; moment values are calculated according to EN 14024.

S3
S65-T YALITIMLI SÜRME SERİ
S65 -T INSULATED SLIDING SERIES

CAM - FİTİL - CAM ÇİTASI
GLAZING-GASKET-GLAZING BELT

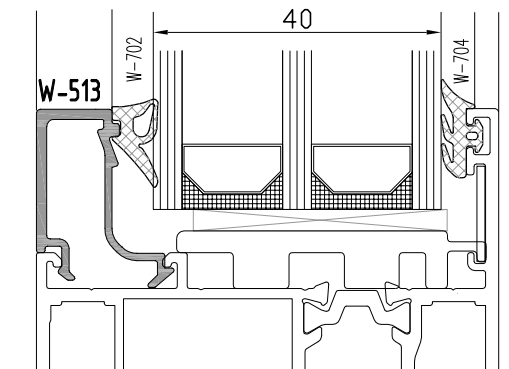
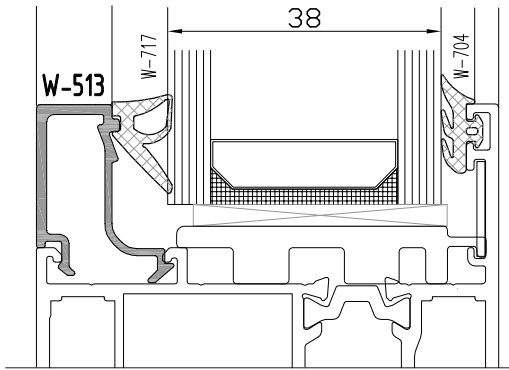
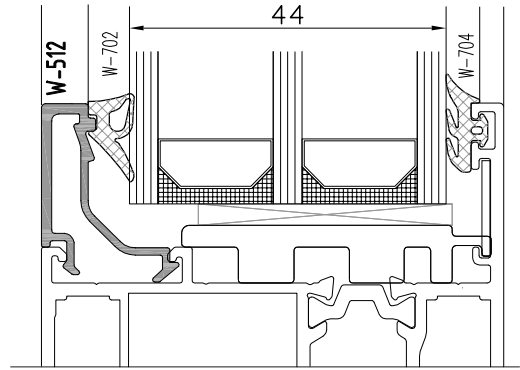
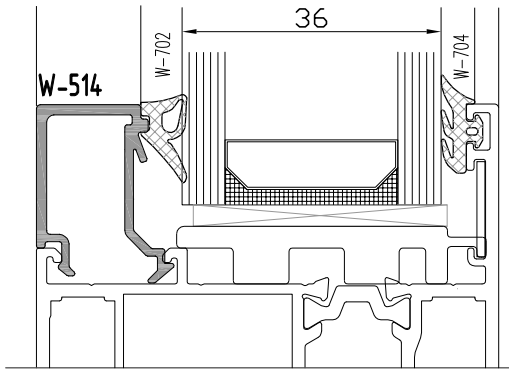
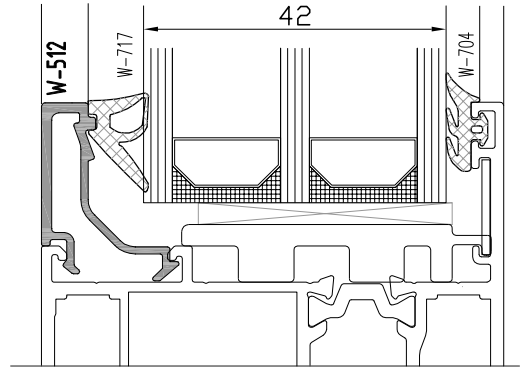
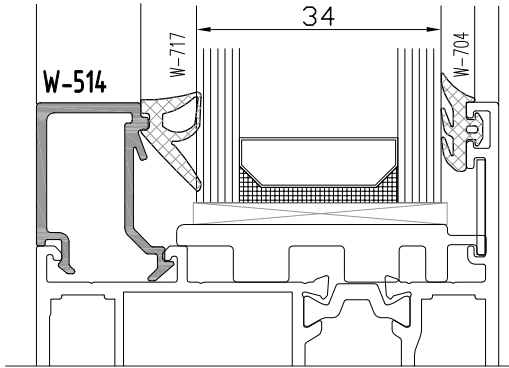

Profil değerleri teoriktir. Ağırlık olarak testimde yapılan tartım geçerlidir.
Profil imatları TS EN 12020-2 ve TS EN 755-9 toleransı,
Moment değerleri EN 14024'e göre hesaplanmıştır.

Profile values are theoretical pre-shipment weight will be valid.
The tolerances of Profile manufacturing are calculated according to EN 12020-2
and TS EN 755-9; moment values are calculated according to EN 14024.

S3
S65-T YALITIMLI SÜRME SERİ
S65 -T INSULATED SLIDING SERIES

ÜRÜN TEKNİK ÖZELLİKLERİ
PRODUCT'S TECHNICAL FEATURES

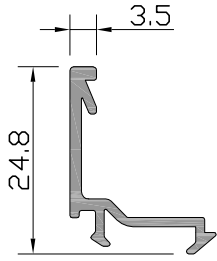

Profil No: W-511-a ⚠
Ağırlık : 195 gr/m

⚠ İşaretti profil için satış temsilcinizden bilgi alınız.

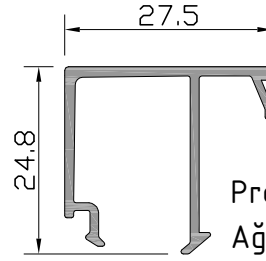

Profil No: W-517-a
Ağırlık : 286 gr/m

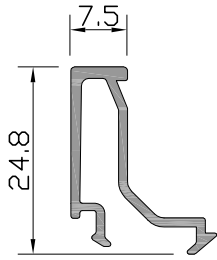

Profil No: W-512-a ⚠
Ağırlık : 228 gr/m

⚠ İşaretti profil için satış temsilcinizden bilgi alınız.

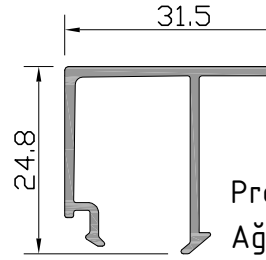

Profil No: W-518-a
Ağırlık : 299 gr/m

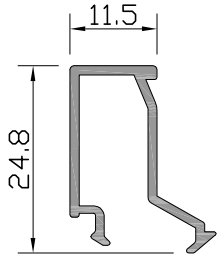

Profil No: W-513-a
Ağırlık : 218 gr/m

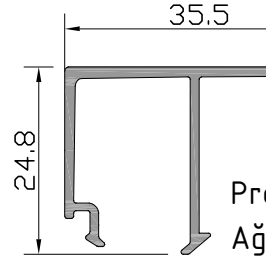

Profil No: W-519-a
Ağırlık : 319 gr/m

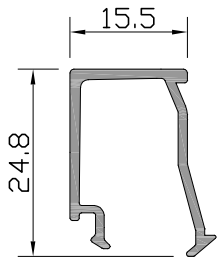

Profil No: W-514-a
Ağırlık : 231 gr/m

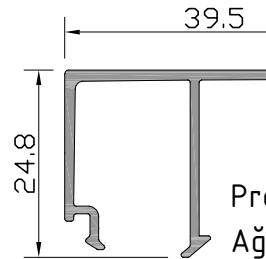

Profil No: W-520-a
Ağırlık : 332 gr/m

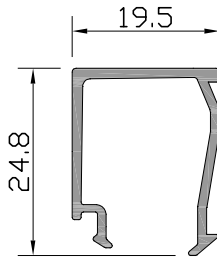

Profil No: W-515-a
Ağırlık : 244 gr/m

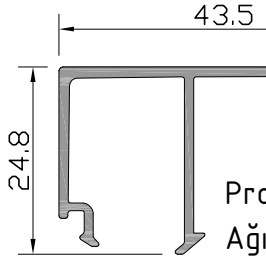

Profil No: W-521-a
Ağırlık : 346 gr/m

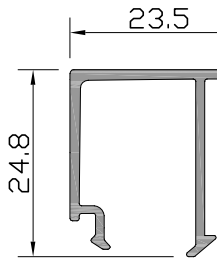

Profil No: W-516-a
Ağırlık : 273 gr/m

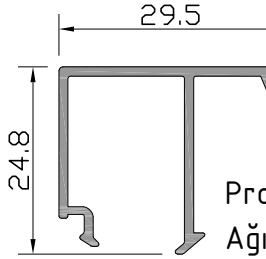

Profil No: W-522-a
Ağırlık : 281 gr/m

S3
S65-T YALITIMLI SÜRME SERİ
S65 -T INSULATED SLIDING SERIES

CAM - FİTİL - CAM ÇİTASI
GLAZING-GASKET-GLAZING BELT

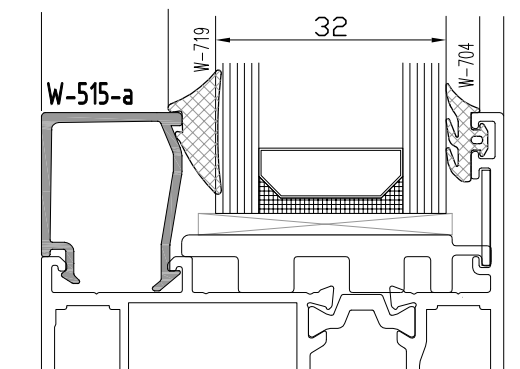
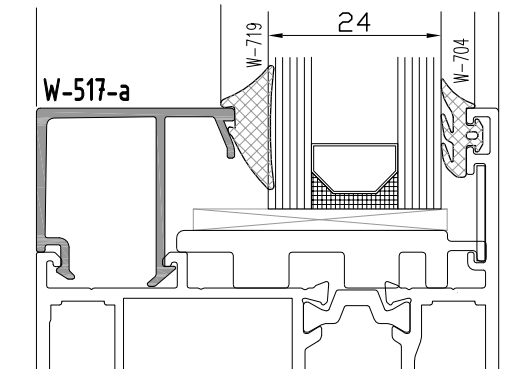
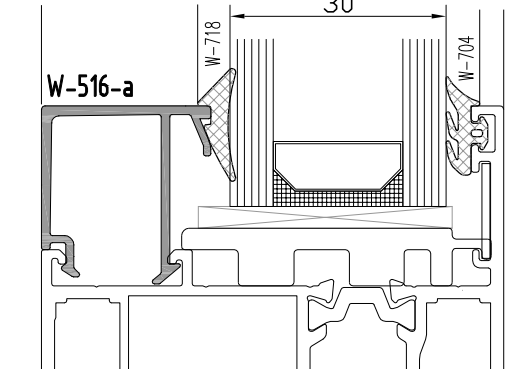
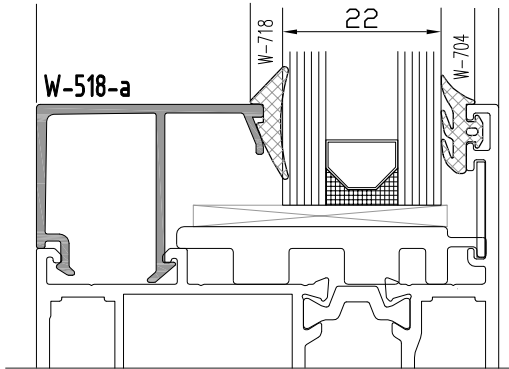
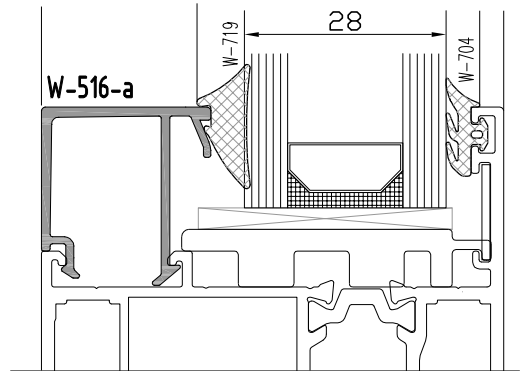
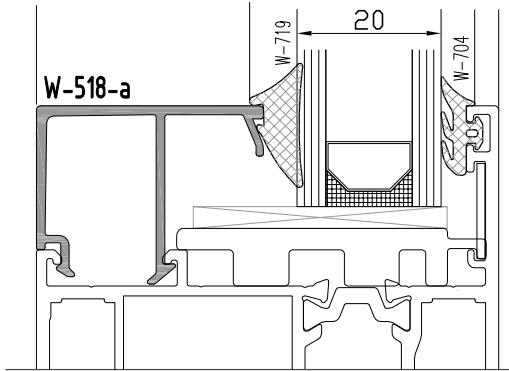
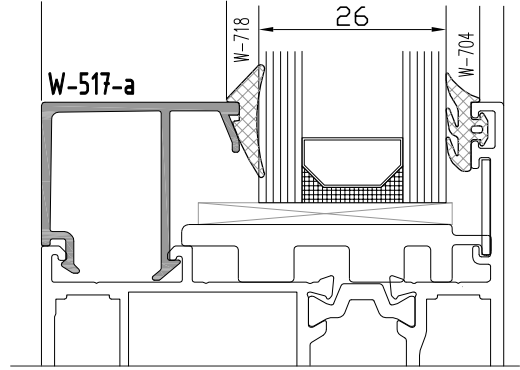
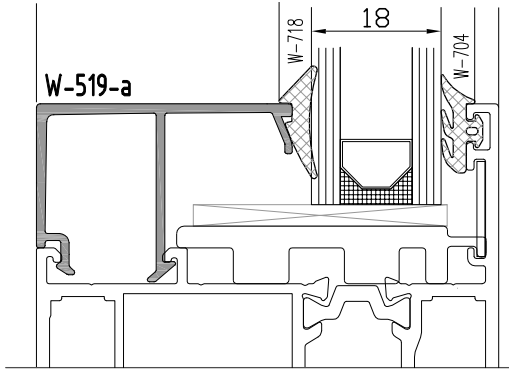

S3
S65-T YALITIMLI SÜRME SERİ
S65 -T INSULATED SLIDING SERIES

CAM - FİTİL - CAM ÇİTASI
GLAZING-GASKET-GLAZING BELT

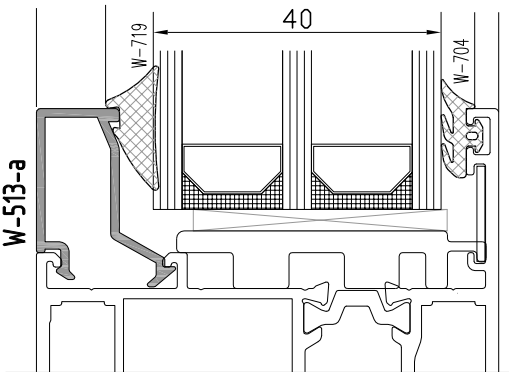
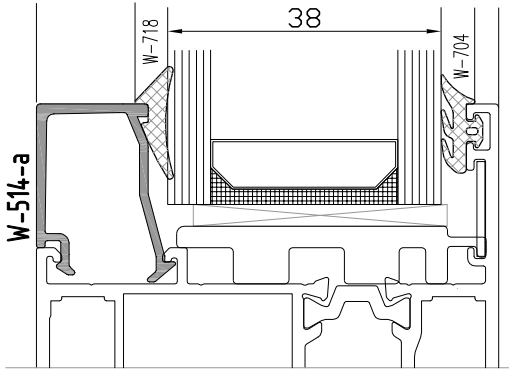
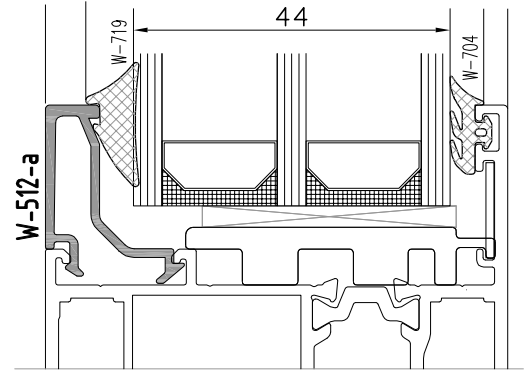
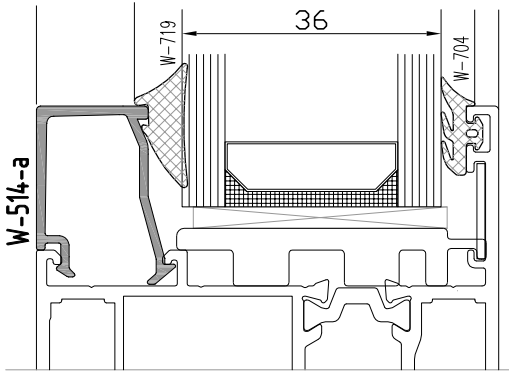
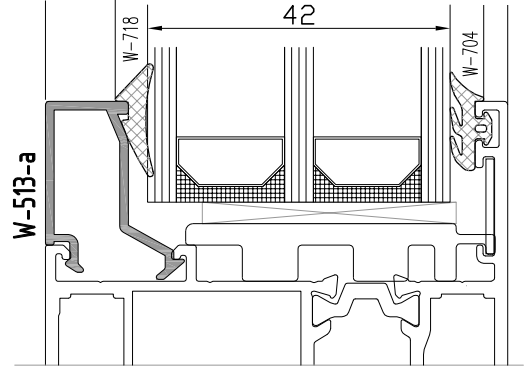
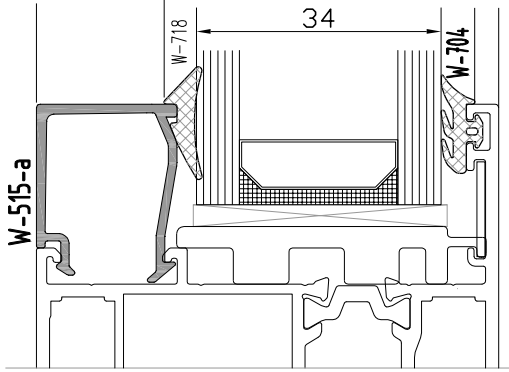

S3
S65-T YALITIMLI SÜRME SERİ
S65 -T INSULATED SLIDING SERIES

ÜRÜN TEKNİK ÖZELLİKLERİ
PRODUCT'S TECHNICAL FEATURES

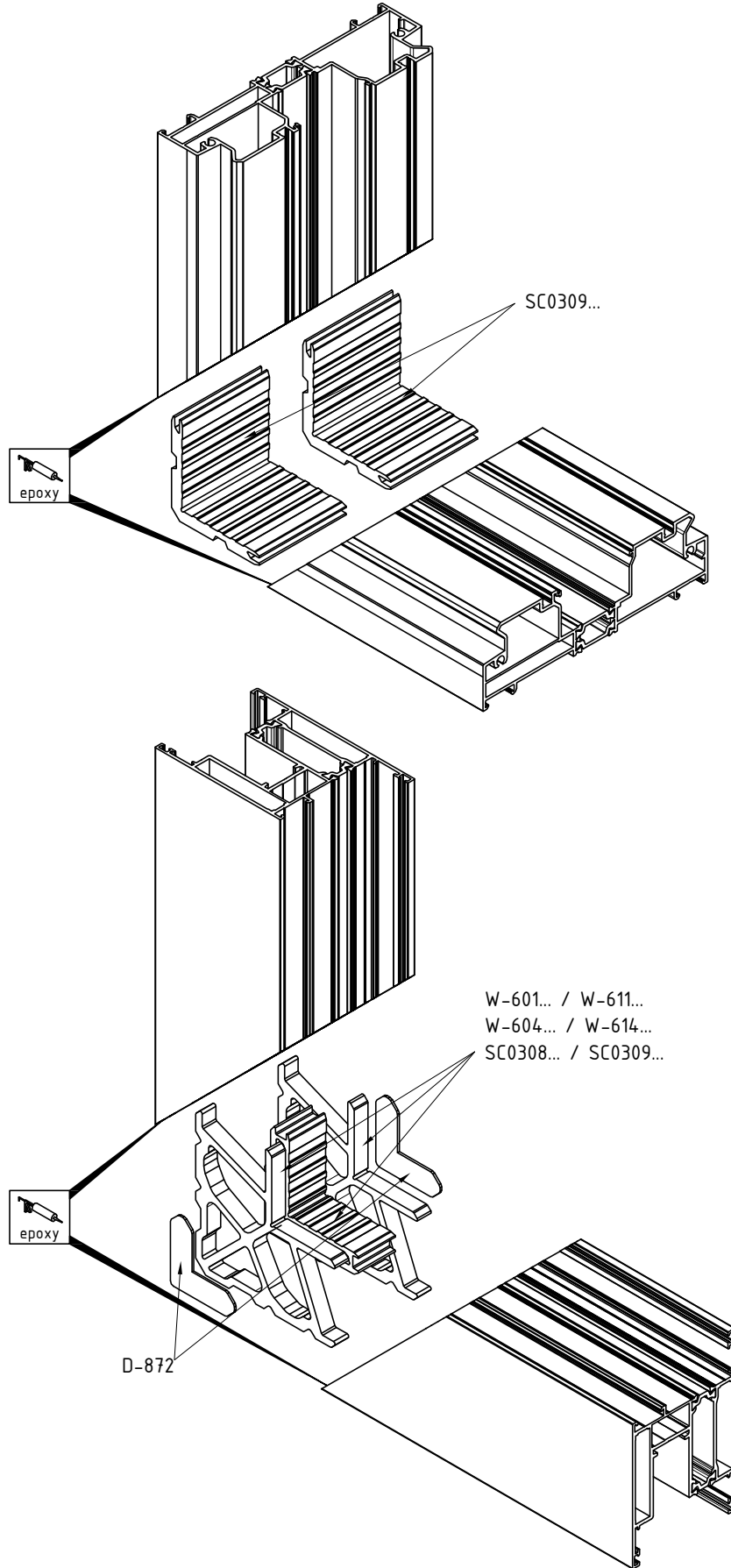

Profil değerleri teoriktir. Ağırlık olarak testimde yapılan tartım geçerlidir.
Profil imalatları TS EN 12020-2 ve TS EN 755-9 toleransı,
Moment değerleri EN 14024'e göre hesaplanmıştır.

Profile values are theoretical pre-shipment weight will be valid.
The tolerances of Profile manufacturing are calculated according to EN 12020-2
and TS EN 755-9; moment values are calculated according to EN 14024.

S3
S65-T YALITIMLI SÜRME SERİ
S65 -T INSULATED SLIDING SERIES

ÜRÜN TEKNİK ÖZELLİKLERİ
PRODUCT'S TECHNICAL FEATURES

Profil No: W-601

Ağırlık : 3428 gr/m

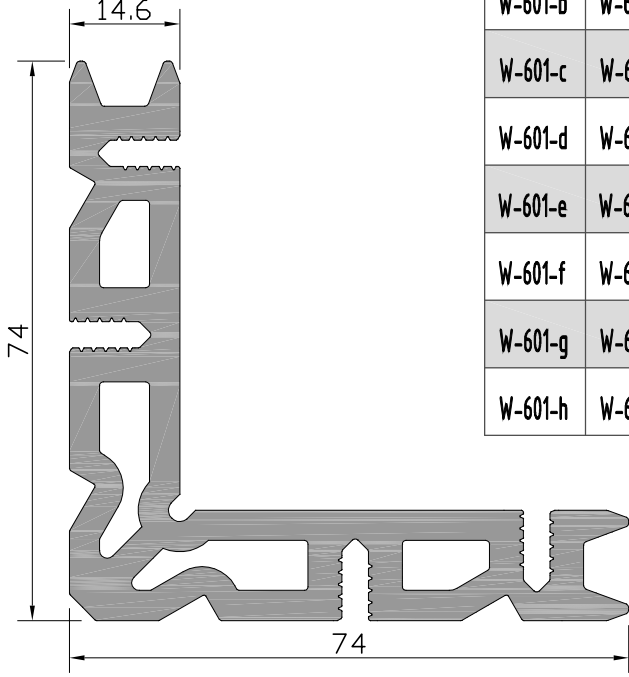

W-601-a	W-611-a	8.2mm	100 adet/pcs
W-601-b	W-611-b	23.6mm	100 adet/pcs
W-601-c	W-611-c	6mm	100 adet/pcs
W-601-d	W-611-d	25.3mm	100 adet/pcs
W-601-e	W-611-e	50.1mm	100 adet/pcs
W-601-f	W-611-f	50.6mm	100 adet/pcs
W-601-g	W-611-g	41.7mm	100 adet/pcs
W-601-h	W-611-h	4.7mm	100 adet/pcs

Profil No: W-611

Ağırlık : 3044 gr/m

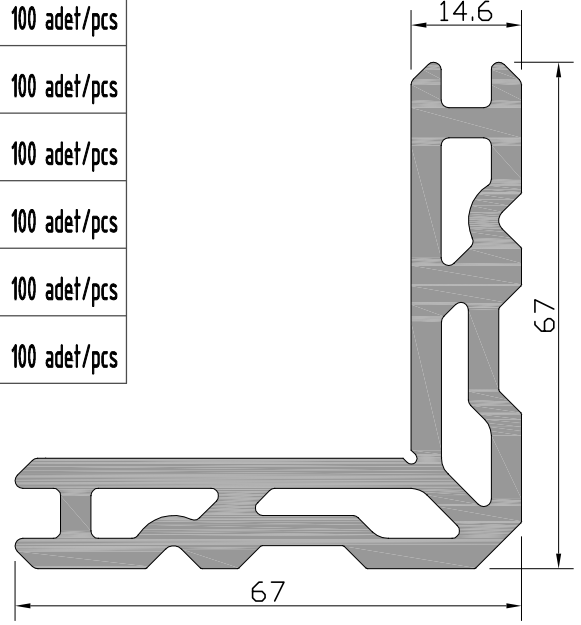

Profil No: W-604

Ağırlık : 5539 gr/m

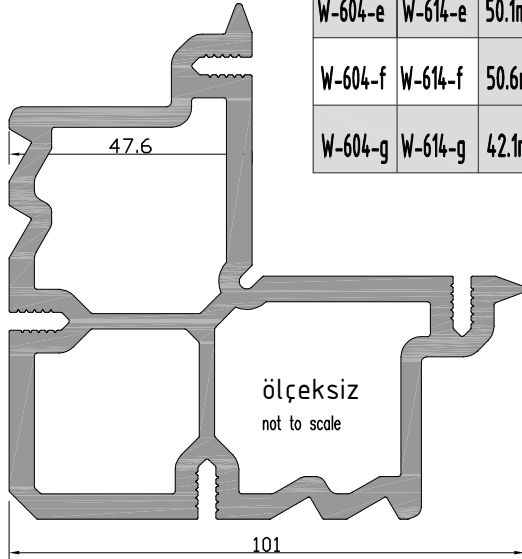

W-604-a	W-614-a	6mm	25 adet/pcs	W-604-h	W-614-h	20mm	25 adet/pcs
W-604-b	W-614-b	25.3mm	25 adet/pcs	W-604-ı	W-614-ı	5.3mm	25 adet/pcs
W-604-c	W-614-c	23.4mm	25 adet/pcs	W-604-j	W-614-j	43.3mm	25 adet/pcs
W-604-d	W-614-d	14mm	25 adet/pcs	W-604-k	W-614-k	7.5mm	25 adet/pcs
W-604-e	W-614-e	50.1mm	25 adet/pcs	W-604-l	W-614-l	18.6mm	25 adet/pcs
W-604-f	W-614-f	50.6mm	25 adet/pcs	W-604-m	W-614-m	11.9mm	25 adet/pcs
W-604-g	W-614-g	42.1mm	25 adet/pcs	W-604-n	W-614-n	41.8mm	25 adet/pcs
				W-604-o	W-614-o	8.5mm	25 adet/pcs

Profil No: W-614

Ağırlık : 5325 gr/m

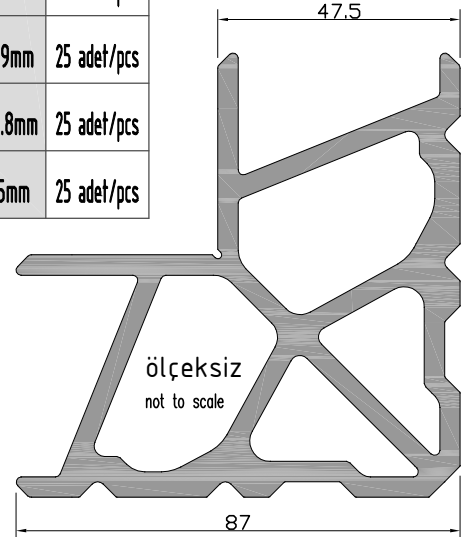

S3
S65-T YALITIMLI SÜRME SERİ
S65 -T INSULATED SLIDING SERIES

ÜRÜN TEKNİK ÖZELLİKLERİ
PRODUCT'S TECHNICAL FEATURES

SC0308-a	25.68mm	100 adet/pcs
SC0308-b	29.74mm	100 adet/pcs
SC0308-c	24.36mm	100 adet/pcs
SC0308-d	10.30mm	100 adet/pcs
SC0308-e	6.70mm	100 adet/pcs
SC0308-f	23mm	100 adet/pcs

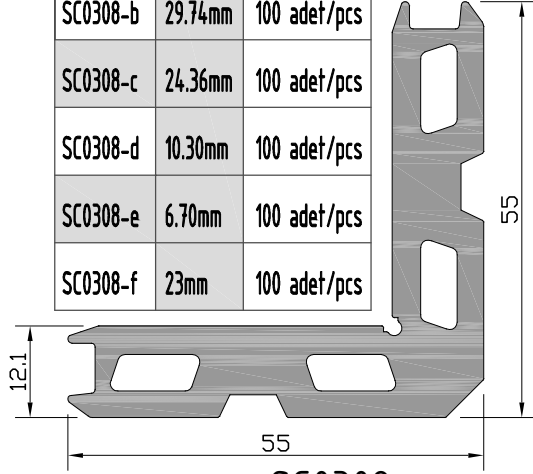

Profil No: SC0308
Ağırlık : 2313 gr/m

SC0309-a	6.5mm	100 adet/pcs
SC0309-b	8.5mm	100 adet/pcs
SC0309-c	18.9mm	100 adet/pcs
SC0309-d	20mm	100 adet/pcs
SC0309-e	25.3mm	100 adet/pcs
SC0309-f	4.7mm	100 adet/pcs
SC0309-g	54.2mm	100 adet/pcs
SC0309-h	23.8mm	100 adet/pcs
SC0309-ı	48.2mm	100 adet/pcs

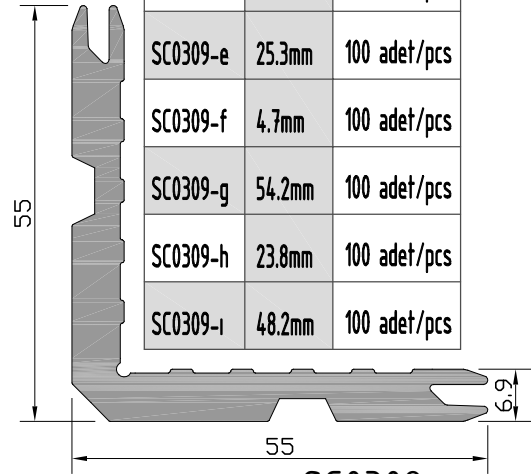

Profil No: SC0309
Ağırlık : 2313 gr/m

W-606-a	W-607-a	W-608-a	14.6mm	100 adet/pcs
W-606-b	W-607-b	W-608-b	24.6mm	100 adet/pcs
W-606-c	W-607-c	W-608-c	34.6mm	100 adet/pcs
W-606-d	W-607-d	W-608-d	55.6mm	100 adet/pcs
W-606-e	W-607-e	W-608-e	80.3mm	100 adet/pcs
W-606-f	W-607-f	W-608-f	110.6mm	100 adet/pcs
W-606-g	W-607-g	W-608-g	19.6mm	100 adet/pcs

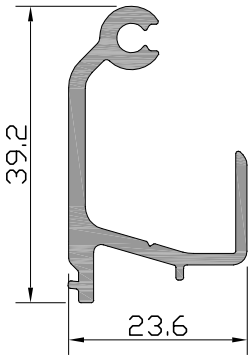

Profil No: W-606
Ağırlık : 482gr/m

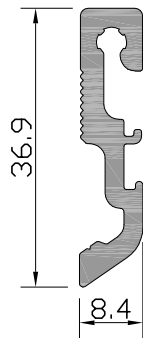

Profil No: W-607
Ağırlık : 431 gr/m

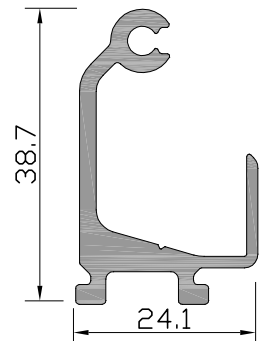

Profil No: W-608
Ağırlık : 583 gr/m

S3
S65-T YALITIMLI SÜRME SERİ
S65 -T INSULATED SLIDING SERIES

ORTA KAYIT BAĞLANTI
T - CONNECTOR

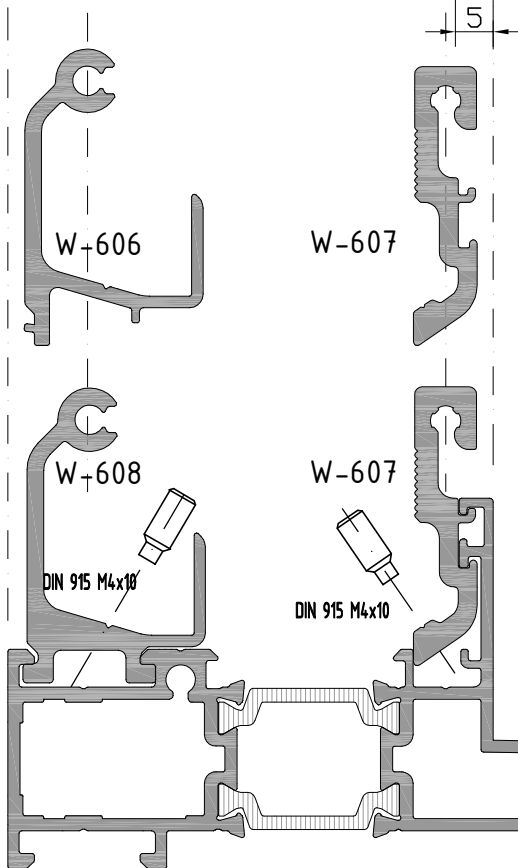
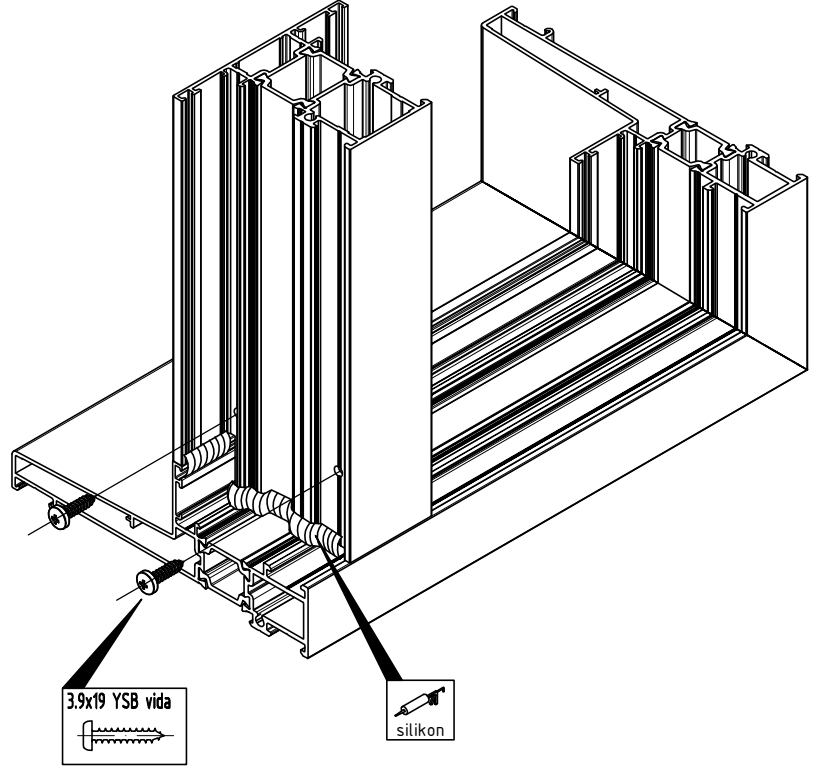
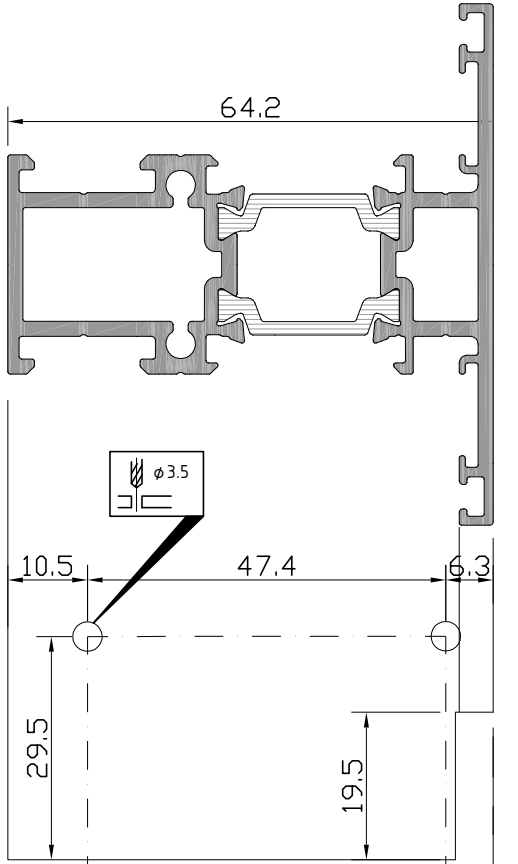

S3
S65-T YALITIMLI SÜRME SERİ
S65 -T INSULATED SLIDING SERIES

ORTA KAYIT BAĞLANTI
T - CONNECTOR

Profil No: S3-601

Ağırlık : 546 gr/m

S3-601-a	47.5mm	100 adet/pcs
----------	--------	--------------

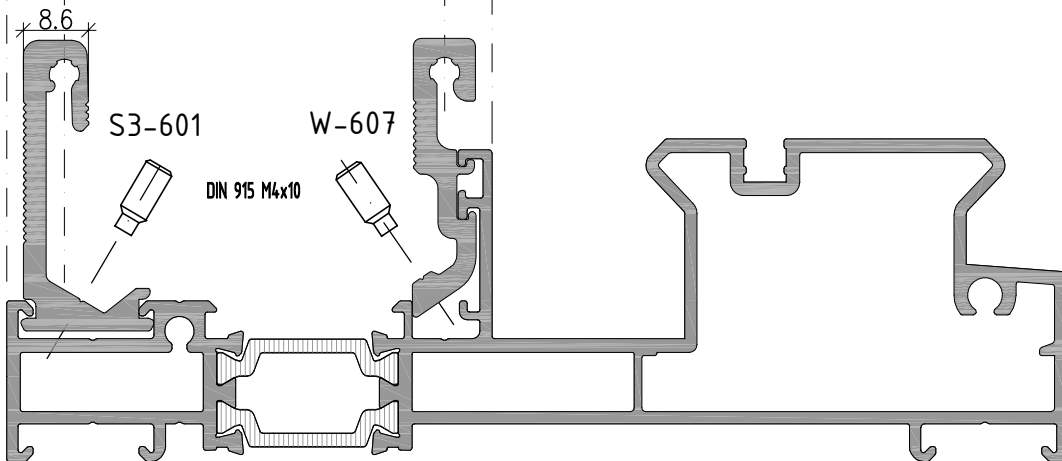
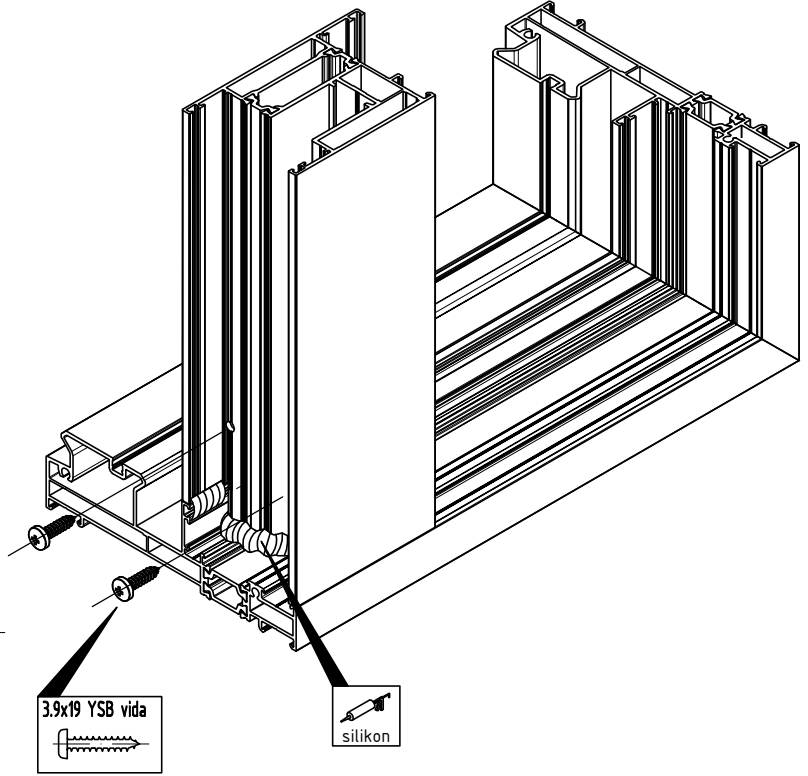
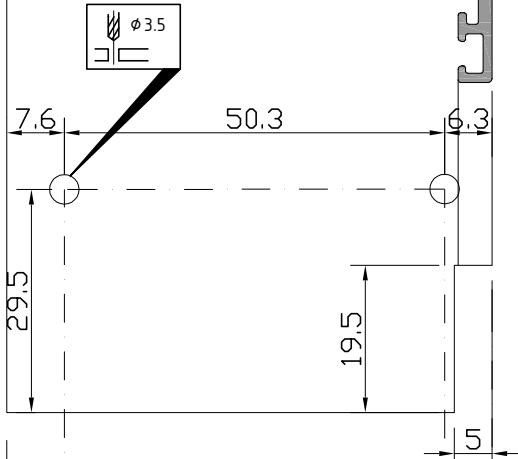
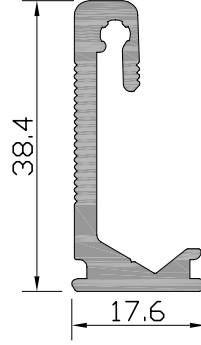
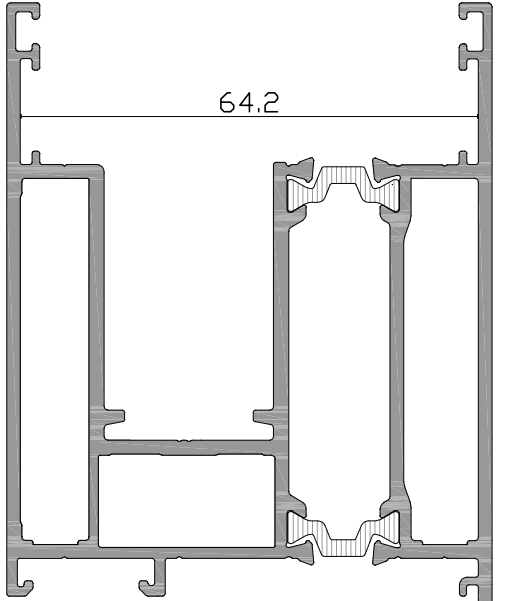

Profil değerleri teoriktir. Ağırlık olarak testimde yapılan tartım geçerlidir.
Profil imalatları TS EN 12020-2 ve TS EN 755-9 toleransı,
Moment değerleri EN 14024'e göre hesaplanmıştır.

Profile values are theoretical pre-shipment weight will be valid.
The tolerances of Profile manufacturing are calculated according to EN 12020-2
and TS EN 755-9; moment values are calculated according to EN 14024.

S3

S 65-T YALITIMLI SÜRME SERİ

S65 -T INSULATED SLIDING SERIES

YAN BİTİM - ORTA KAYIT DETAYI
WALL CONNECTION - MULLION DETAIL

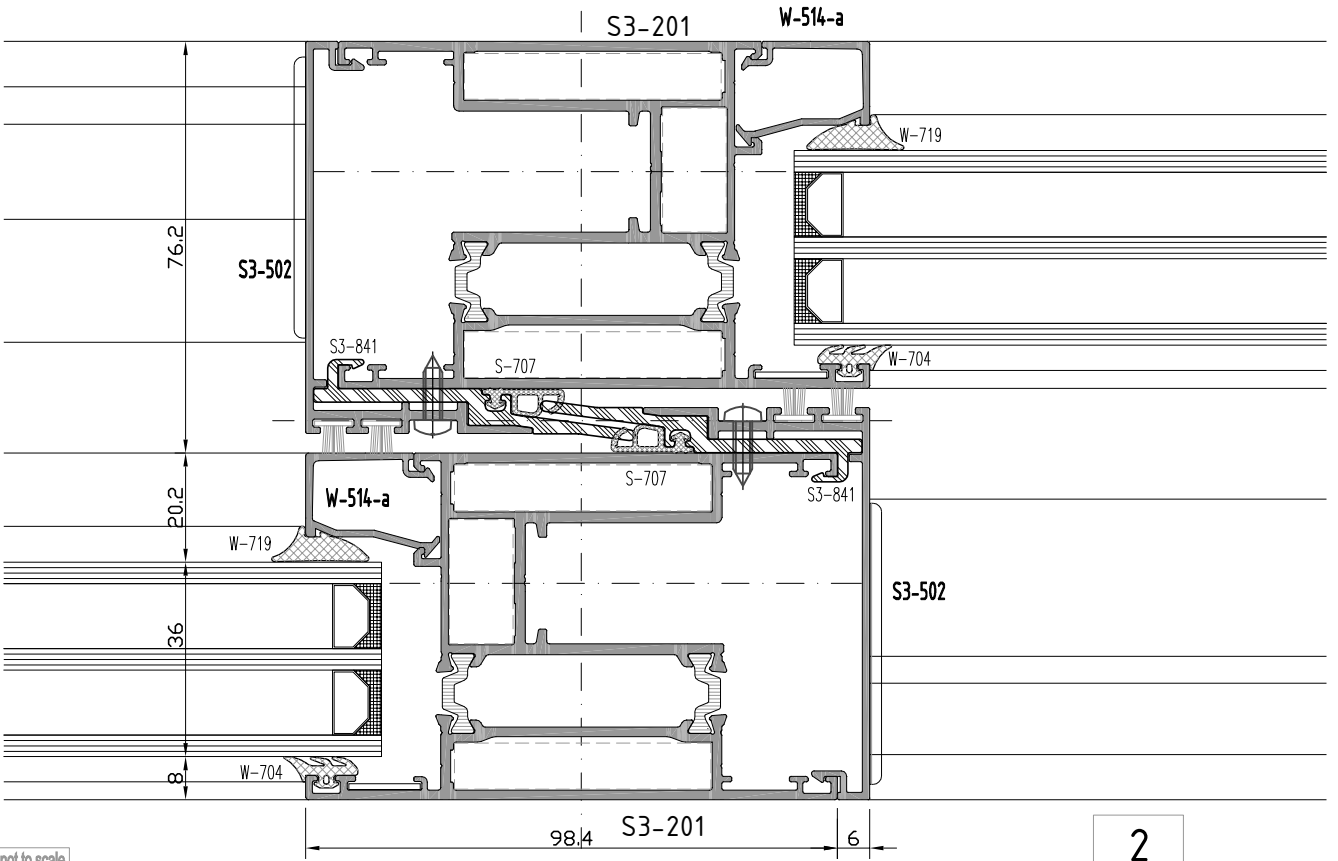
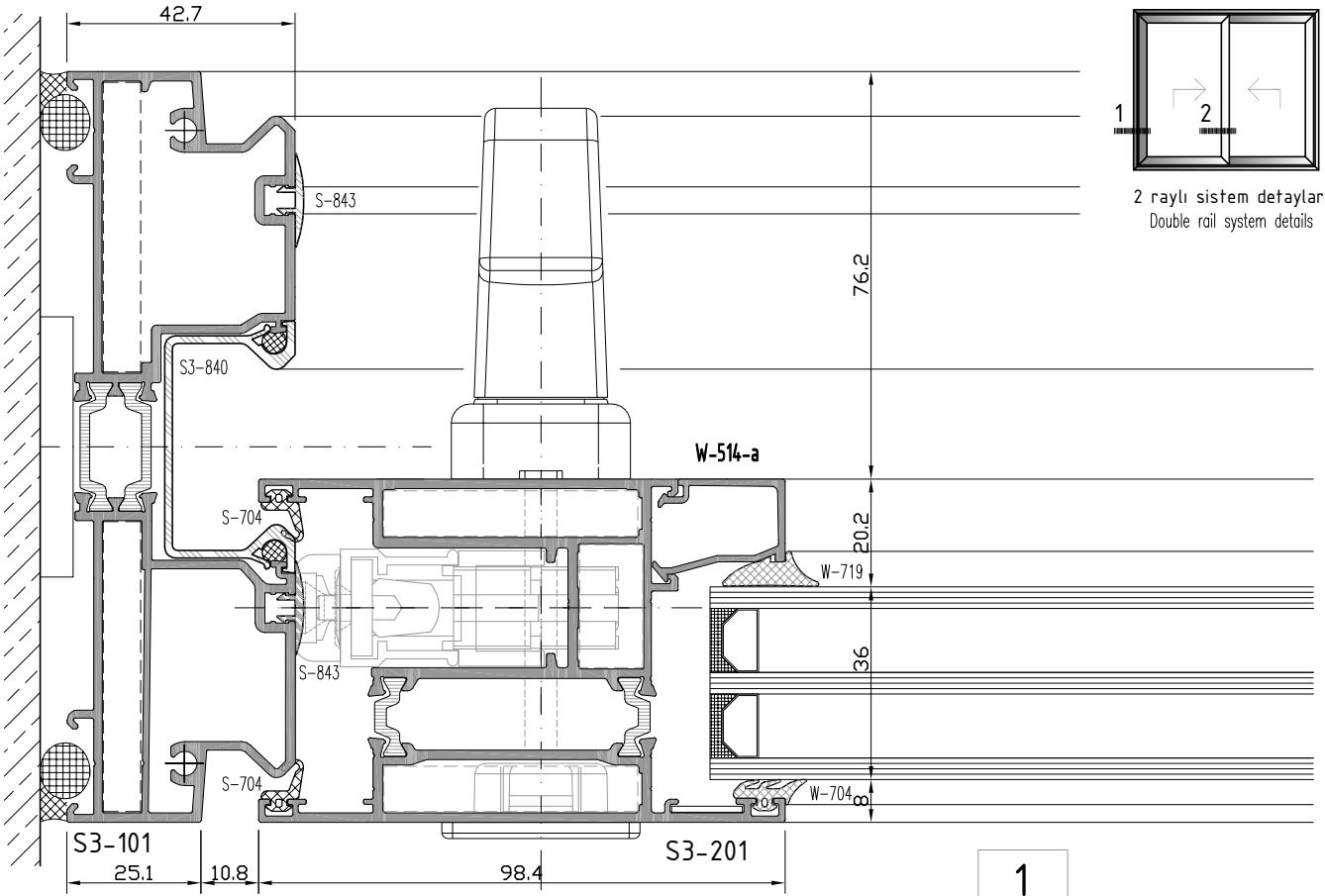

not to scale

S3

S 65-T YALITIMLI SÜRME SERİ

S65 -T INSULATED SLIDING SERIES

YAN BİTİM DETAYI

WALL CONNECTION DETAIL

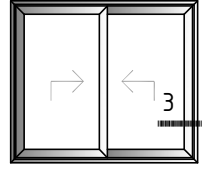

2 raylı sistem detayları
Double rail system details

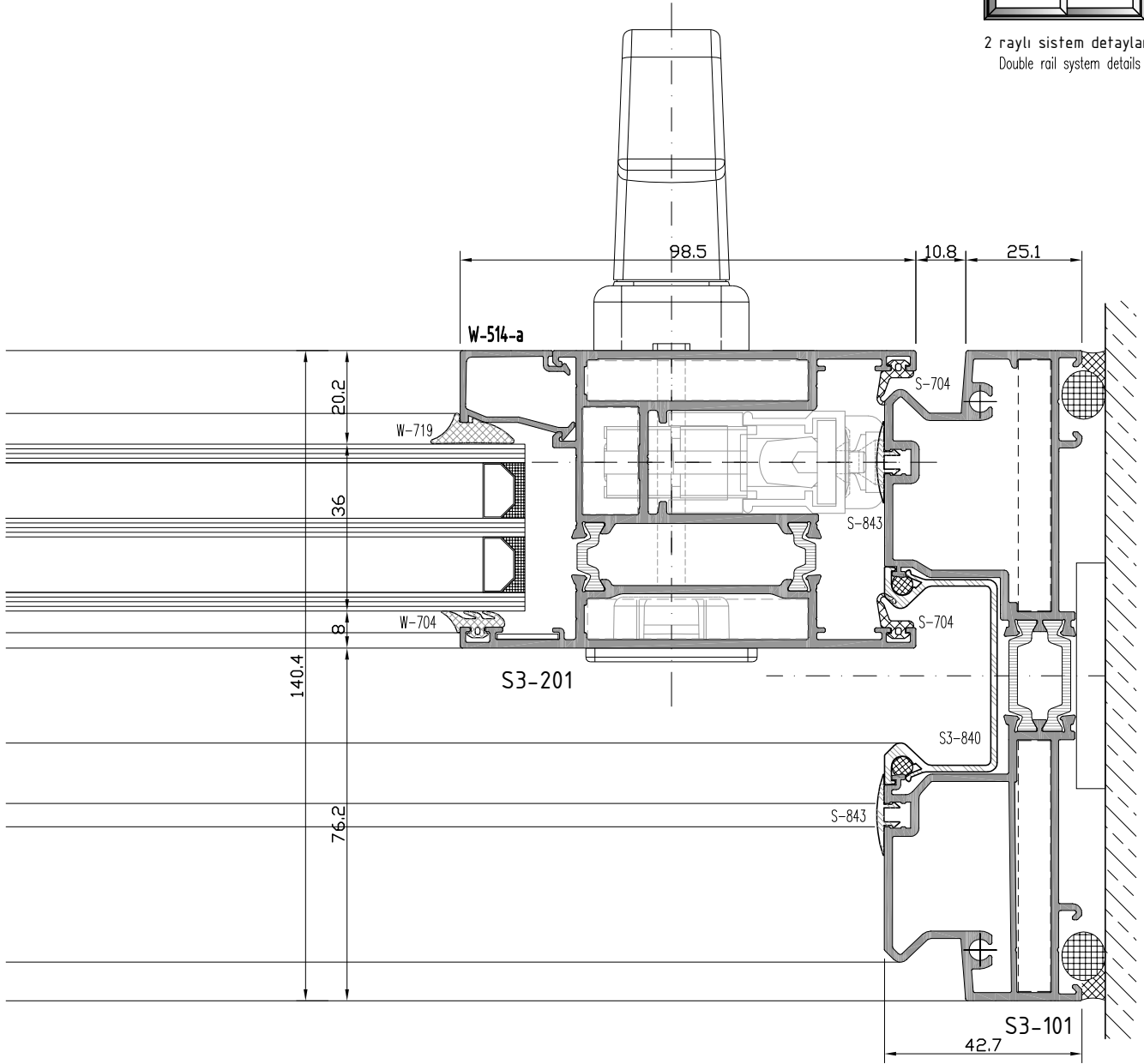

3

S3

S 65-T YALITIMLI SÜRME SERİ

S65 -T INSULATED SLIDING SERIES

ÜST BİTİM - ALT BİTİM DETAYI
TOP EDGE - BOTTOM EDGE DETAIL

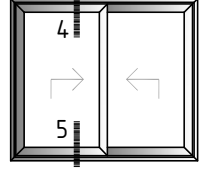
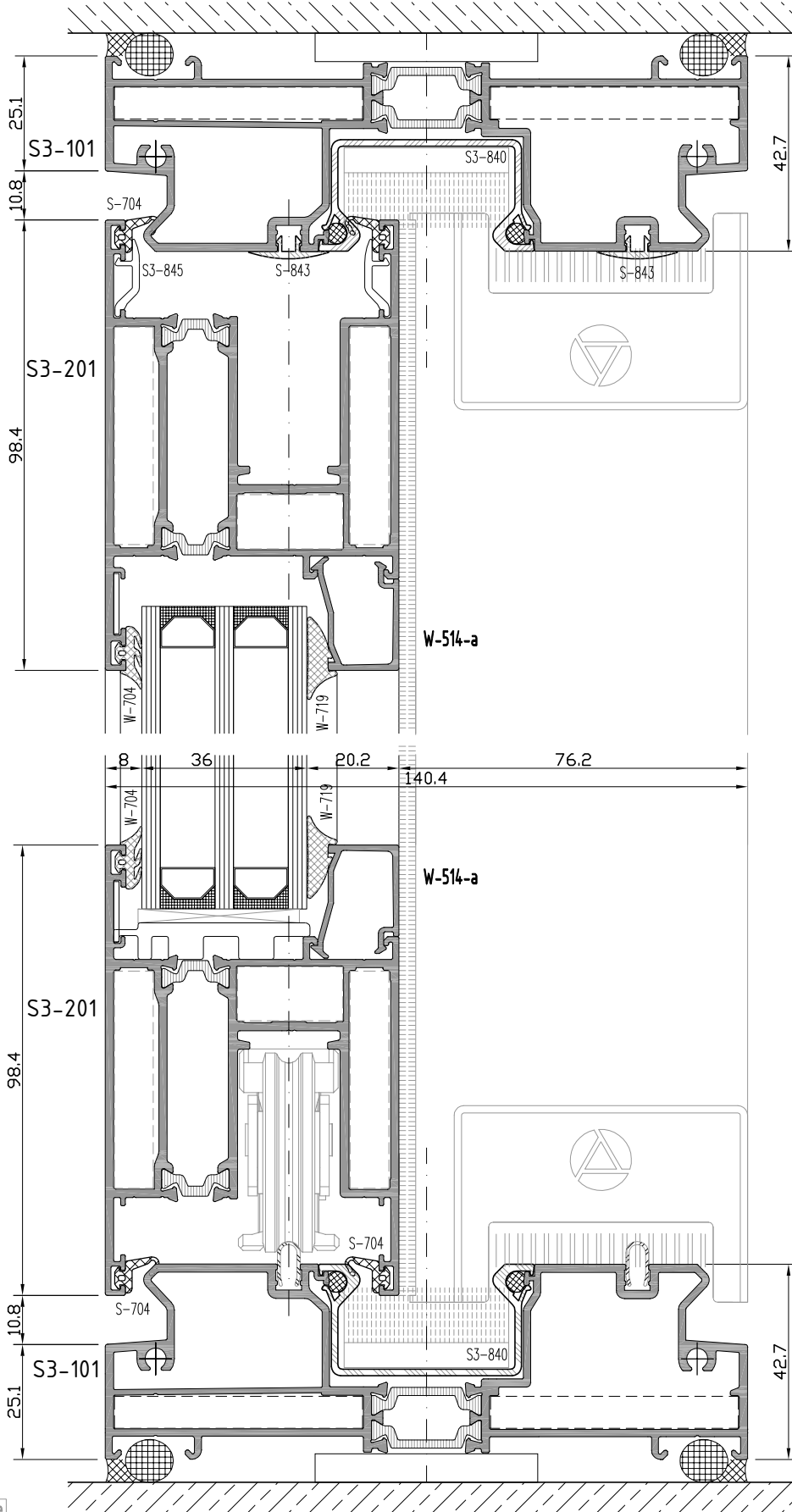

2 raylı sistem detayları
Double rail system details

4

5

not to scale

S3

S 65-T YALITIMLI SÜRME SERİ

S65 -T INSULATED SLIDING SERIES

ORTA KAYIT DETAYI

MULLION DETAIL

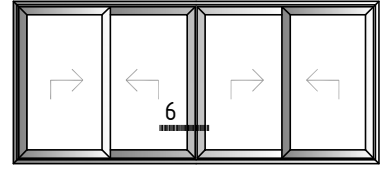

2 raylı sistem detayları
Double rail system details

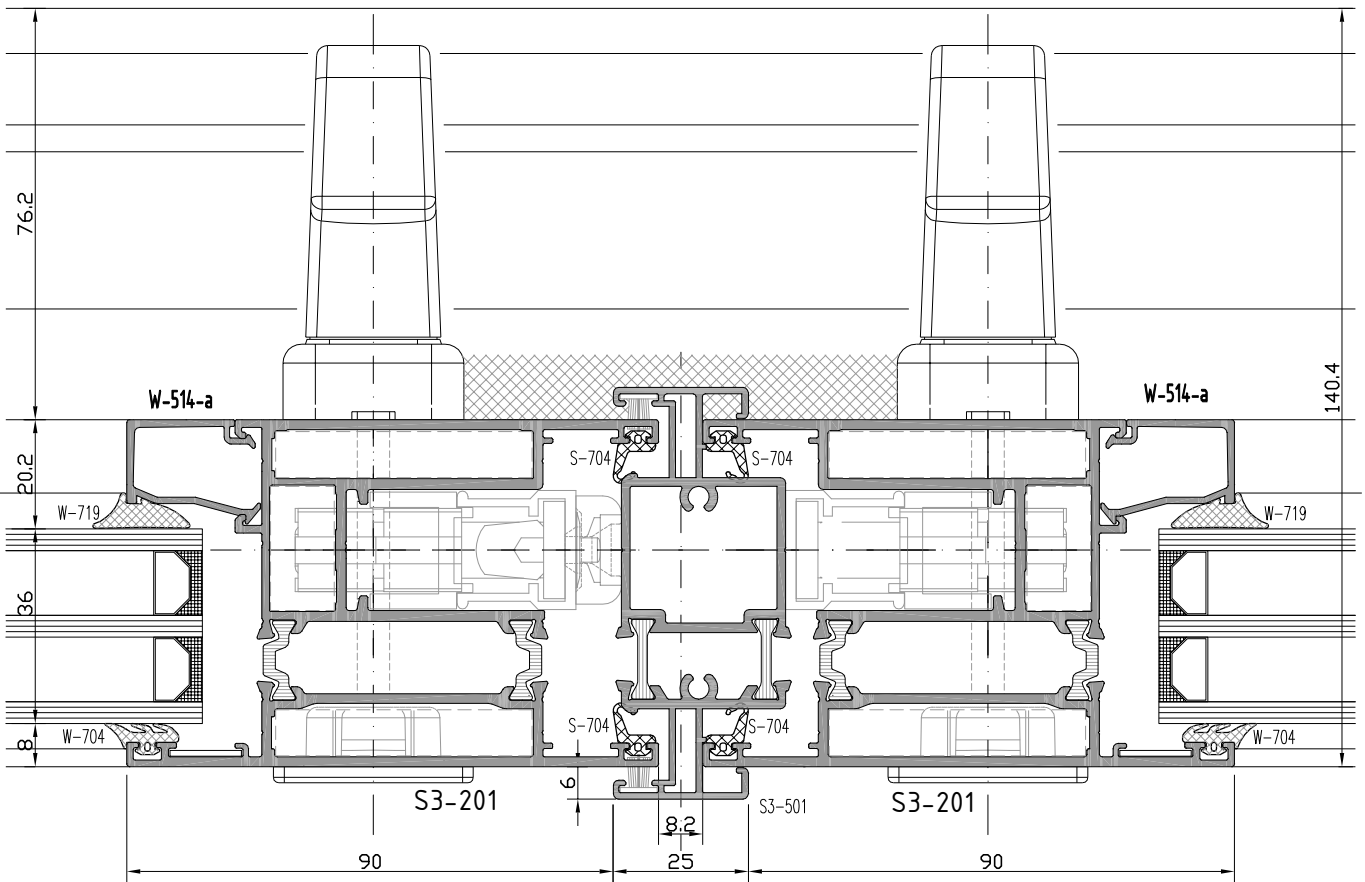

6

not to scale

S3

S 65-T YALITIMLI SÜRME SERİ

S65 -T INSULATED SLIDING SERIES

YAN BİTİM - ORTA KAYIT DETAYI
WALL CONNECTION - MULLION DETAIL

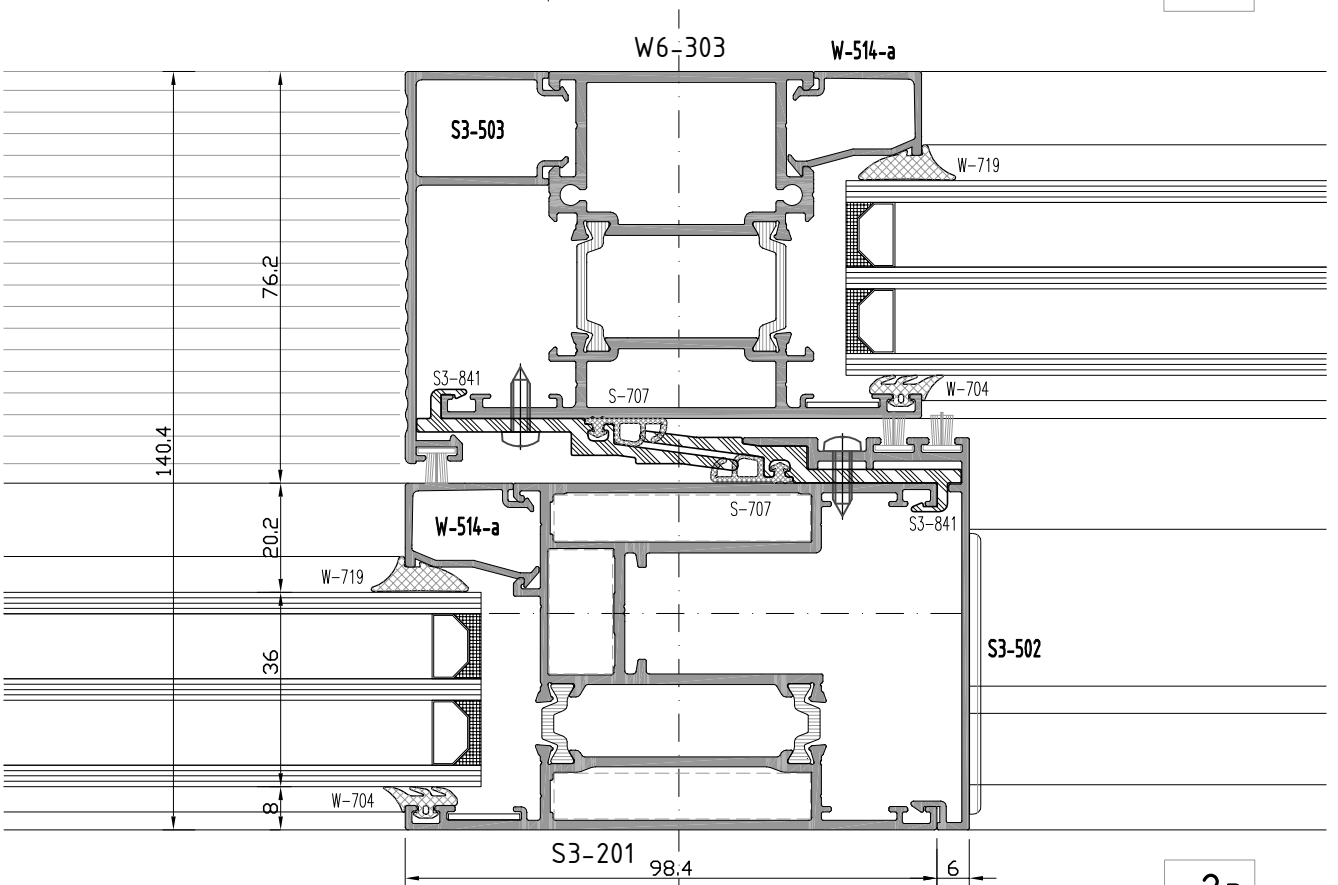
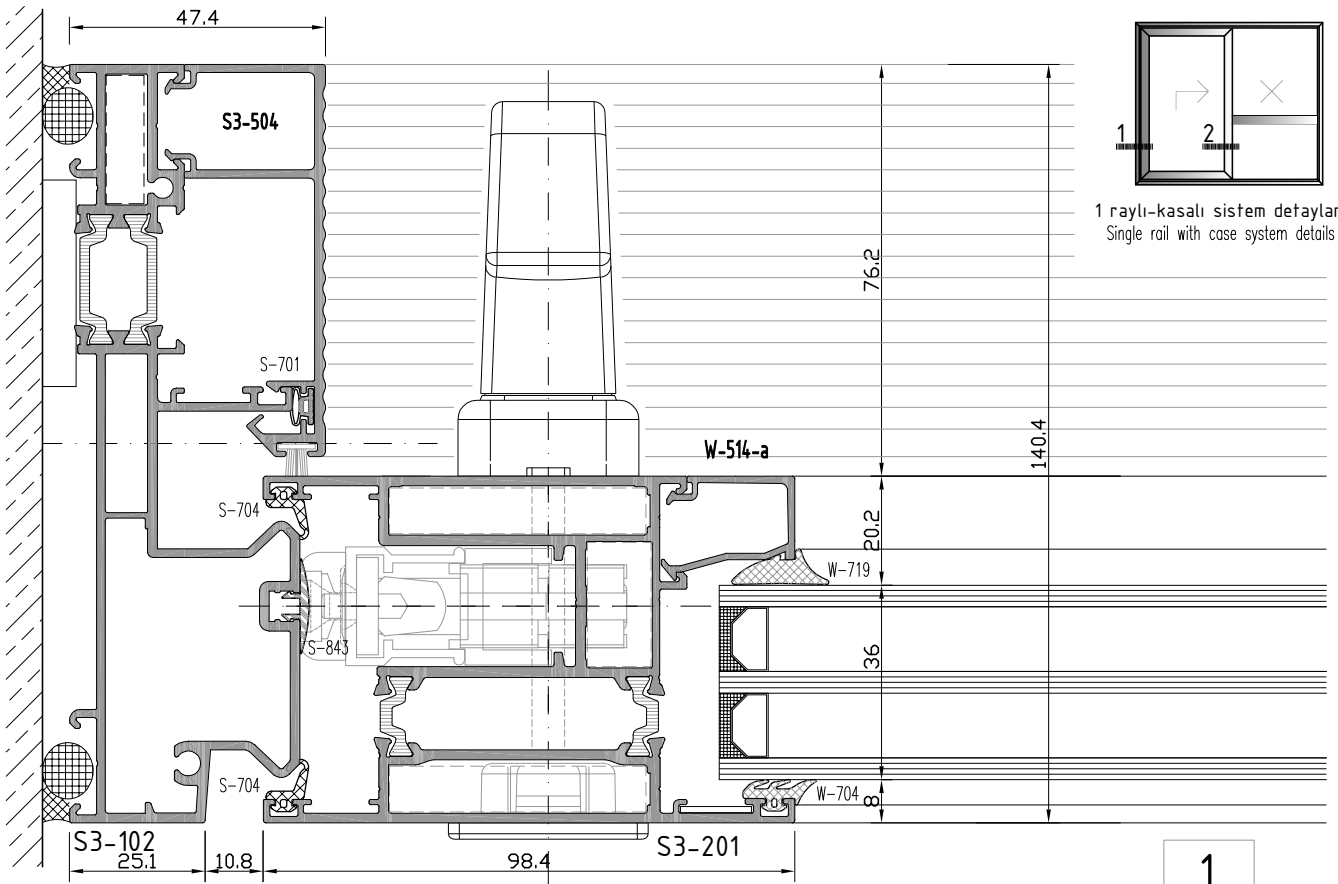

not to scale

S3

S 65-T YALITIMLI SÜRME SERİ

S65 -T INSULATED SLIDING SERIES

YAN BİTİM - ORTA KAYIT DETAYI
WALL CONNECTION - MULLION DETAIL

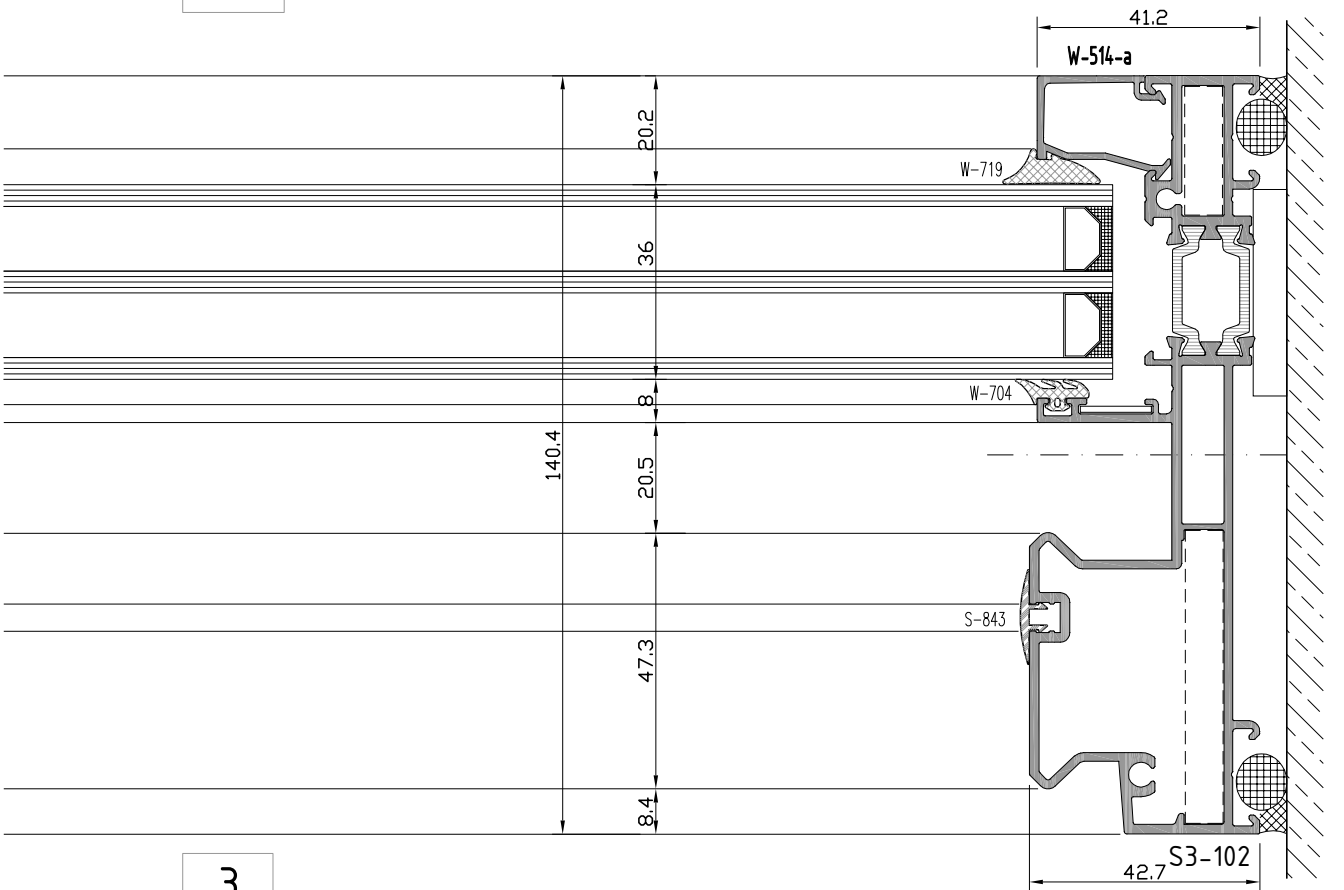
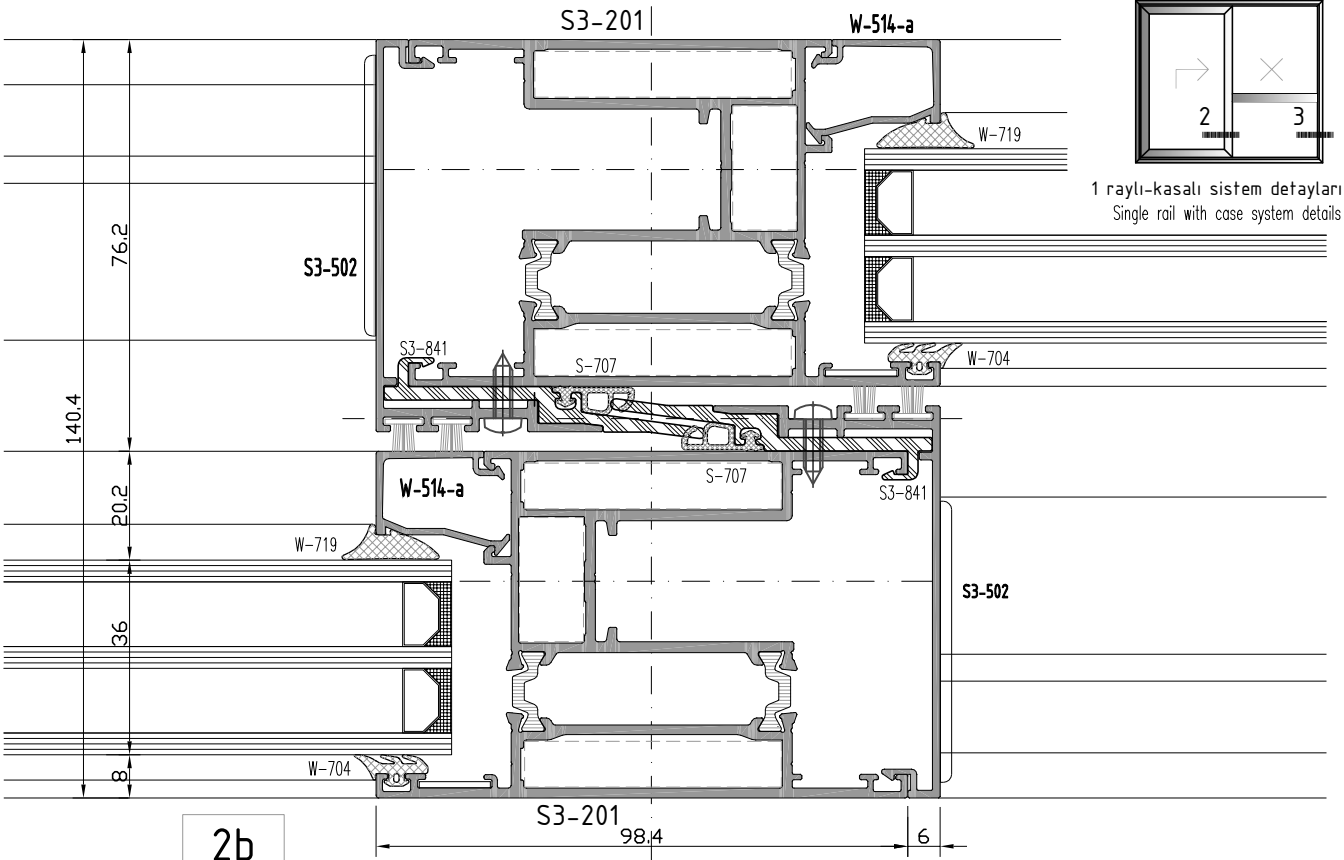

not to scale

S3

S 65-T YALITIMLI SÜRME SERİ

S65 -T INSULATED SLIDING SERIES

ÜST BİTİM - ALT BİTİM DETAYI
TOP EDGE - BOTTOM EDGE DETAIL

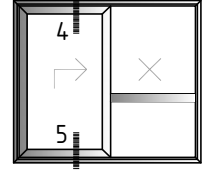
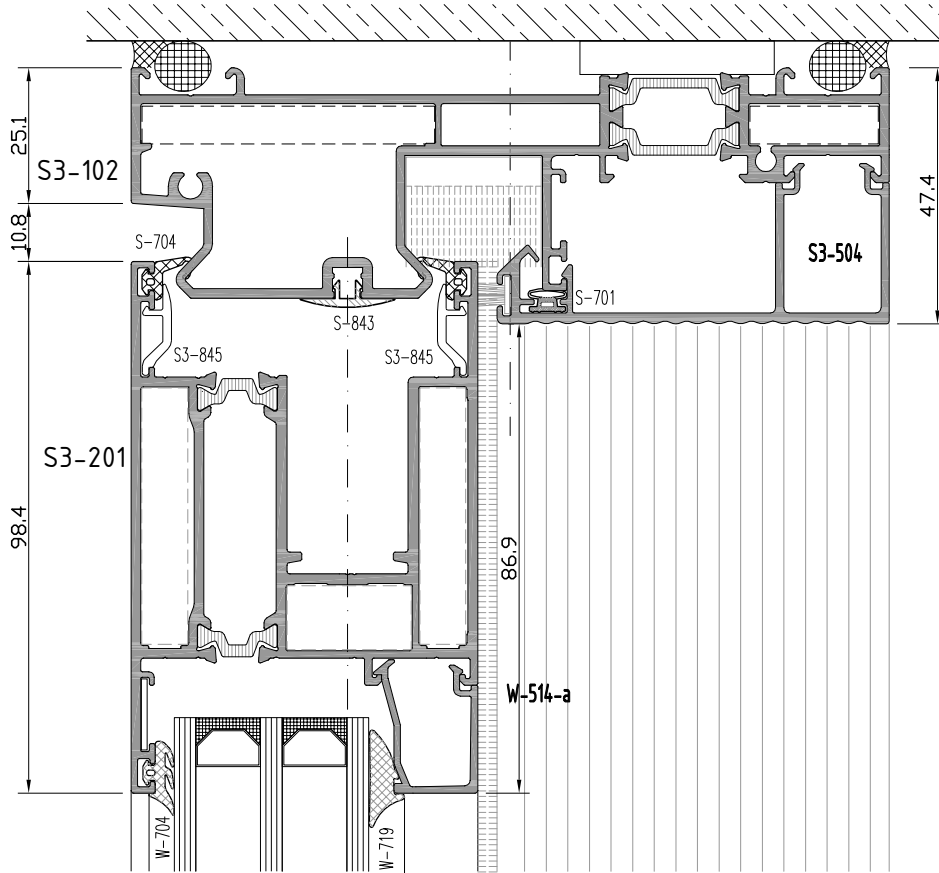

1 raylı-kasalı sistem detayları
Single rail with case system details

4

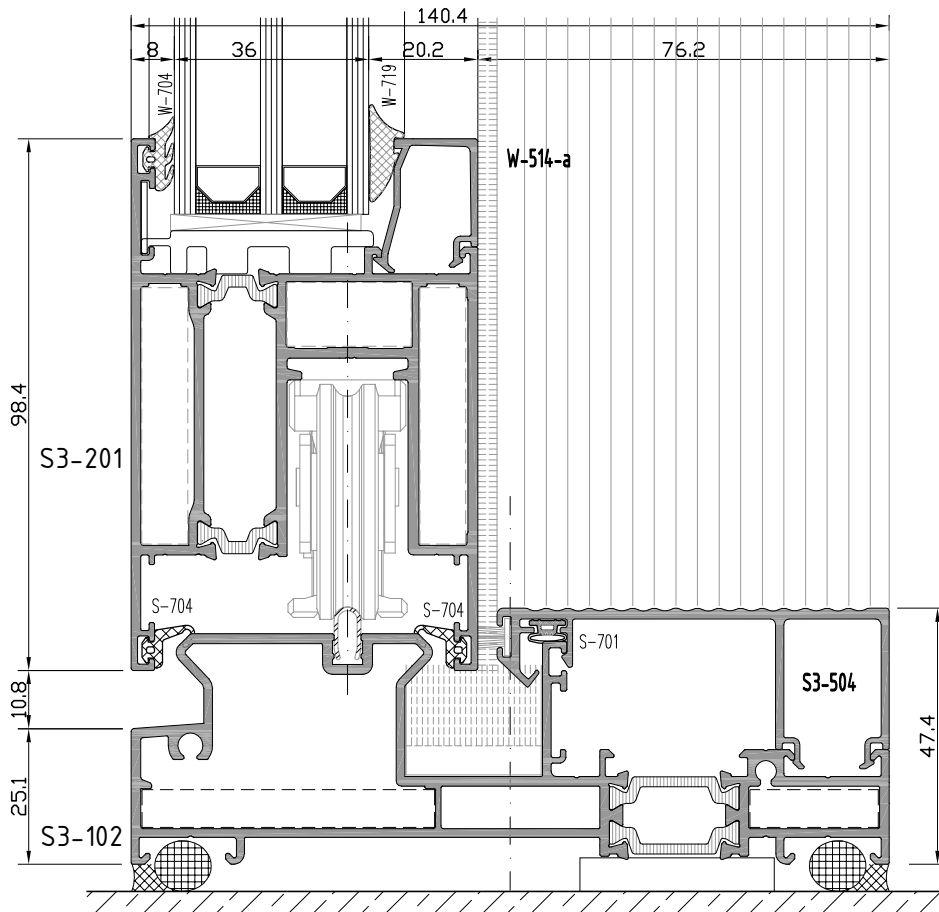

5

not to scale

S3

S 65-T YALITIMLI SÜRME SERİ

S65 -T INSULATED SLIDING SERIES

ÜST-ALT BİTİM - ORTA KAYIT DETAYI
TOP-BOTTOM EDGE - MULLION DETAIL

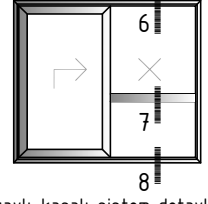
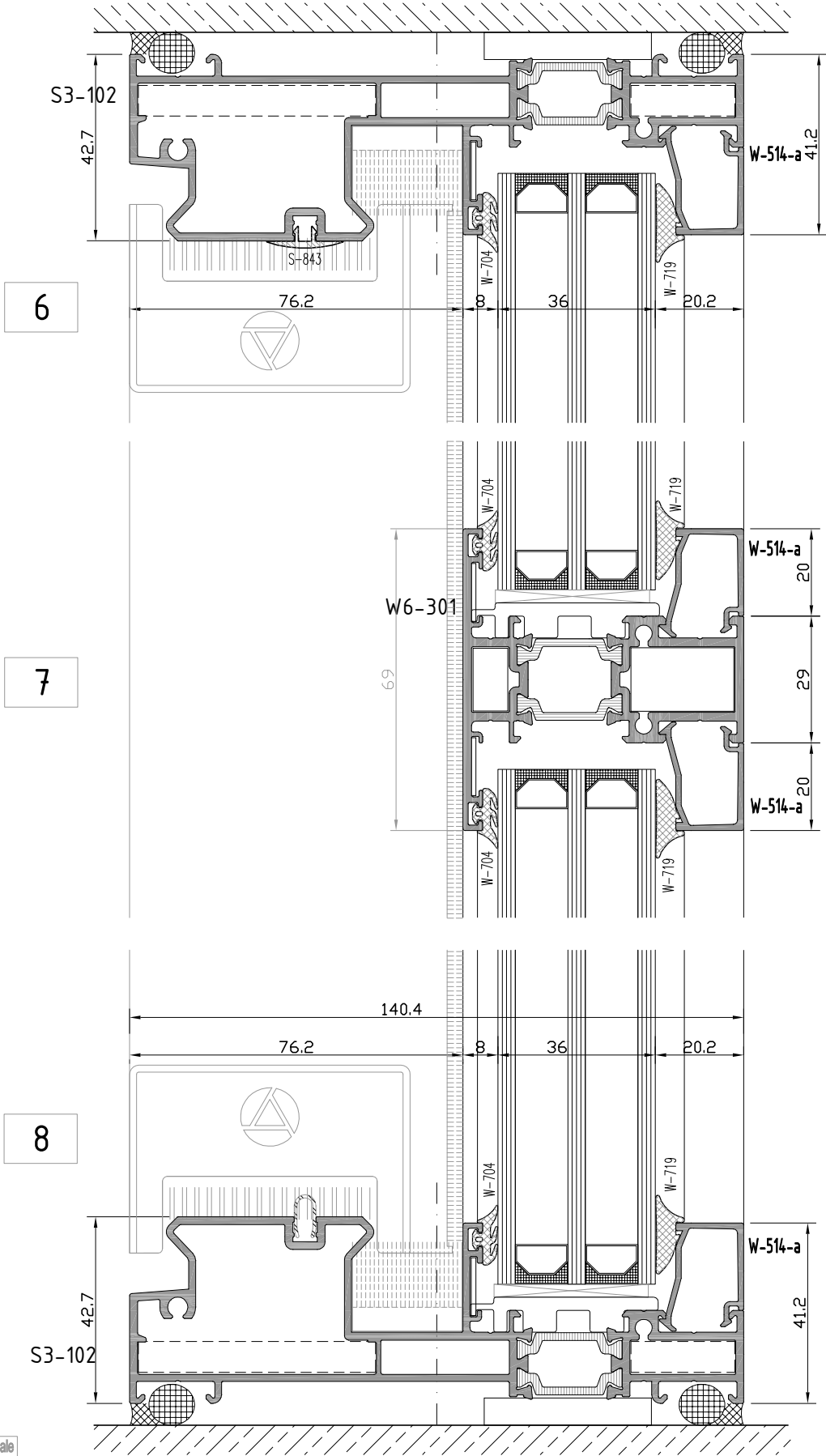

1 raylı-kasalı sistem detayları
Single rail with case system details

S3

S 65-T YALITIMLI SÜRME SERİ

S65 -T INSULATED SLIDING SERIES

YAN BİTİM DETAYI

WALL CONNECTION DETAIL

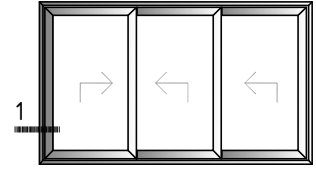

3 raylı sistem detayları
Triple rail system details

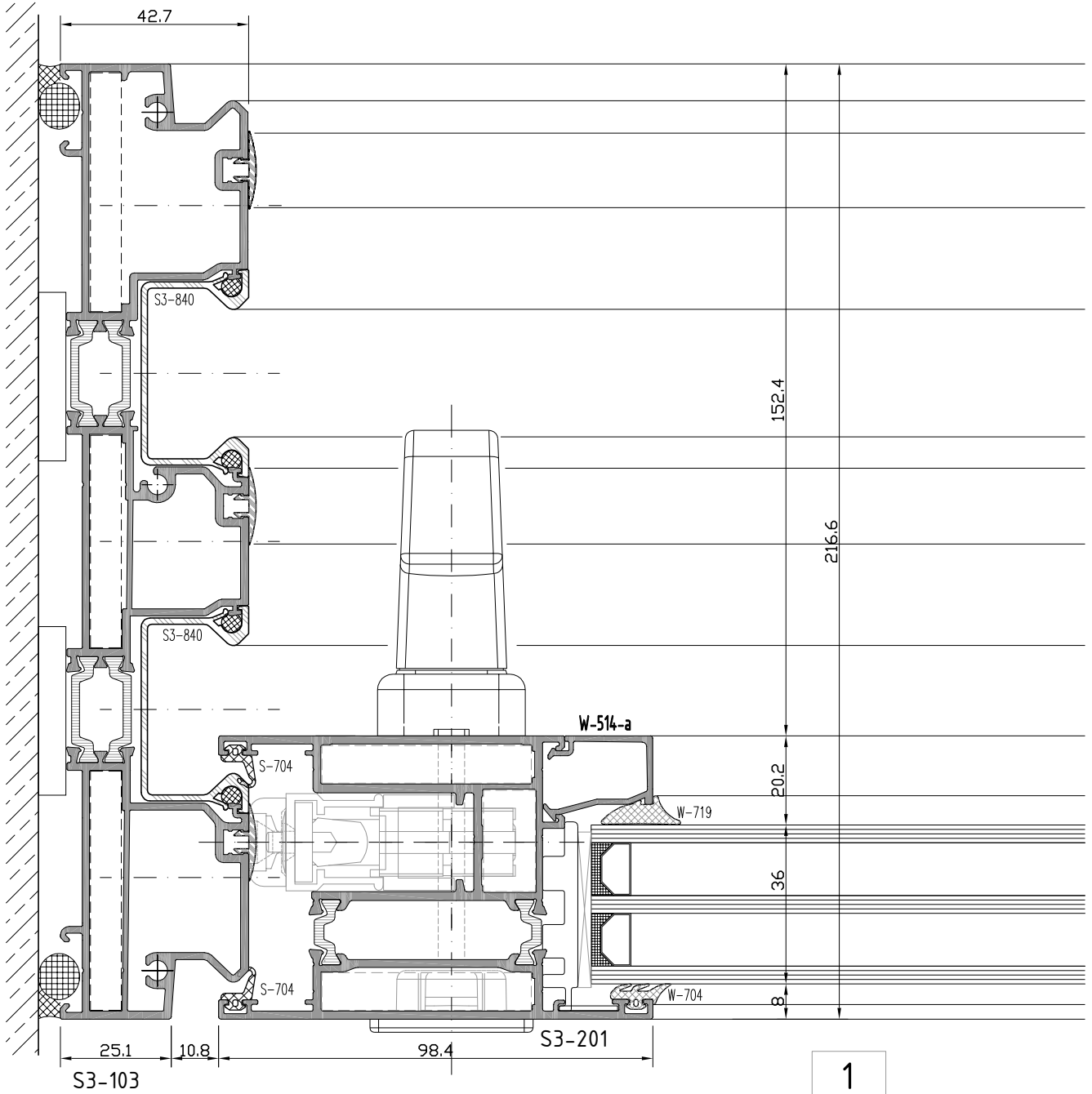

not to scale

S3

S 65-T YALITIMLI SÜRME SERİ

S65 -T INSULATED SLIDING SERIES

ORTA KAYIT DETAYI

MULLION DETAIL

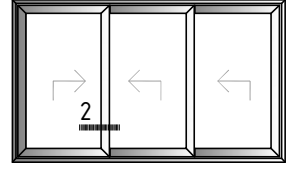

3 raylı sistem detayları
Triple rail system details

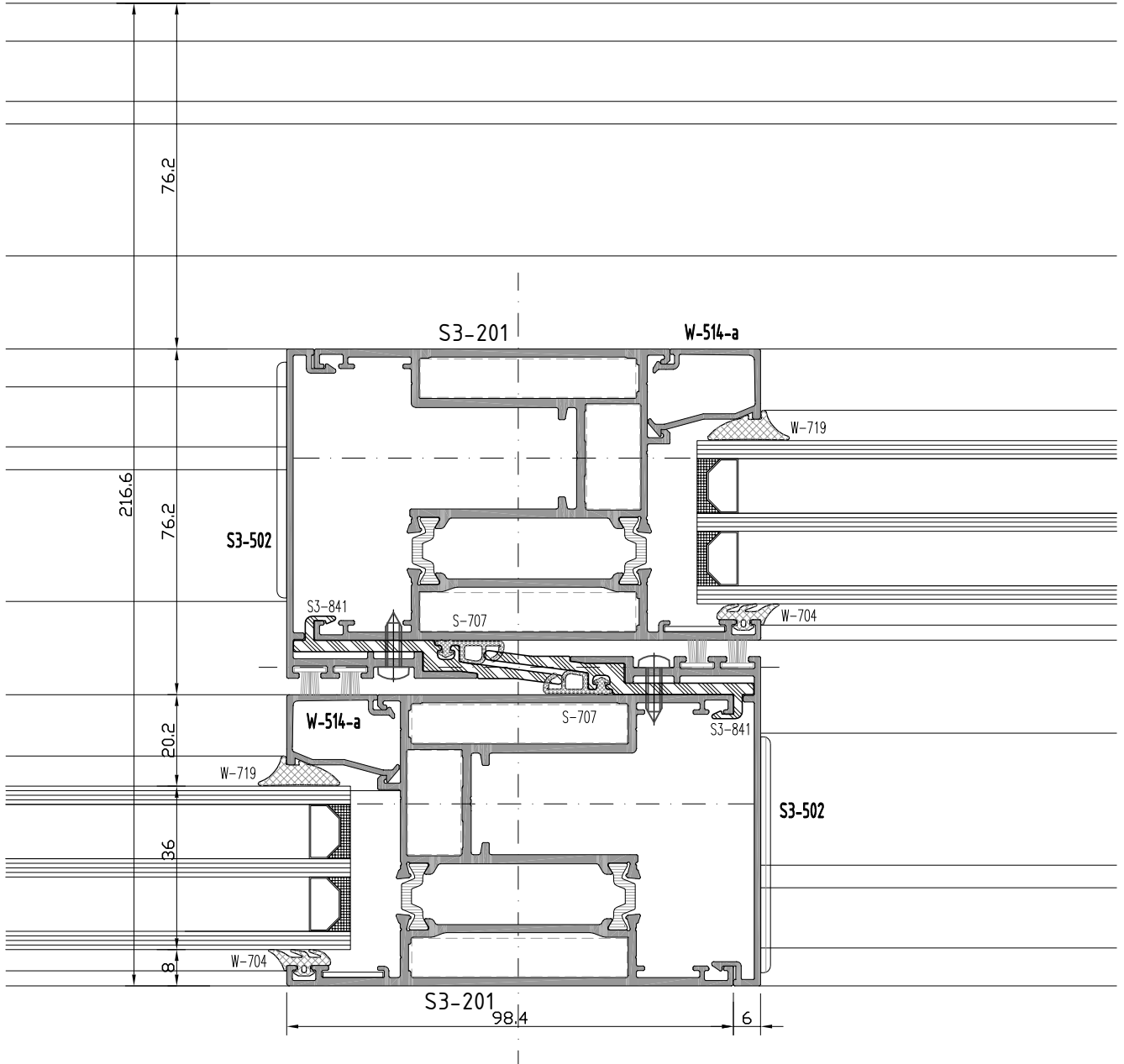

2

not to scale

S3

S 65-T YALITIMLI SÜRME SERİ

S65 -T INSULATED SLIDING SERIES

ORTA KAYIT DETAYI

MULLION DETAIL

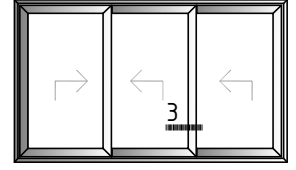

3 raylı sistem detayları
Triple rail system details

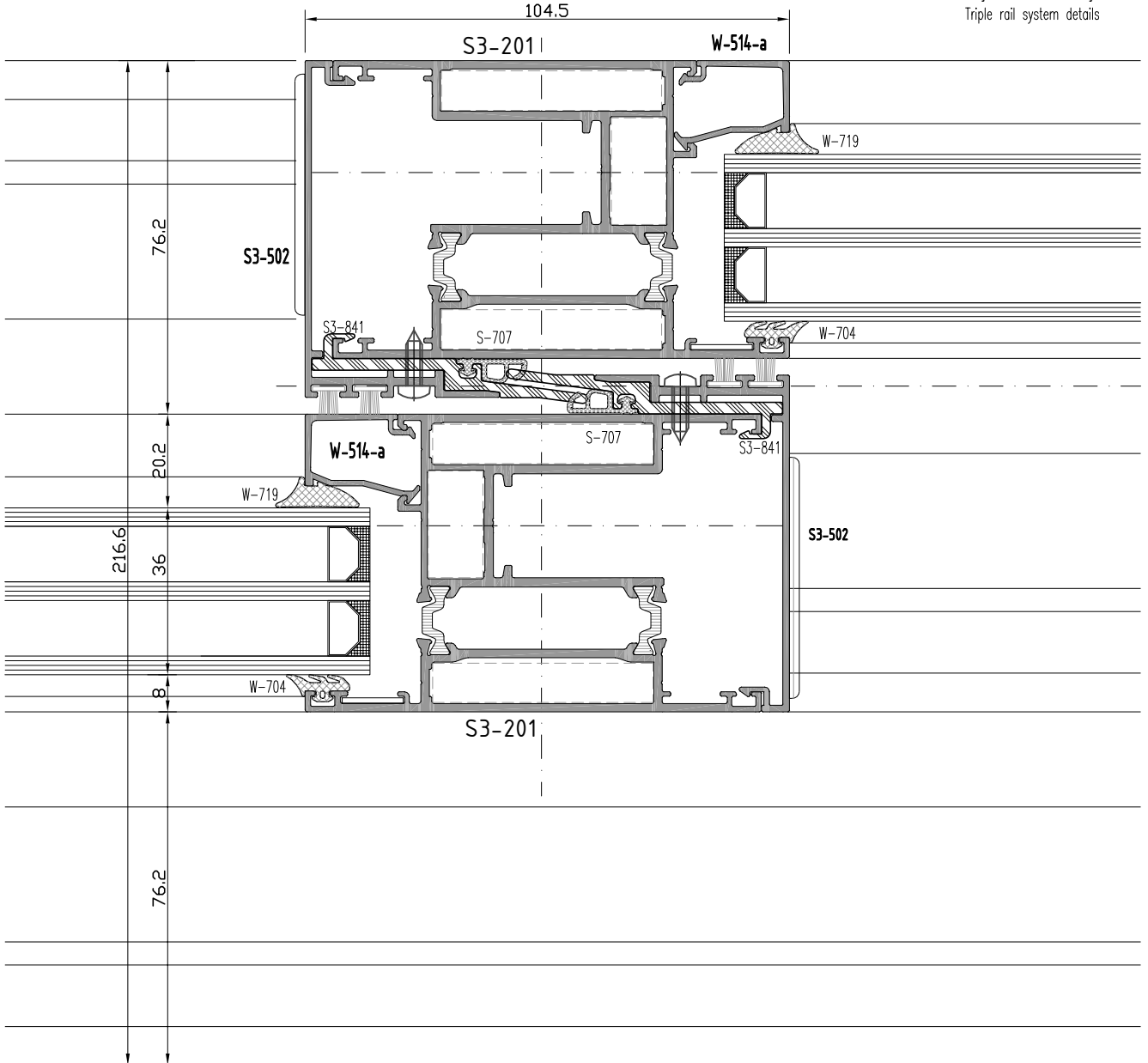

3

not to scale

S3

S 65-T YALITIMLI SÜRME SERİ

S65 -T INSULATED SLIDING SERIES

YAN BİTİM DETAYI

WALL CONNECTION DETAIL

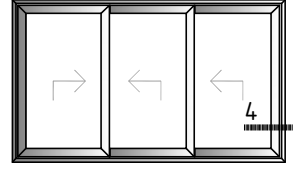

3 raylı sistem detayları
Triple rail system details

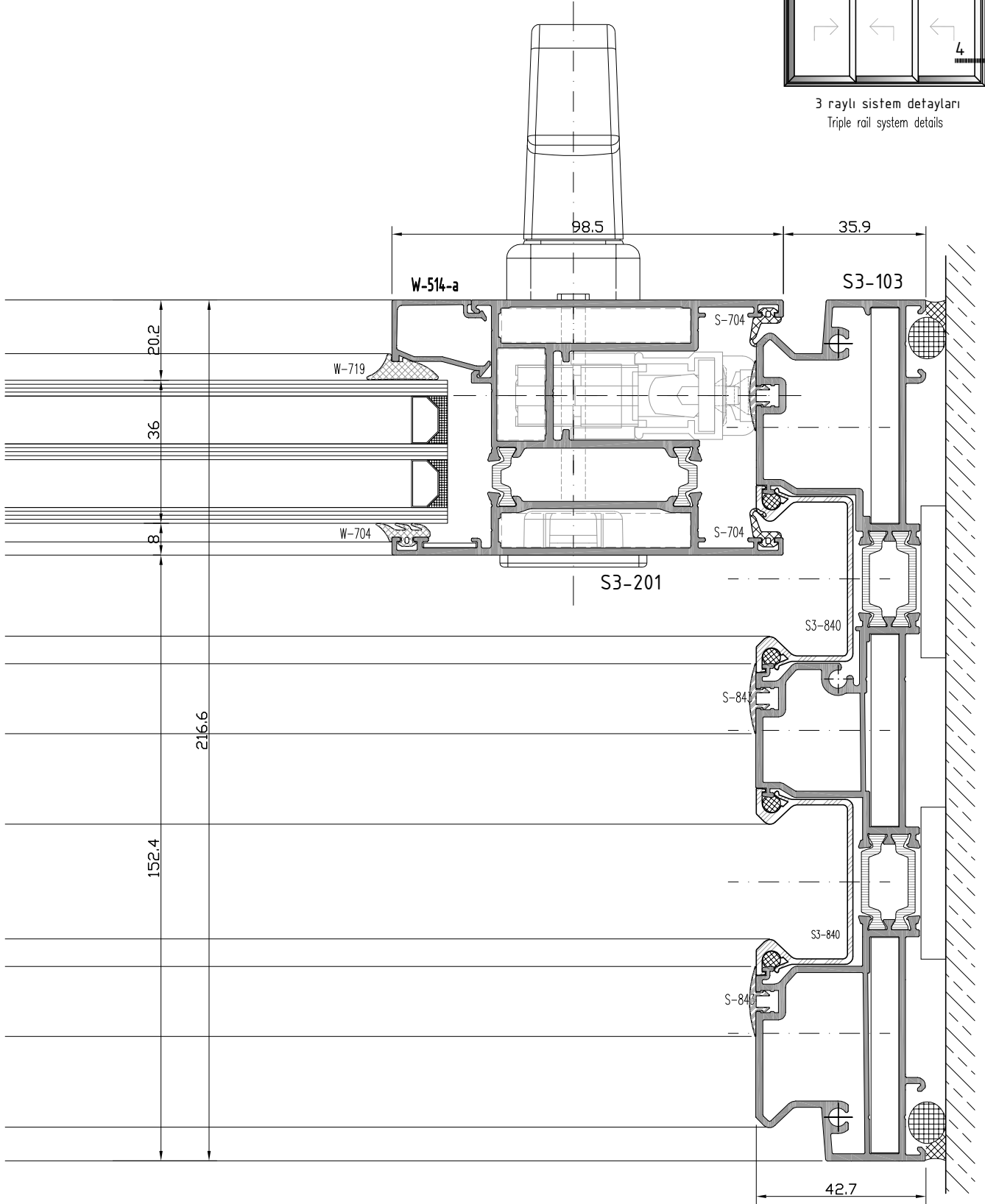

4

not to scale

S3

S 65-T YALITIMLI SÜRME SERİ

S65 -T INSULATED SLIDING SERIES

ÜST BİTİM - ALT BİTİM DETAYI

TOP EDGE - BOTTOM EDGE DETAIL

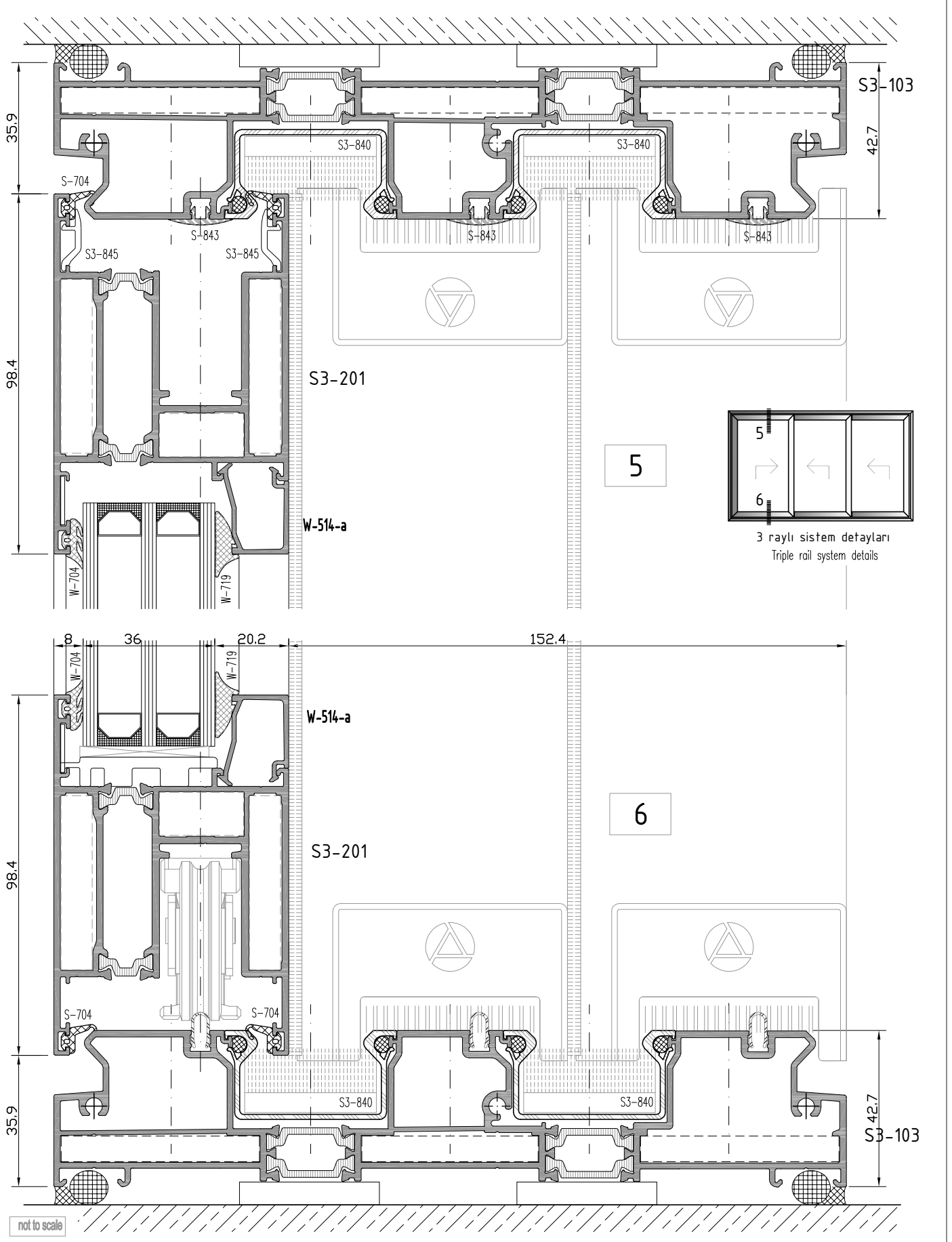

S3

S 65-T YALITIMLI SÜRME SERİ

S65 -T INSULATED SLIDING SERIES

ÜST BİTİM - ALT BİTİM DETAYI

TOP EDGE - BOTTOM EDGE DETAIL

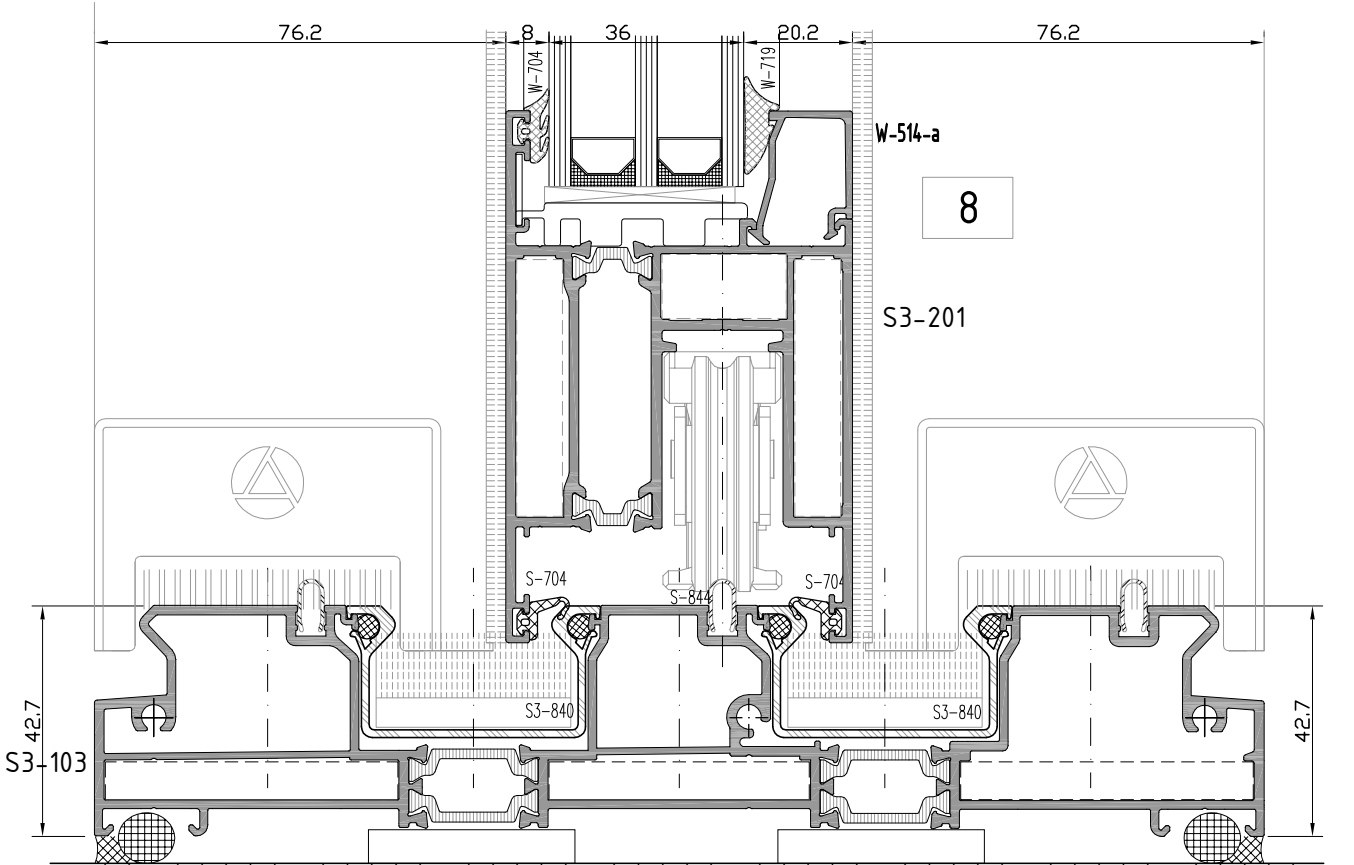
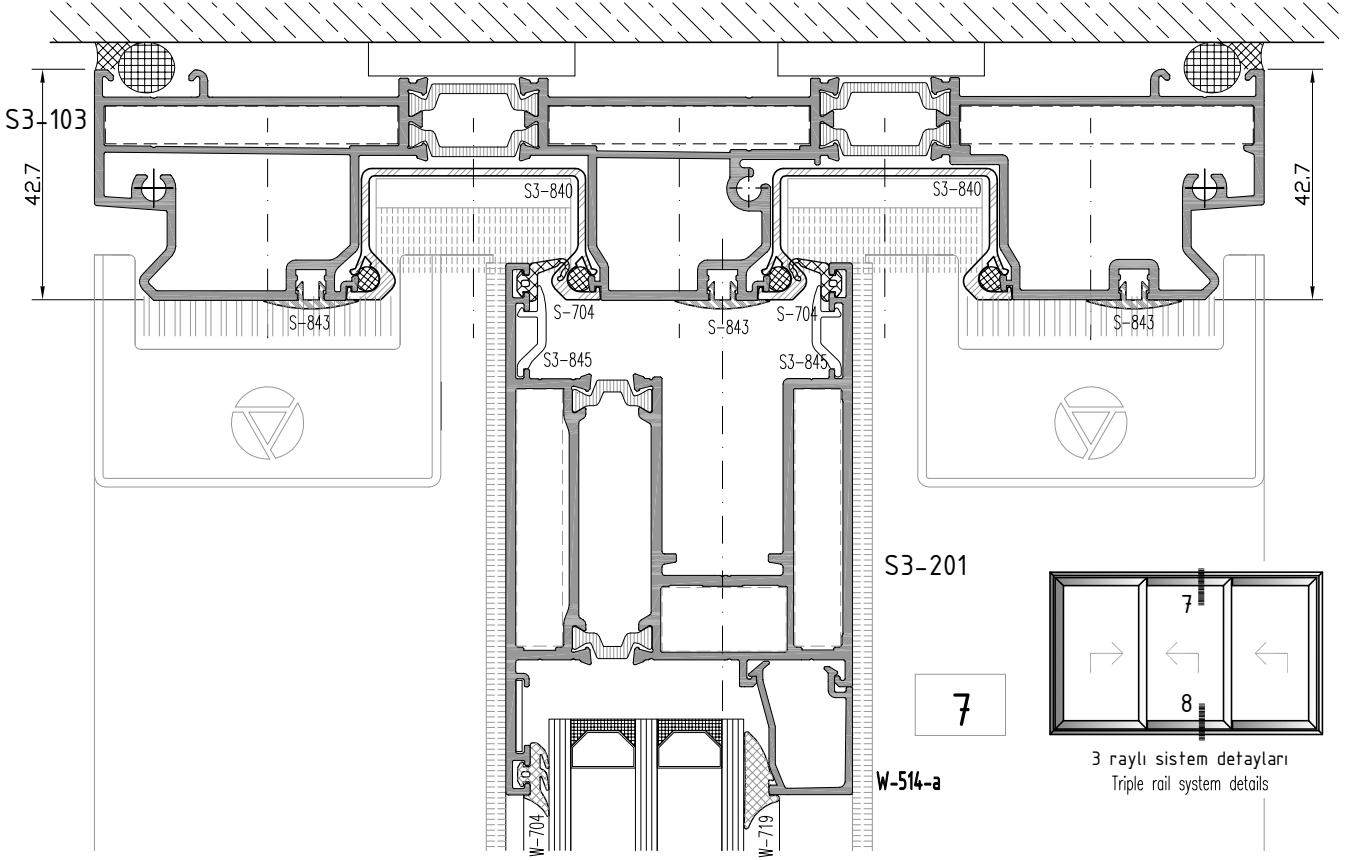

not to scale

S3

S 65-T YALITIMLI SÜRME SERİSİ

S65 -T INSULATED SLIDING SERIES

ÜST BİTİM - ALT BİTİM DETAYI

TOP EDGE - BOTTOM EDGE DETAIL

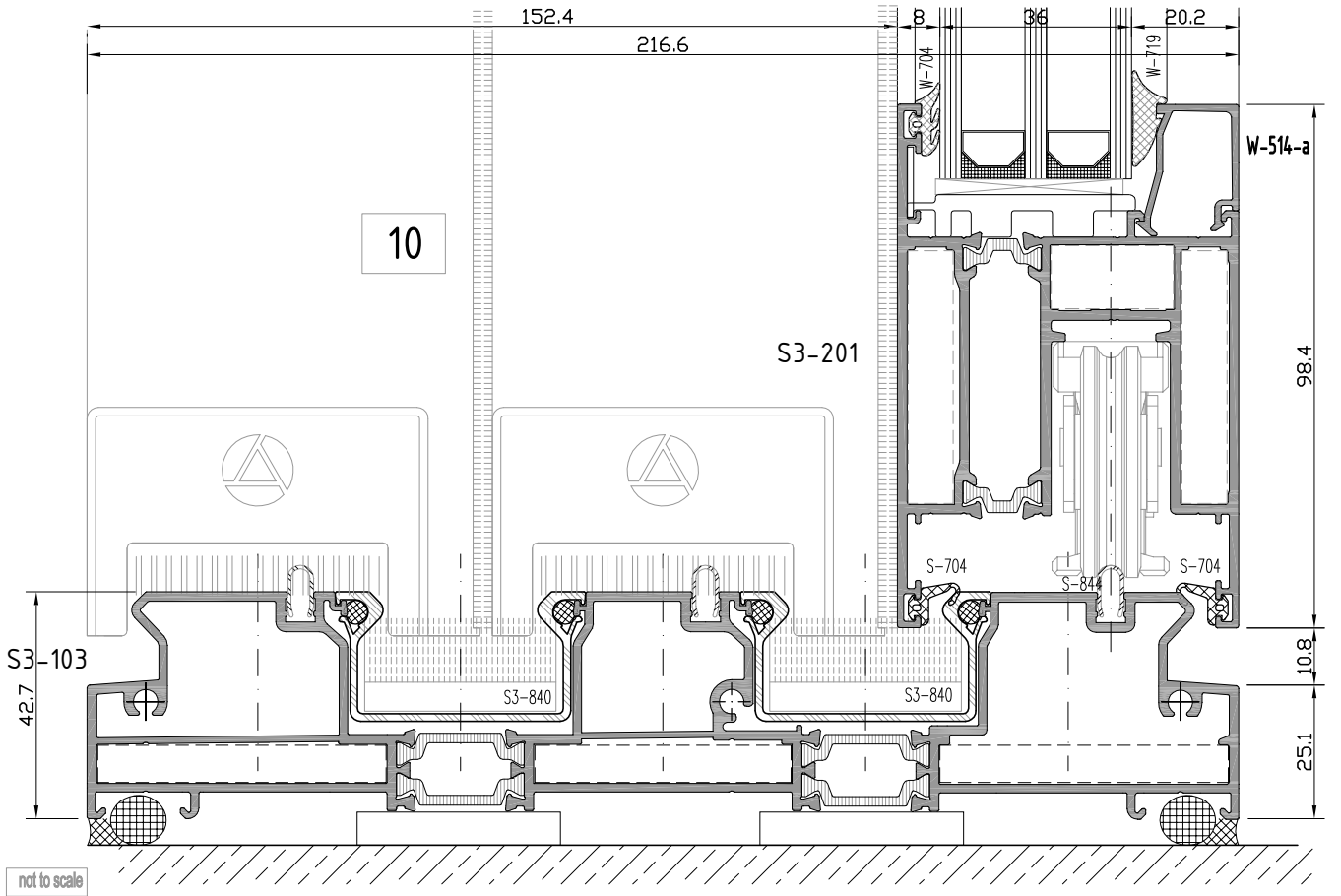
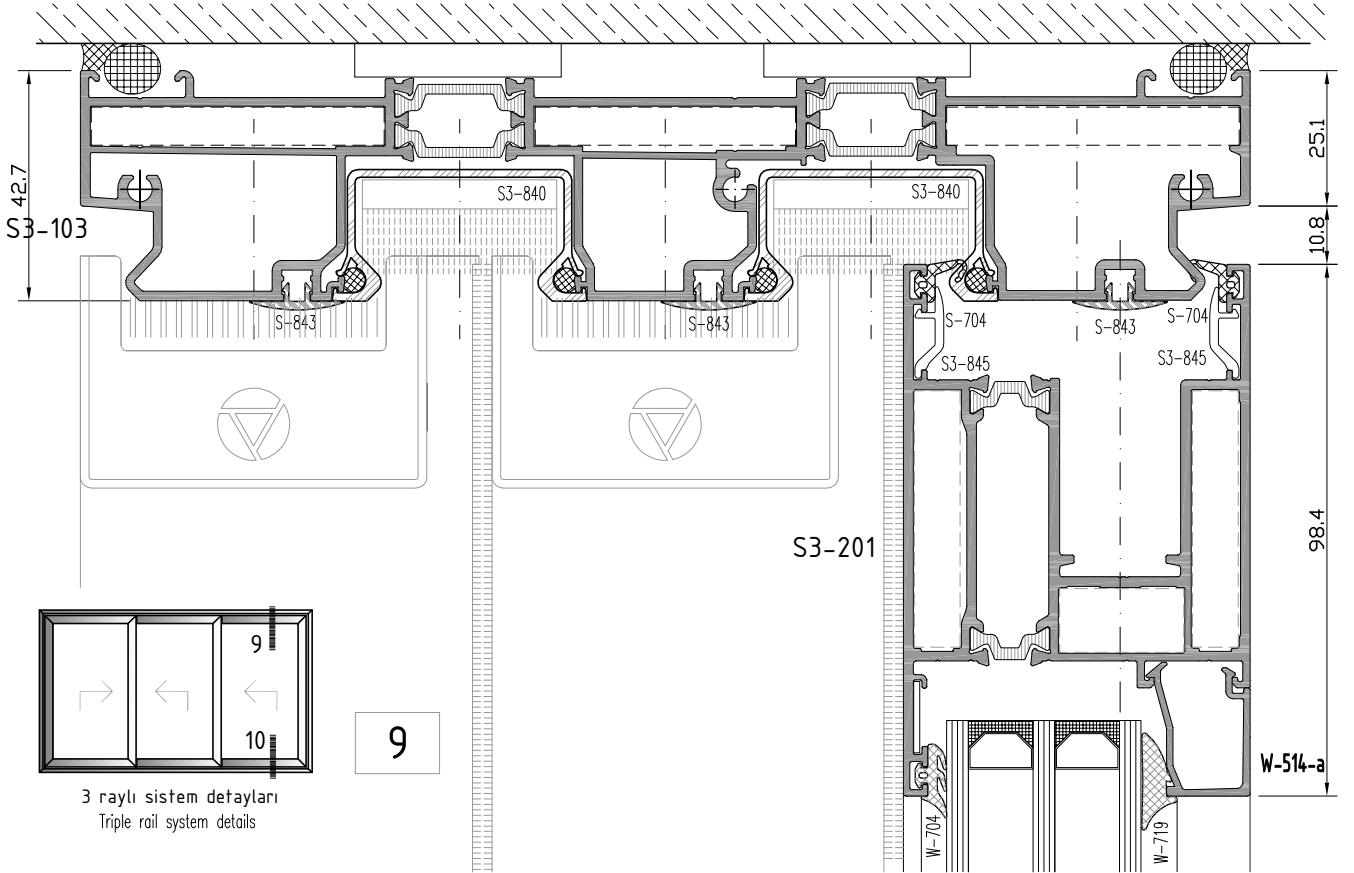

S3

S 65-T YALITIMLI SÜRME SERİ

S65 -T INSULATED SLIDING SERIES

YAN BİTİM DETAYI

WALL CONNECTION DETAIL

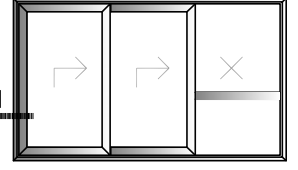

2 raylı-kasalı sistem detayları
Double rail with case system details

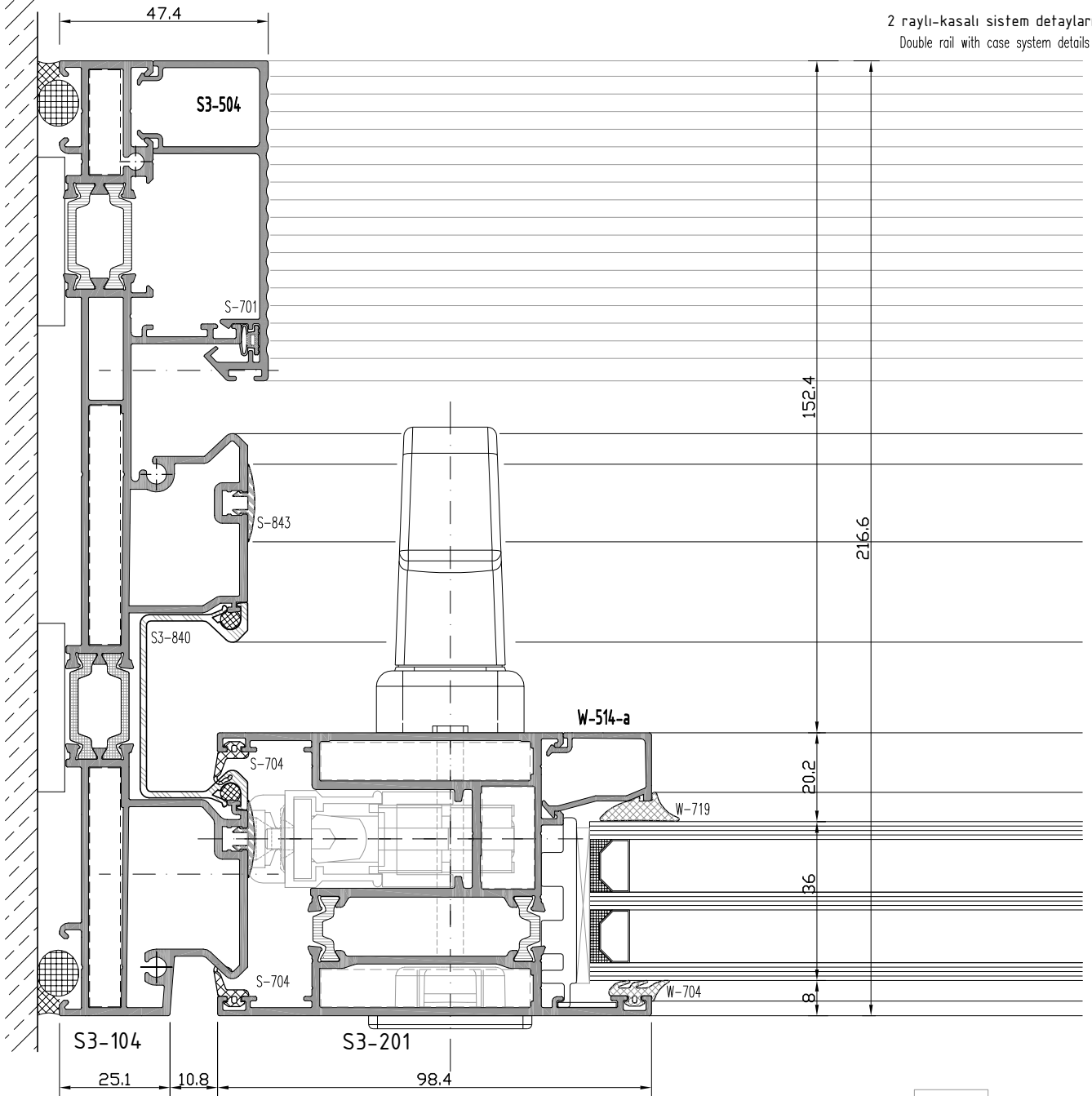

1

S3

S 65-T YALITIMLI SÜRME SERİ

S65 -T INSULATED SLIDING SERIES

ORTA KAYIT DETAYI

MULLION DETAIL

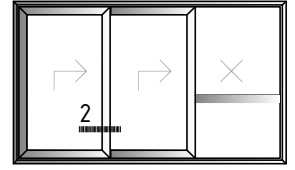

2 raylı-kasalı sistem detayları
Double rail with case system details

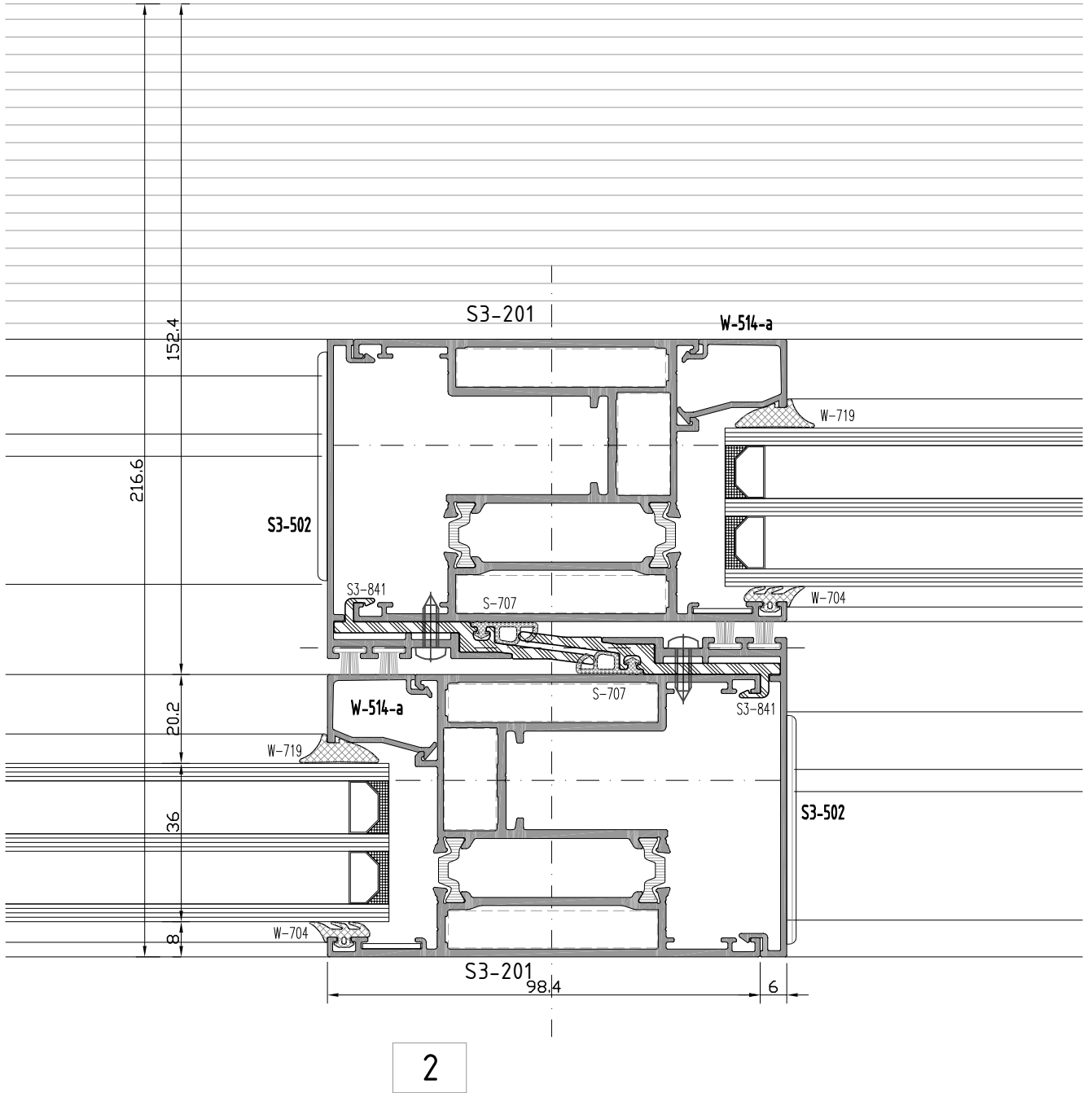

S3

S 65-T YALITIMLI SÜRME SERİ

S65 -T INSULATED SLIDING SERIES

ORTA KAYIT DETAYI

MULLION DETAIL

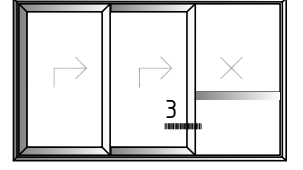

2 raylı-kasalı sistem detayları
Double rail with case system details

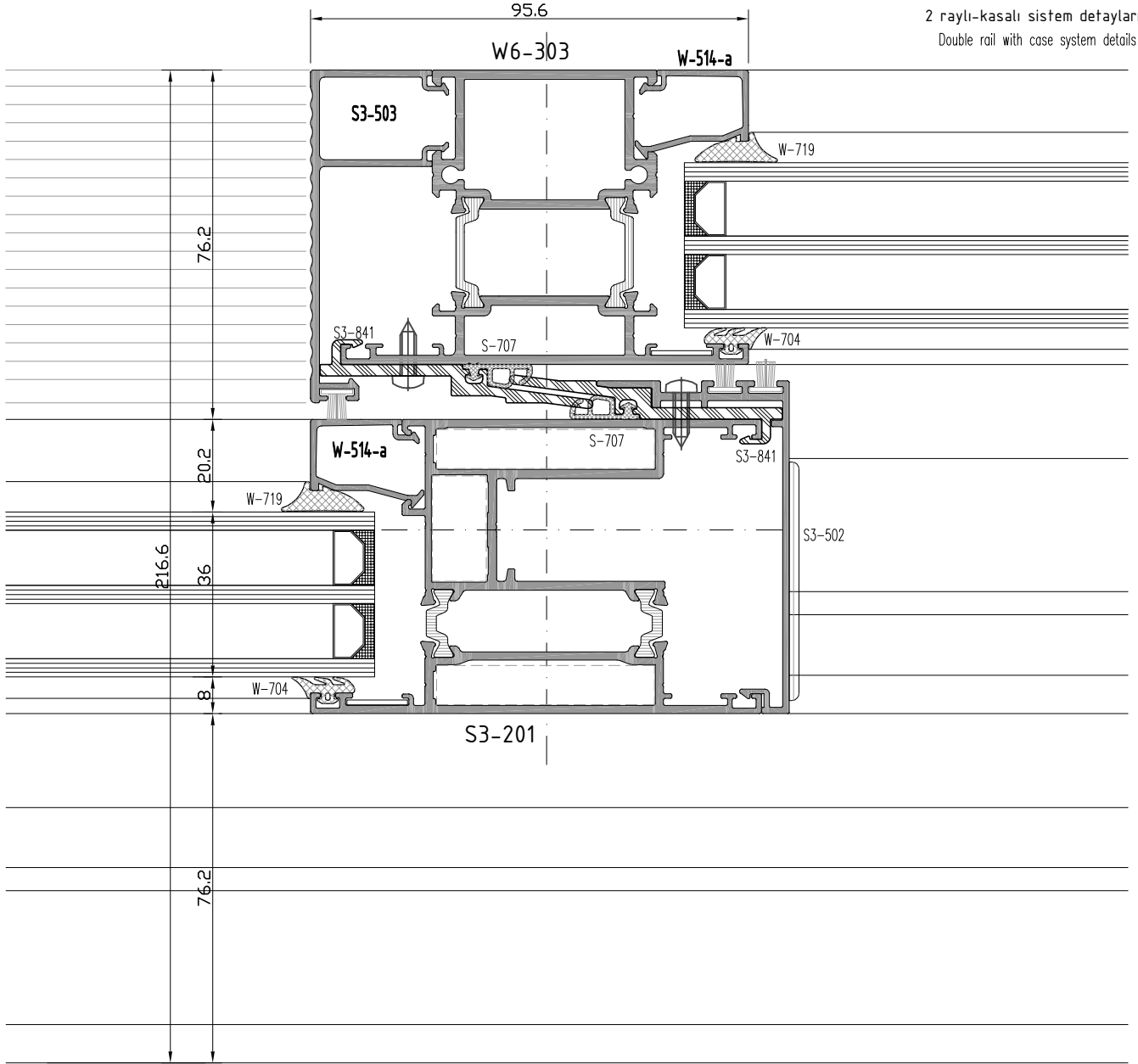

3a

not to scale

S3

S 65-T YALITIMLI SÜRME SERİ

S65 -T INSULATED SLIDING SERIES

ORTA KAYIT DETAYI

MULLION DETAIL

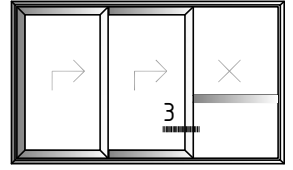

2 raylı-kasalı sistem detayları
Double rail with case system details

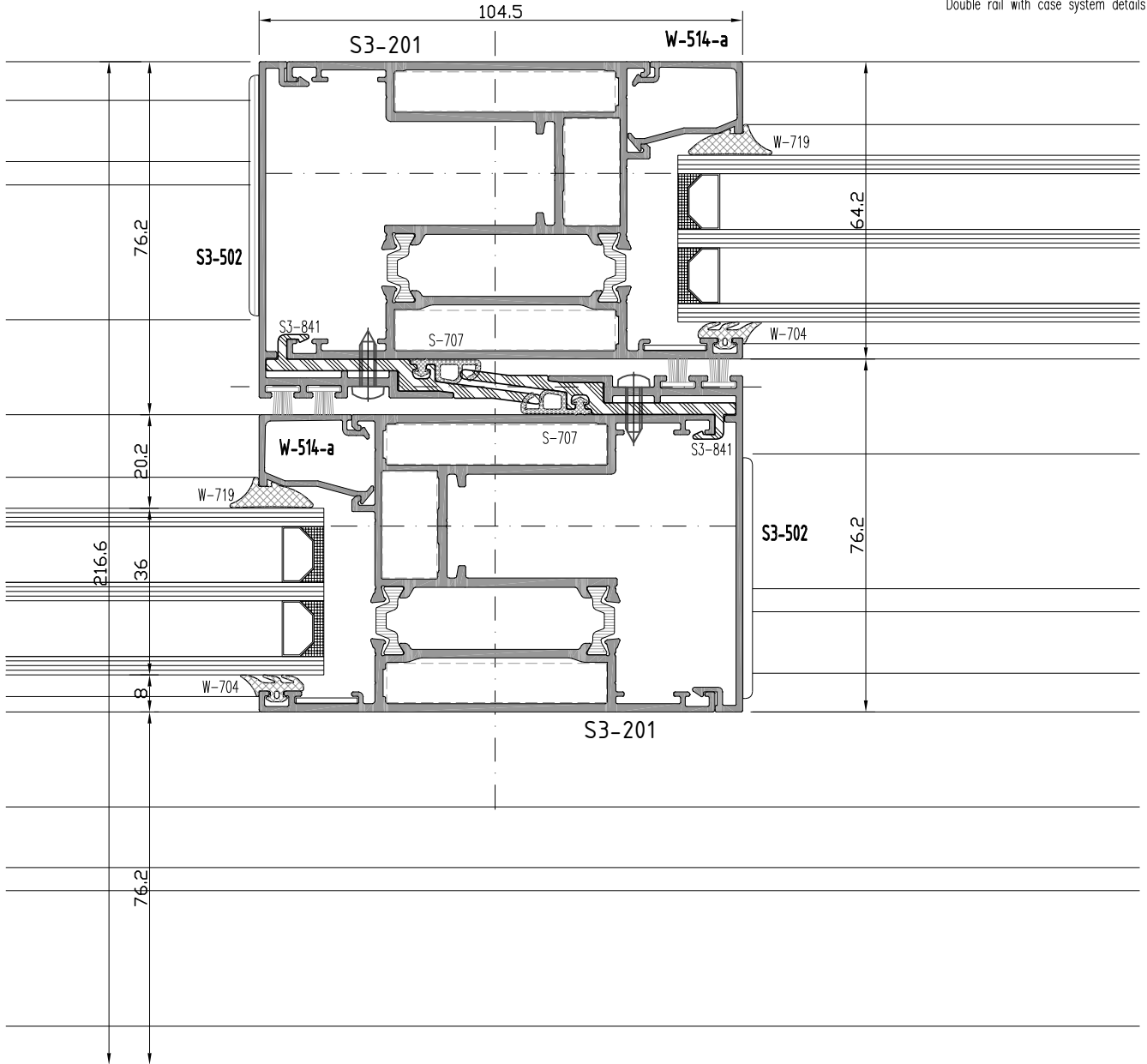

3b

not to scale

S3

S 65-T YALITIMLI SÜRME SERİ
S65 -T INSULATED SLIDING SERIES

YAN BİTİM DETAYI
WALL CONNECTION DETAIL

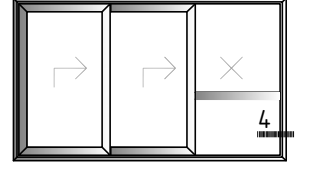

2 raylı-kasalı sistem detayları
Double rail with case system details

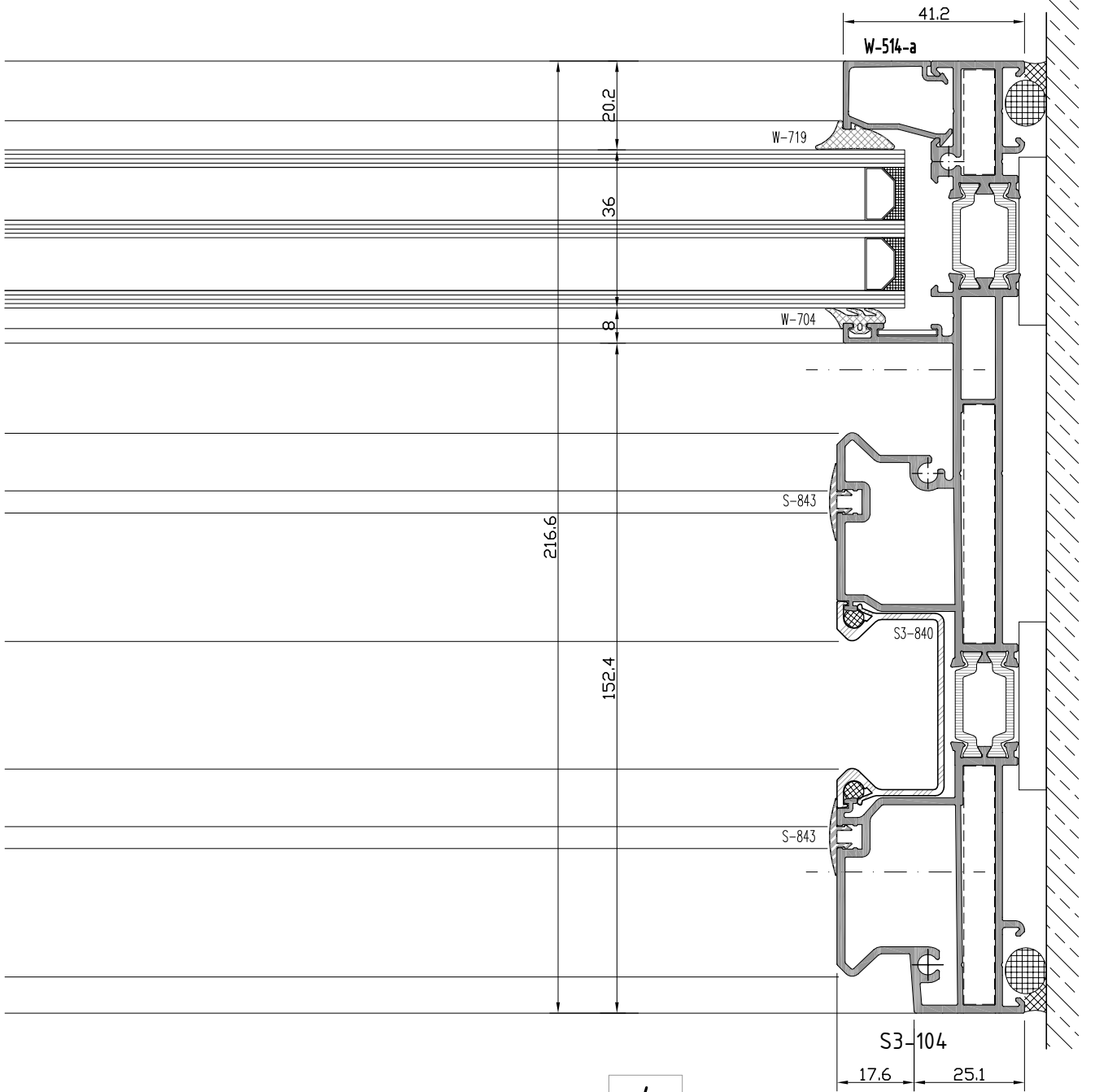

not to scale

S3

S 65-T YALITIMLI SÜRME SERİ

S65 -T INSULATED SLIDING SERIES

ÜST BİTİM - ALT BİTİM DETAYI

TOP EDGE - BOTTOM EDGE DETAIL

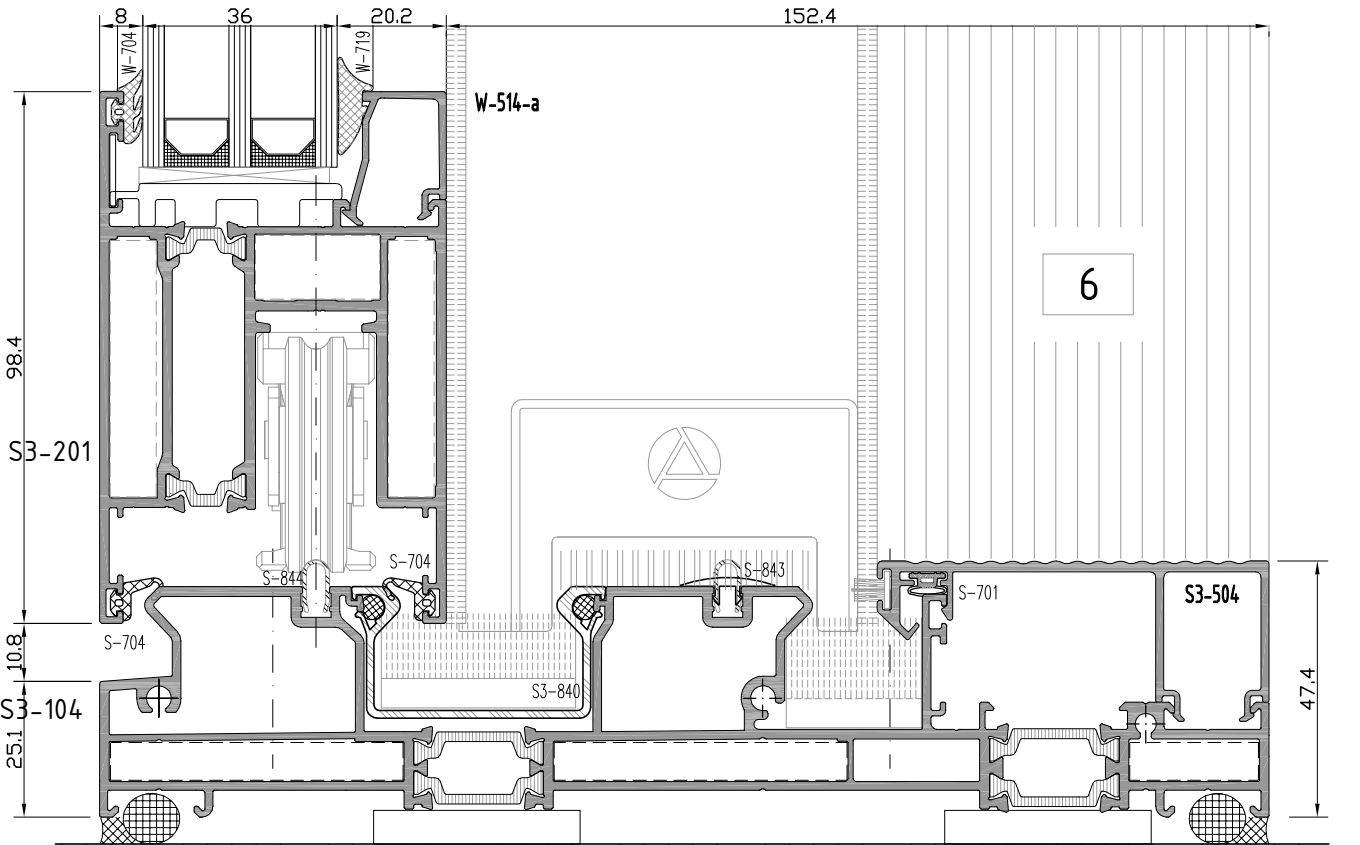
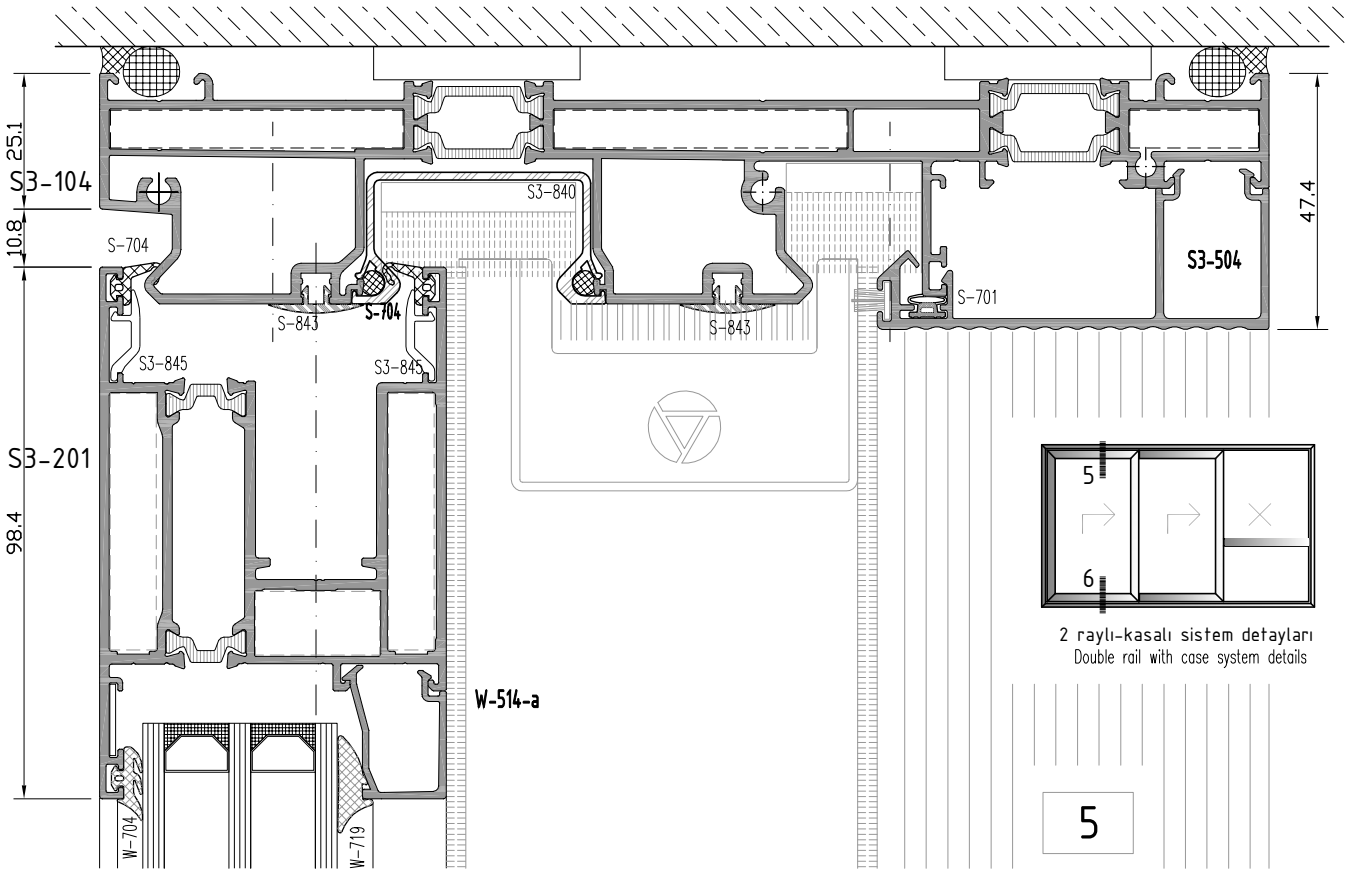

not to scale

S3

S 65-T YALITIMLI SÜRME SERİ

S65 -T INSULATED SLIDING SERIES

ÜST BİTİM - ALT BİTİM DETAYI

TOP EDGE - BOTTOM EDGE DETAIL

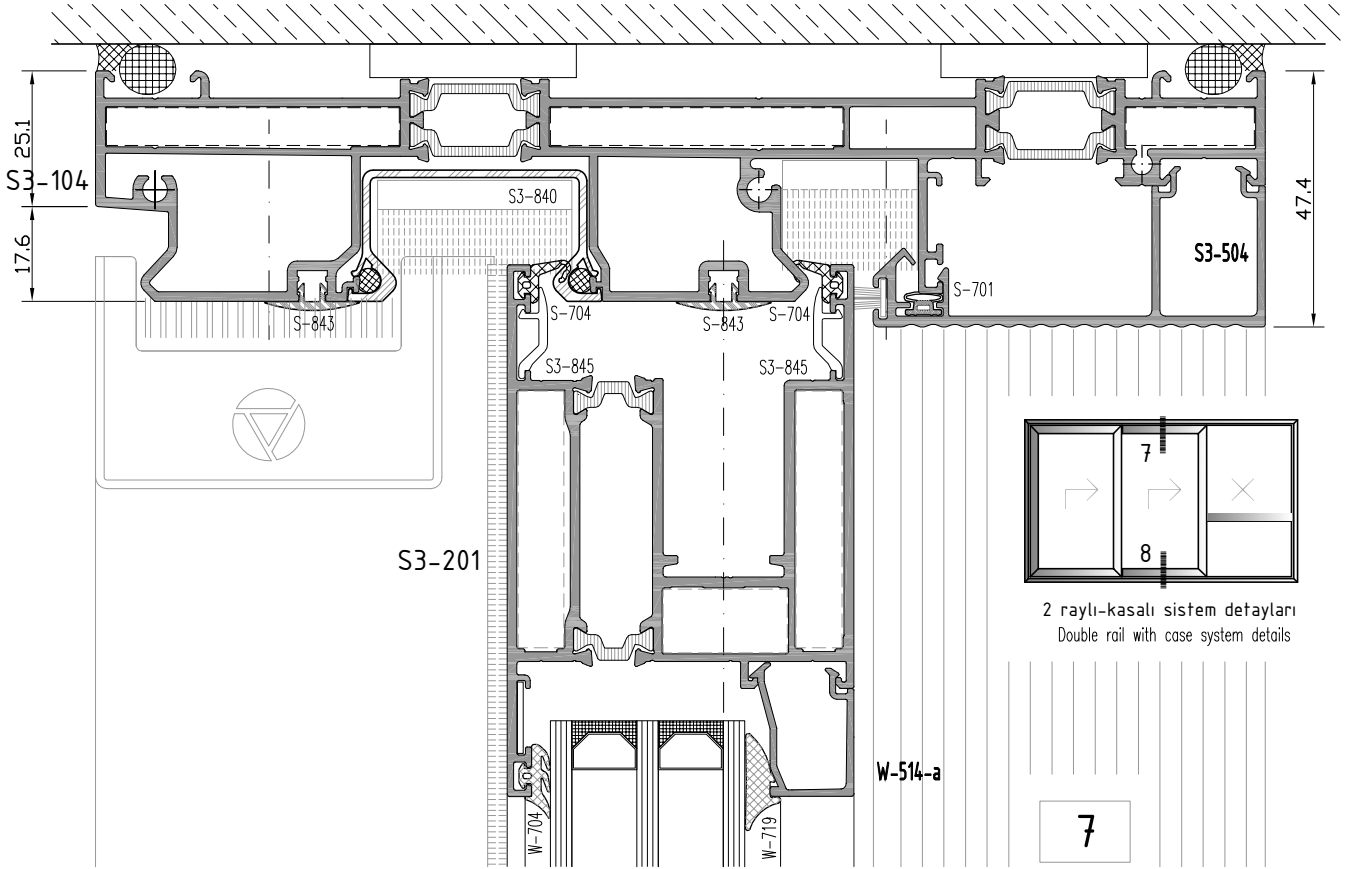

2 raylı-kasalı sistem detayları
Double rail with case system details

7

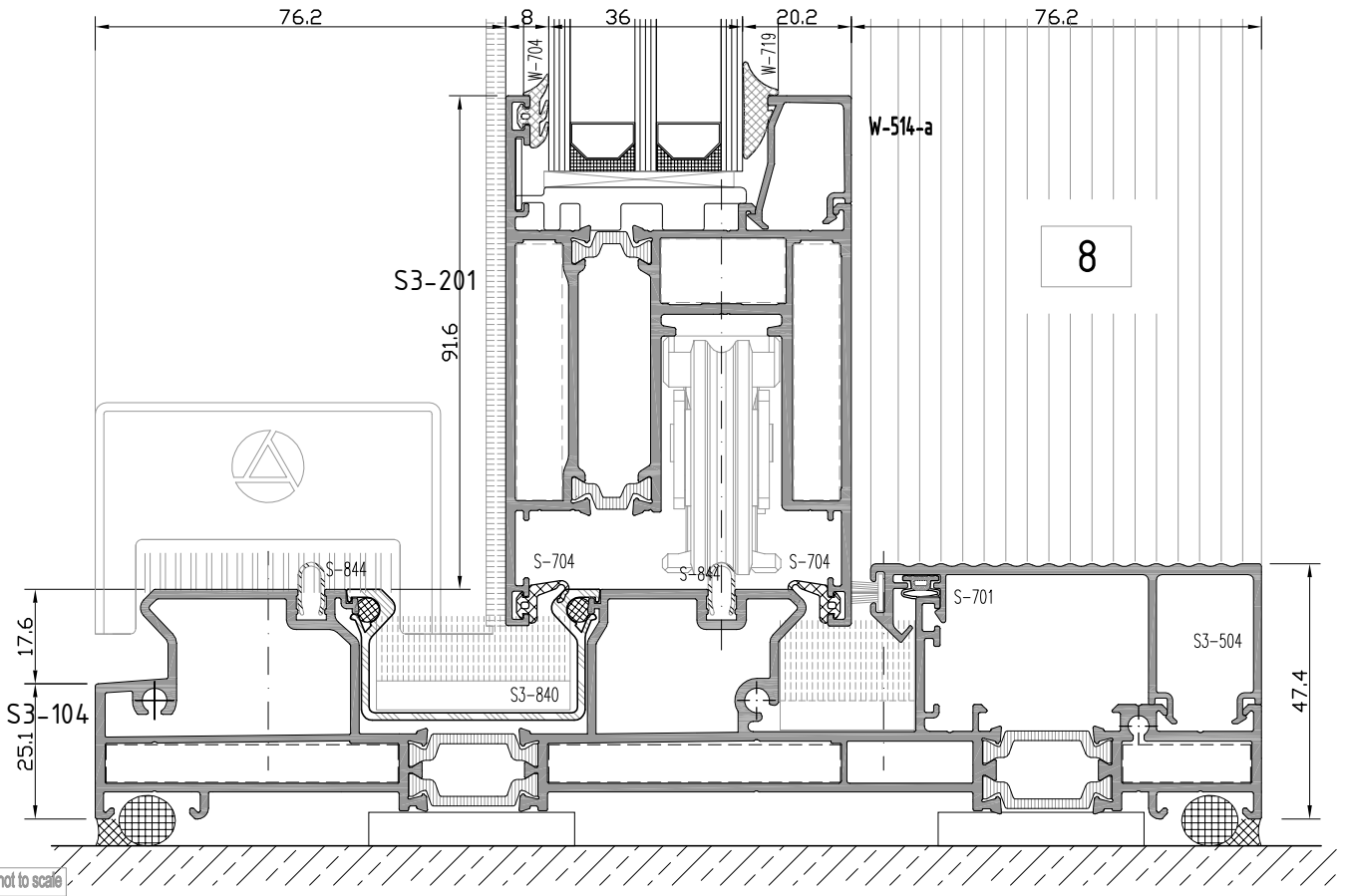

8

not to scale

S3

S 65-T YALITIMLI SÜRME SERİ

S65 -T INSULATED SLIDING SERIES

ÜST-ALT BİTİM - ORTA KAYIT DETAYI
TOP-BOTTOM EDGE - MULLION DETAIL

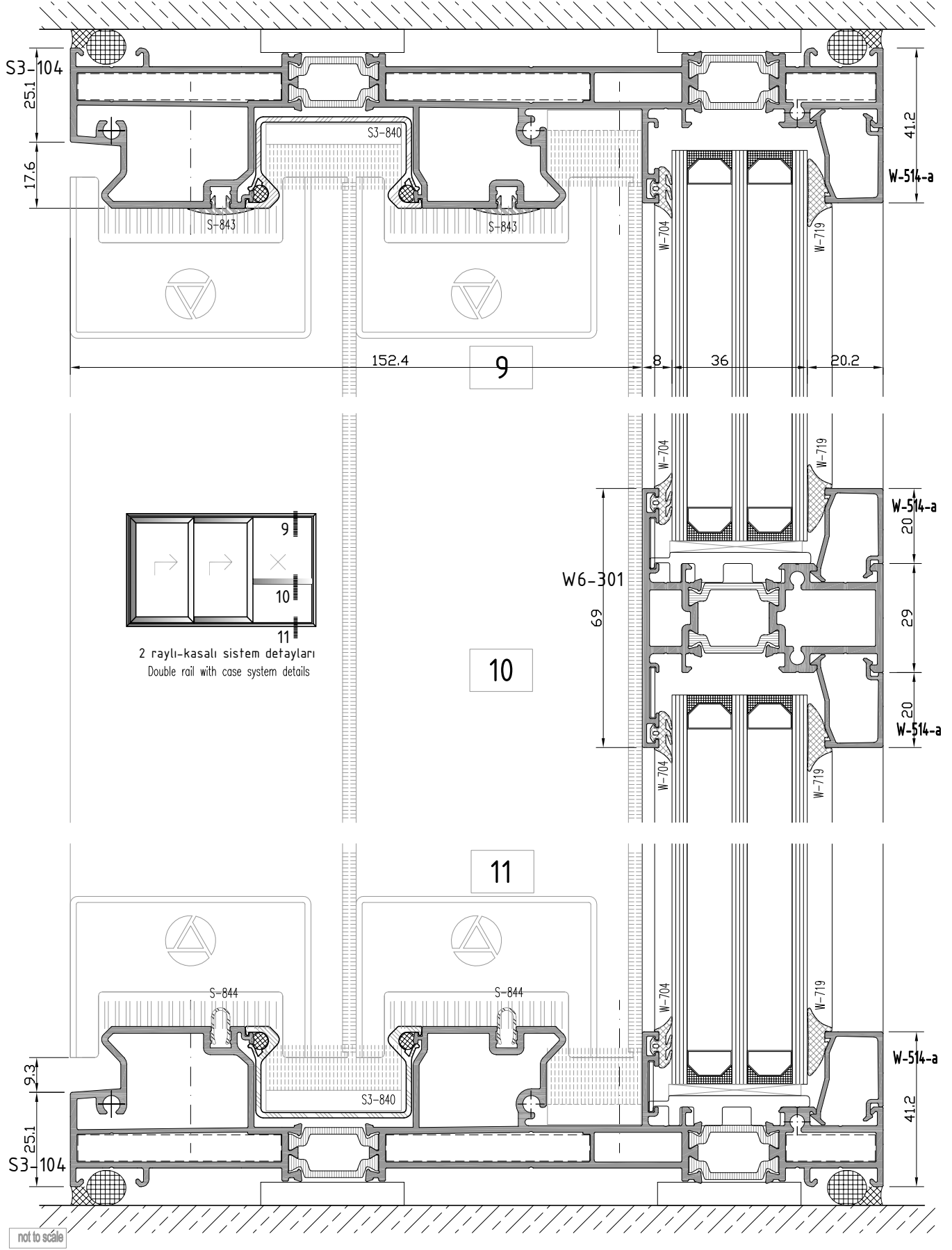

S3

S 65-T YALITIMLI SÜRME SERİ

S65 -T INSULATED SLIDING SERIES

ÜST BİTİM - ORTA KAYIT DETAYI

TOP EDGE - MULLION DETAIL

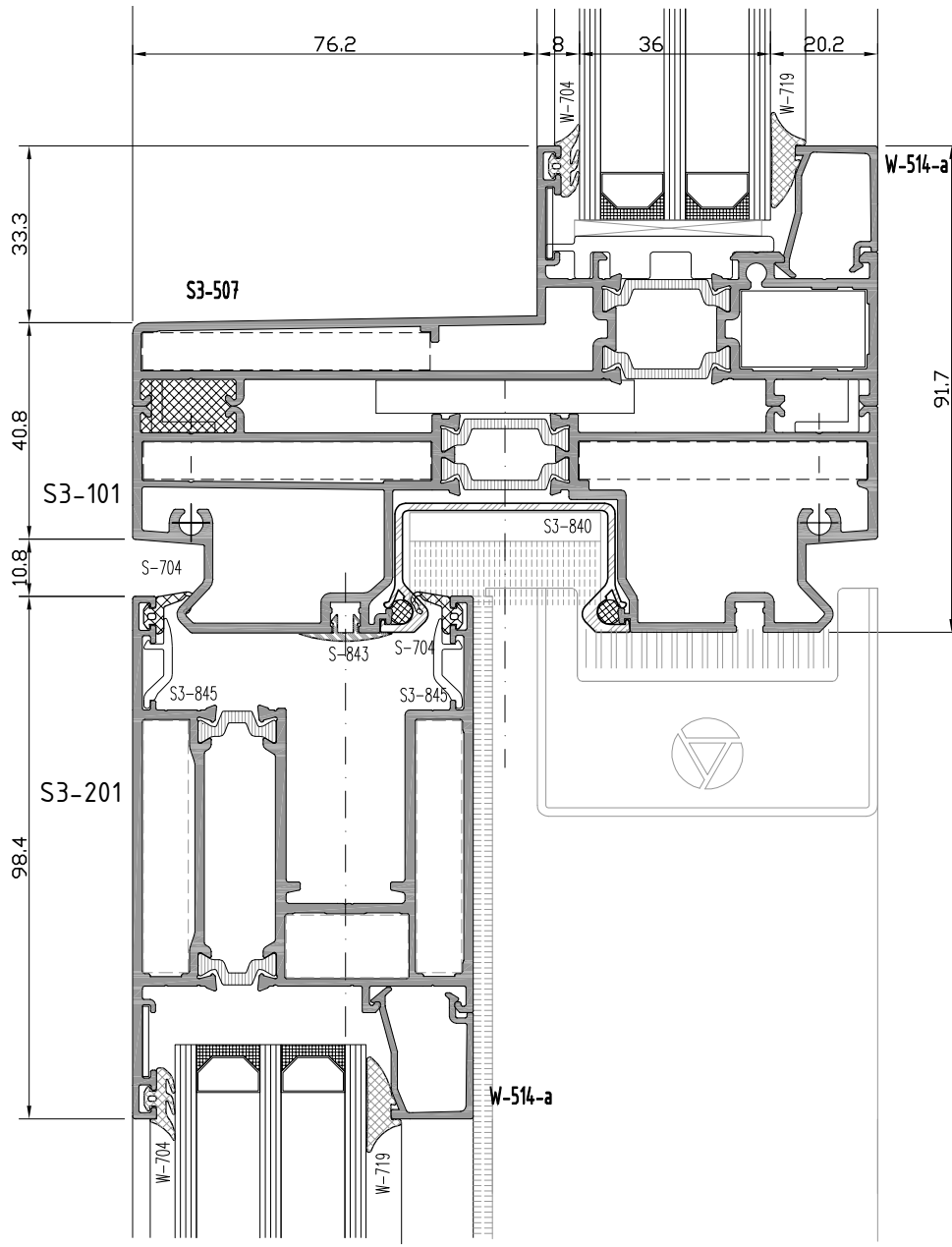
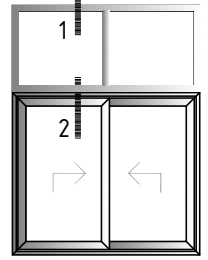
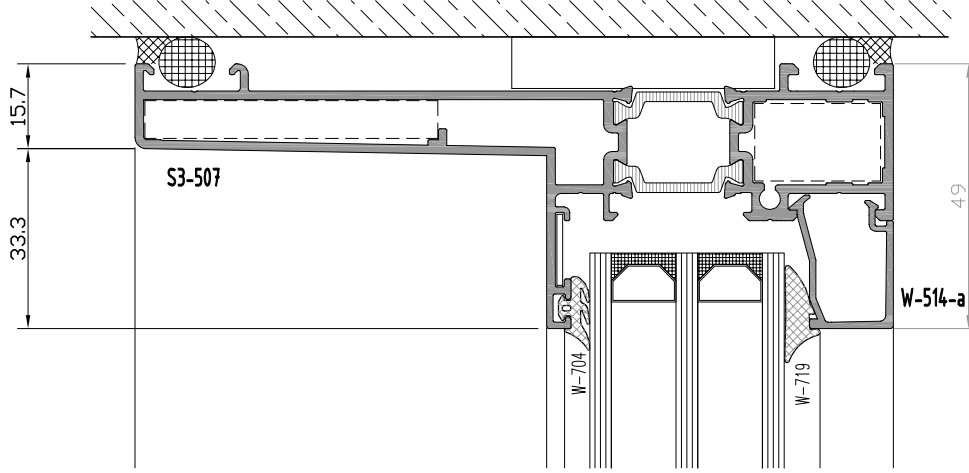

not to scale

S3

S 65-T YALITIMLI SÜRME SERİ

S65 -T INSULATED SLIDING SERIES

ÜST BİTİM - ORTA KAYIT DETAYI

TOP EDGE - MULLION DETAIL

1b

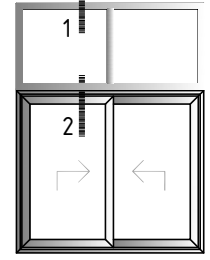
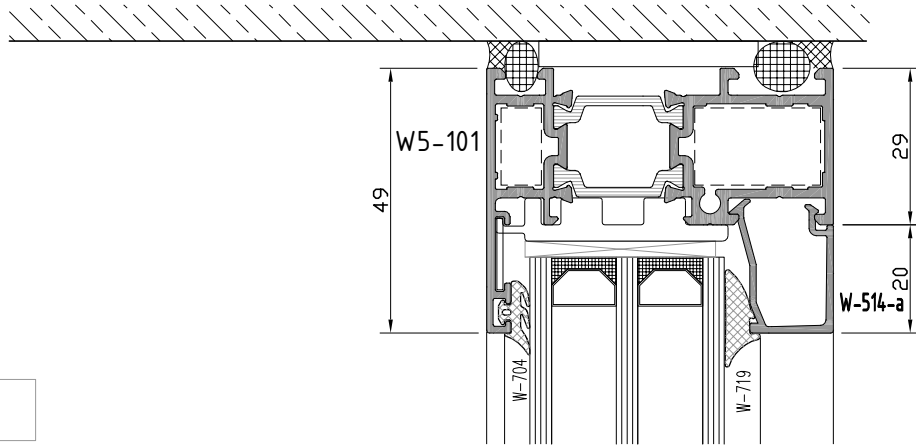

sistem birleşim detayları
System connection details

2b

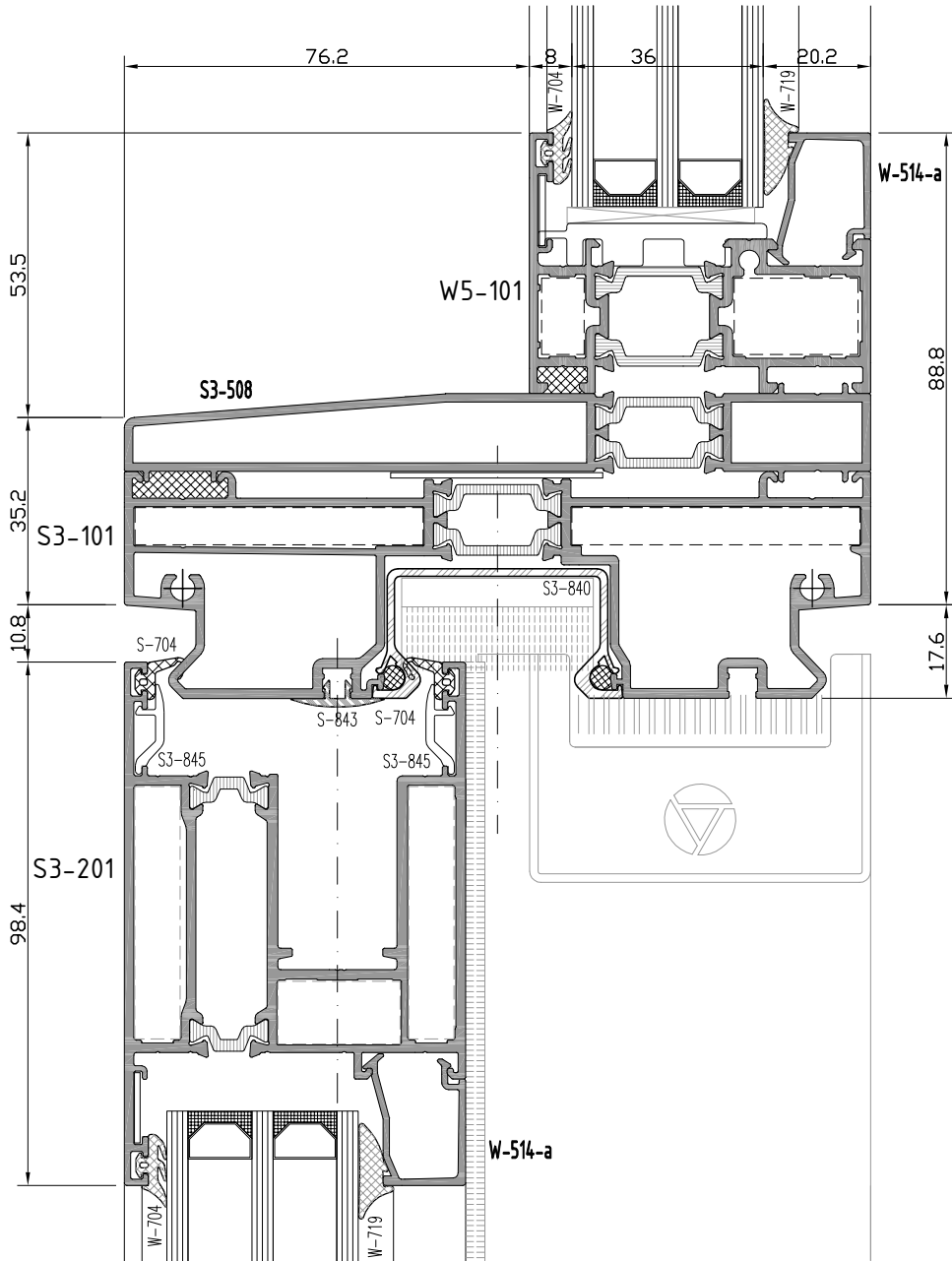

not to scale

S3

S 65-T YALITIMLI SÜRME SERİ

S65 -T INSULATED SLIDING SERIES

YAN BİTİM - ALT BİTİM DETAYI

WALL CONNECTION - BOTTOM EDGE DETAIL

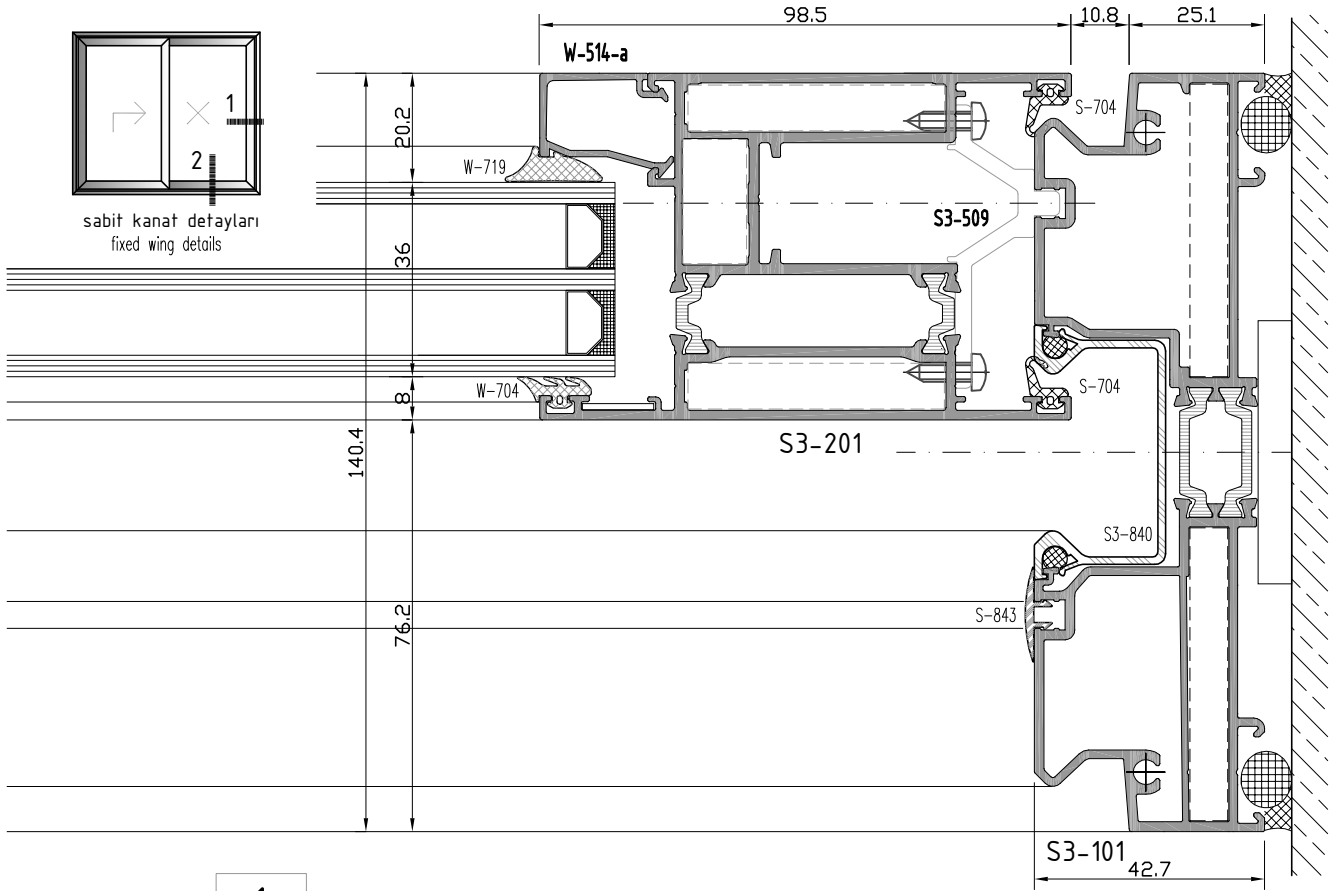

1

2

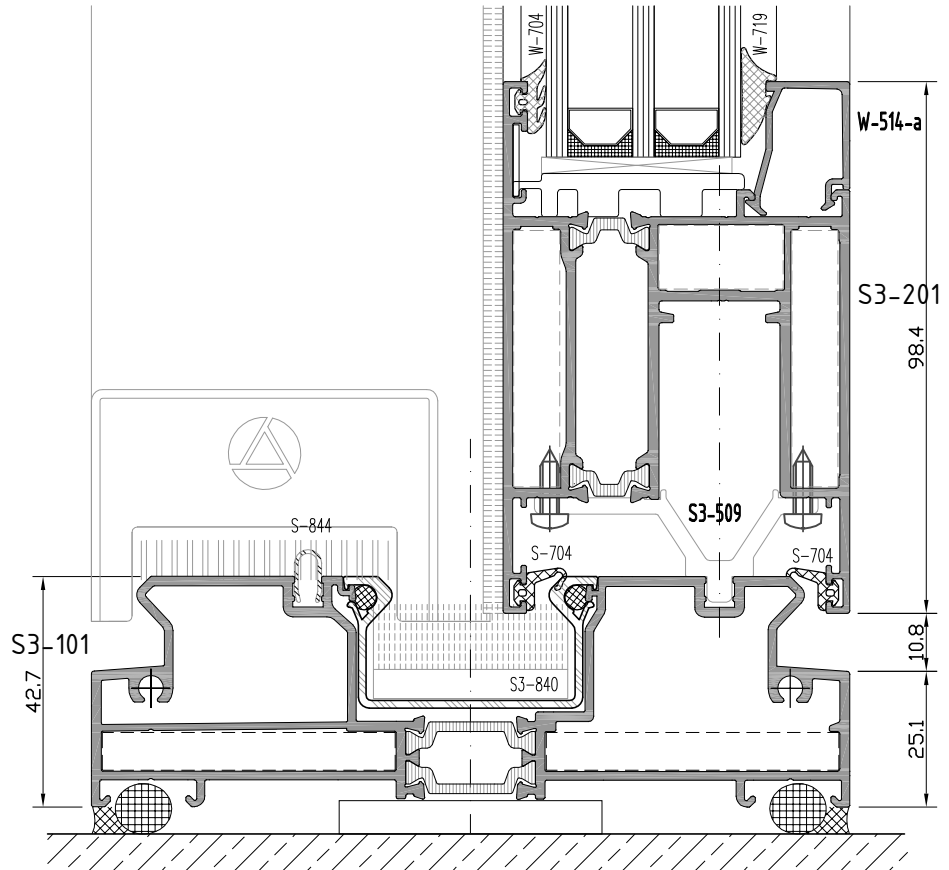

not to scale

S3

S 65-T YALITIMLI SÜRME SERİ

S65 -T INSULATED SLIDING SERIES

YAN BİTİM DETAYI

WALL CONNECTION DETAIL

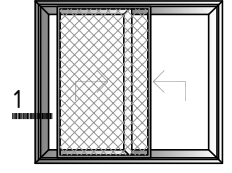

sineklik-damlık detayları
Flyscreen - weatherdrip details

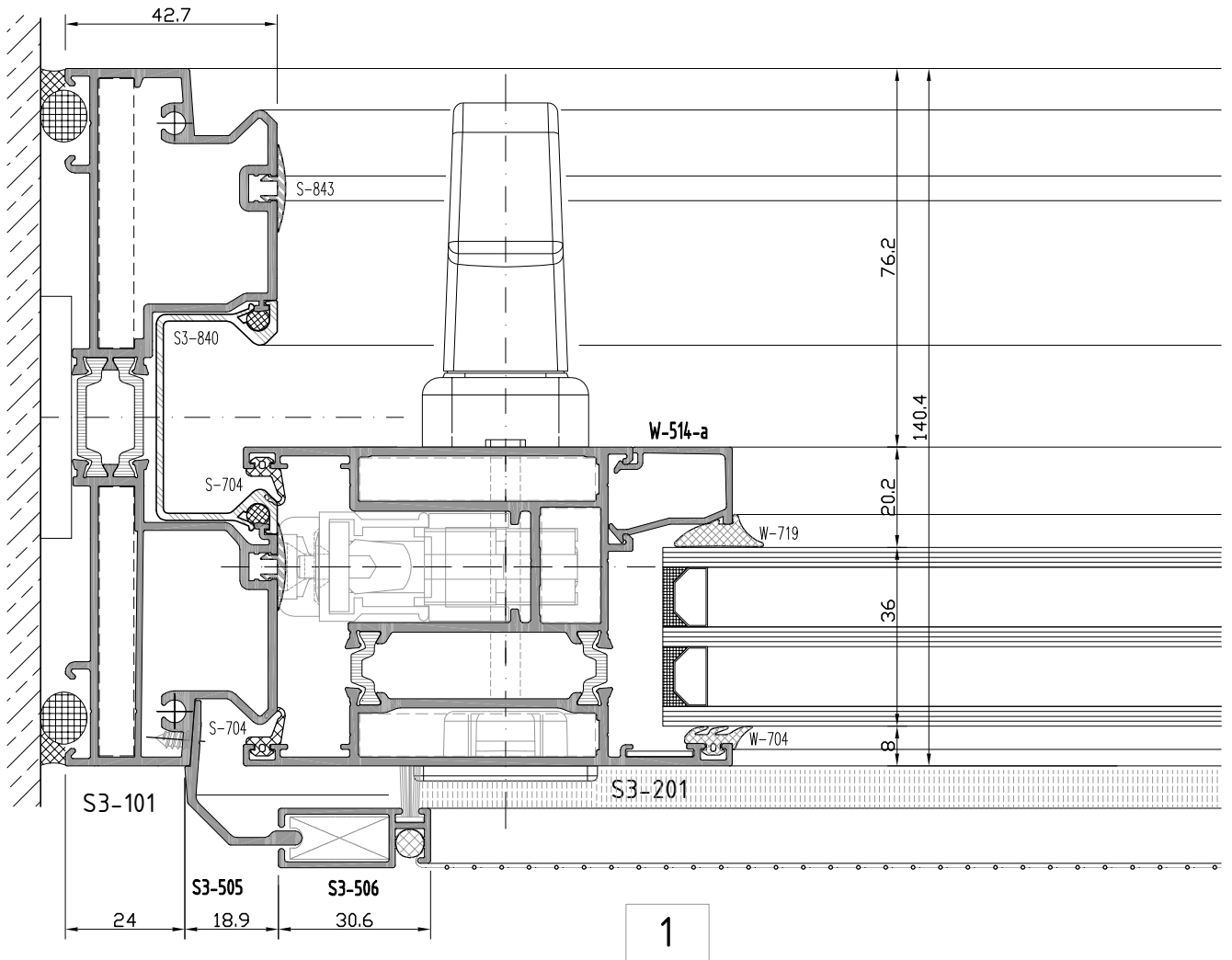

not to scale

S3

S 65-T YALITIMLI SÜRME SERİ

S65 -T INSULATED SLIDING SERIES

ORTA KAYIT DETAYI

MULLION DETAIL

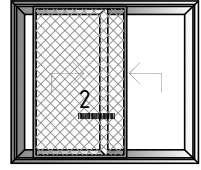

sineklik-damlık detayları
Flyscreen - weatherdrip details

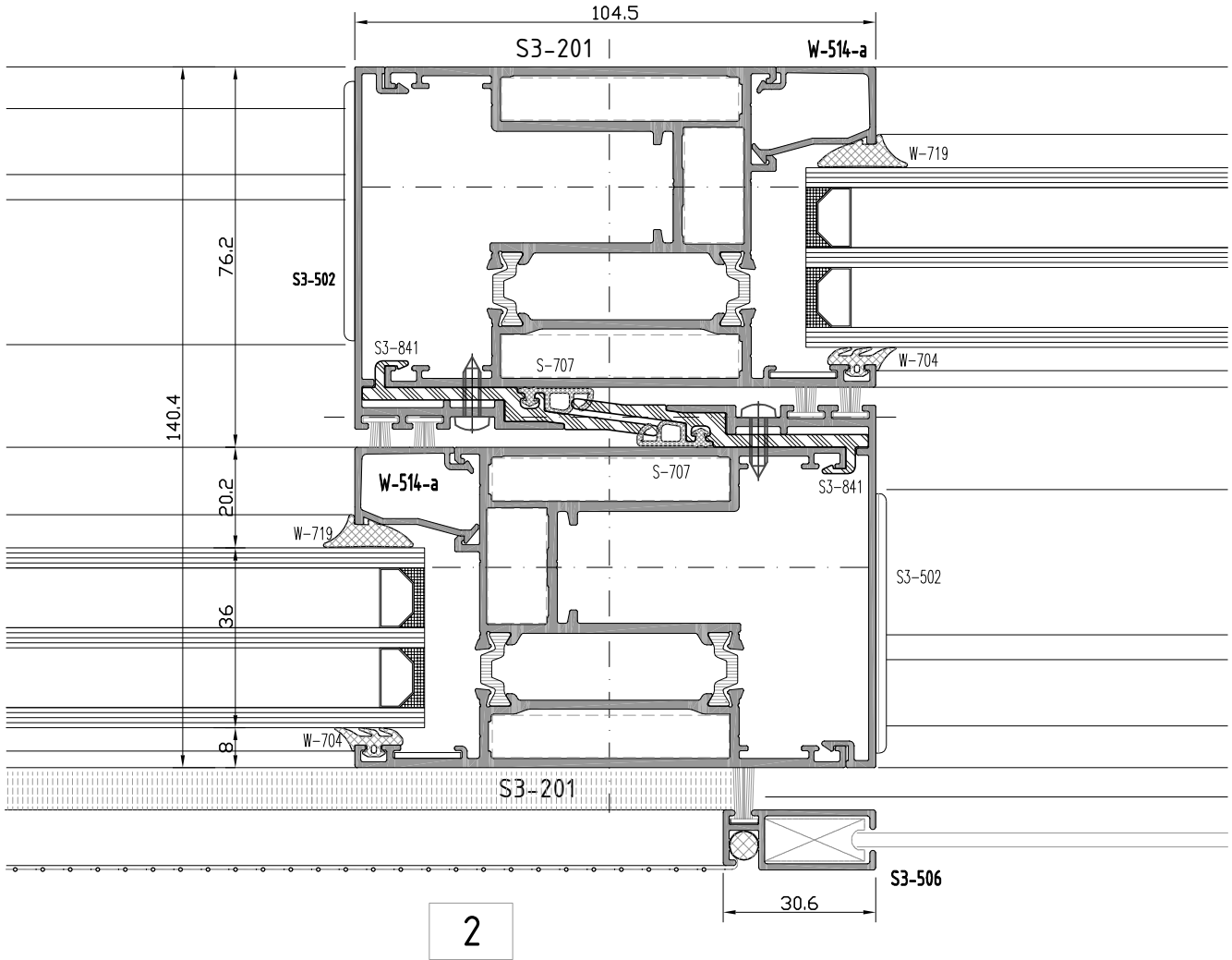

not to scale

S3
S 65-T YALITIMLI SÜRME SERİ
S65 -T INSULATED SLIDING SERIES

ÜST BİTİM - ALT BİTİM DETAYI
TOP EDGE - BOTTOM EDGE DETAIL

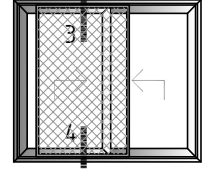
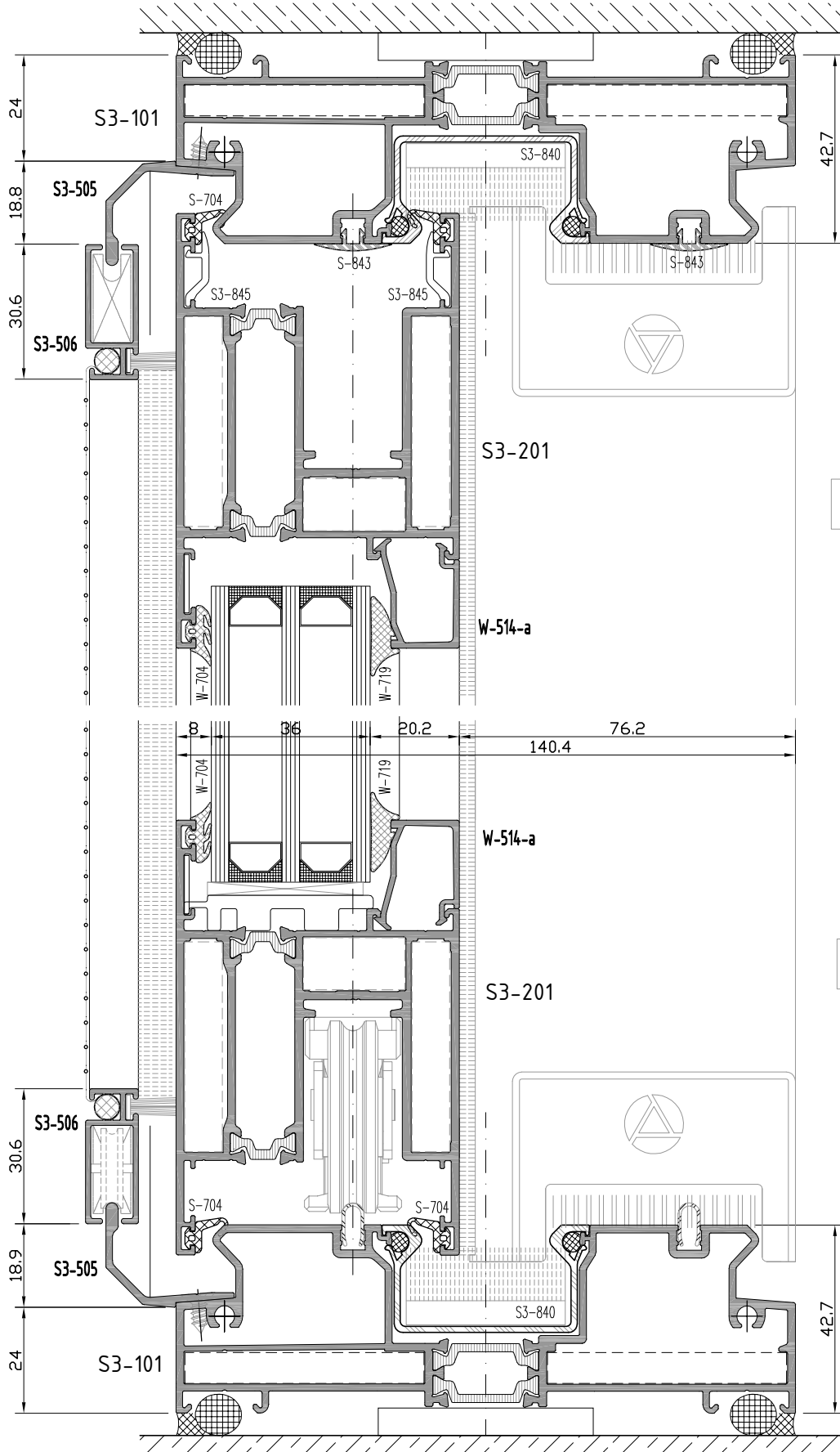

sineklik-damlık detayları
Flyscreen - weatherdrip details

3

4

not to scale

S3

S 65-T YALITIMLI SÜRME SERİ

S65 -T INSULATED SLIDING SERIES

YAN BİTİM DETAYI

WALL CONNECTION DETAIL

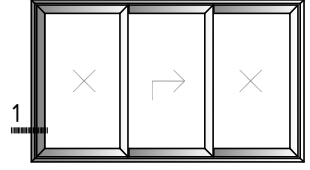

2 raylı sistem detayları
Double rail system details

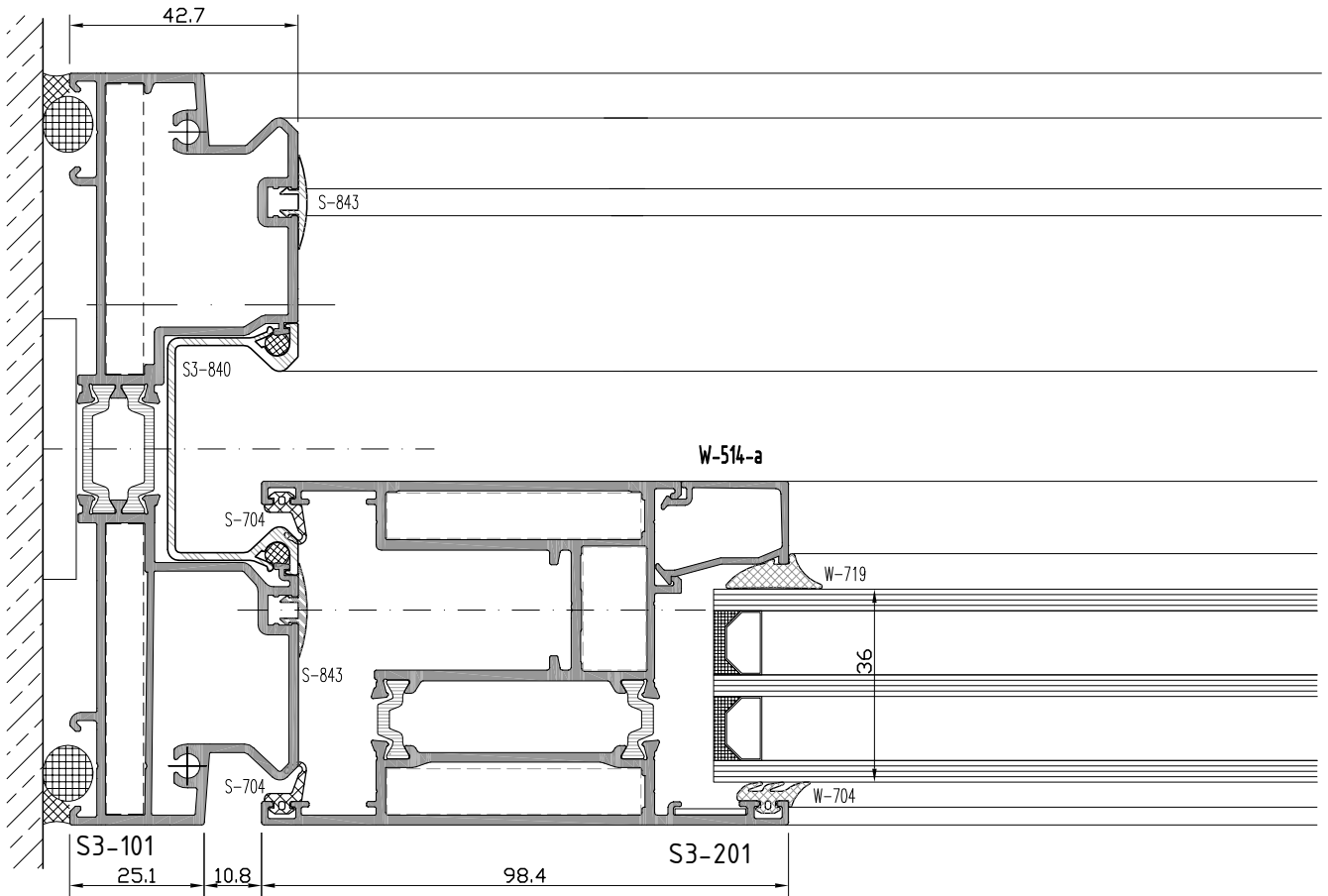

S3

S 65-T YALITIMLI SÜRME SERİ

S65 -T INSULATED SLIDING SERIES

ORTA KAYIT DETAYI

MULLION DETAIL

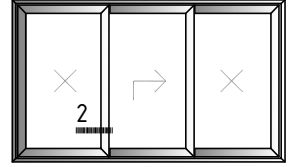

2 raylı sistem detayları
Double rail system details

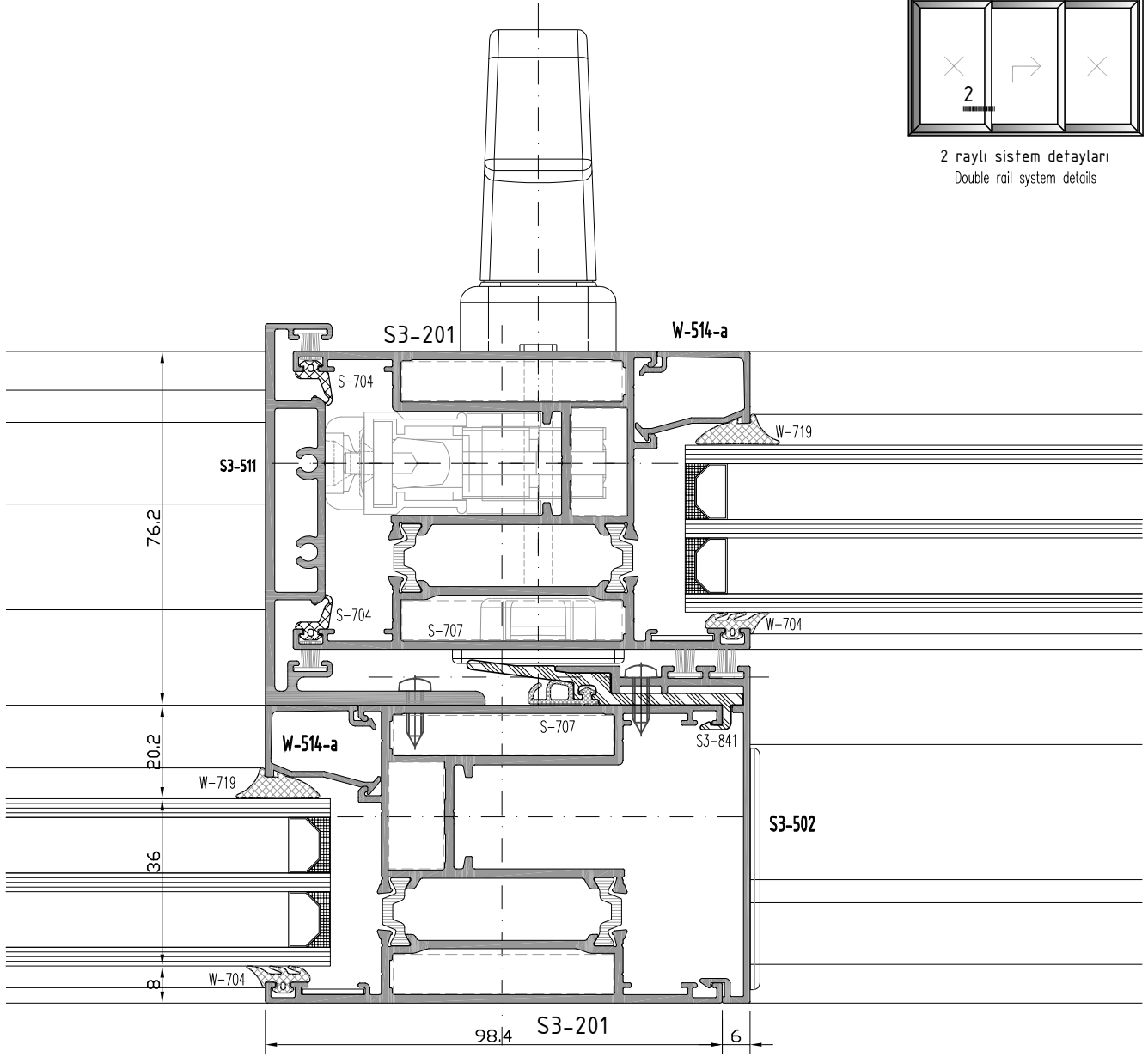

not to scale

S3

S 65-T YALITIMLI SÜRME SERİ

S65 -T INSULATED SLIDING SERIES

ORTA KAYIT DETAYI

MULLION DETAIL

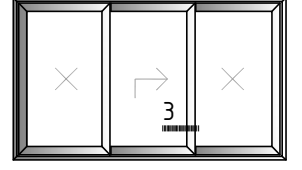

2 raylı sistem detayları
Double rail system details

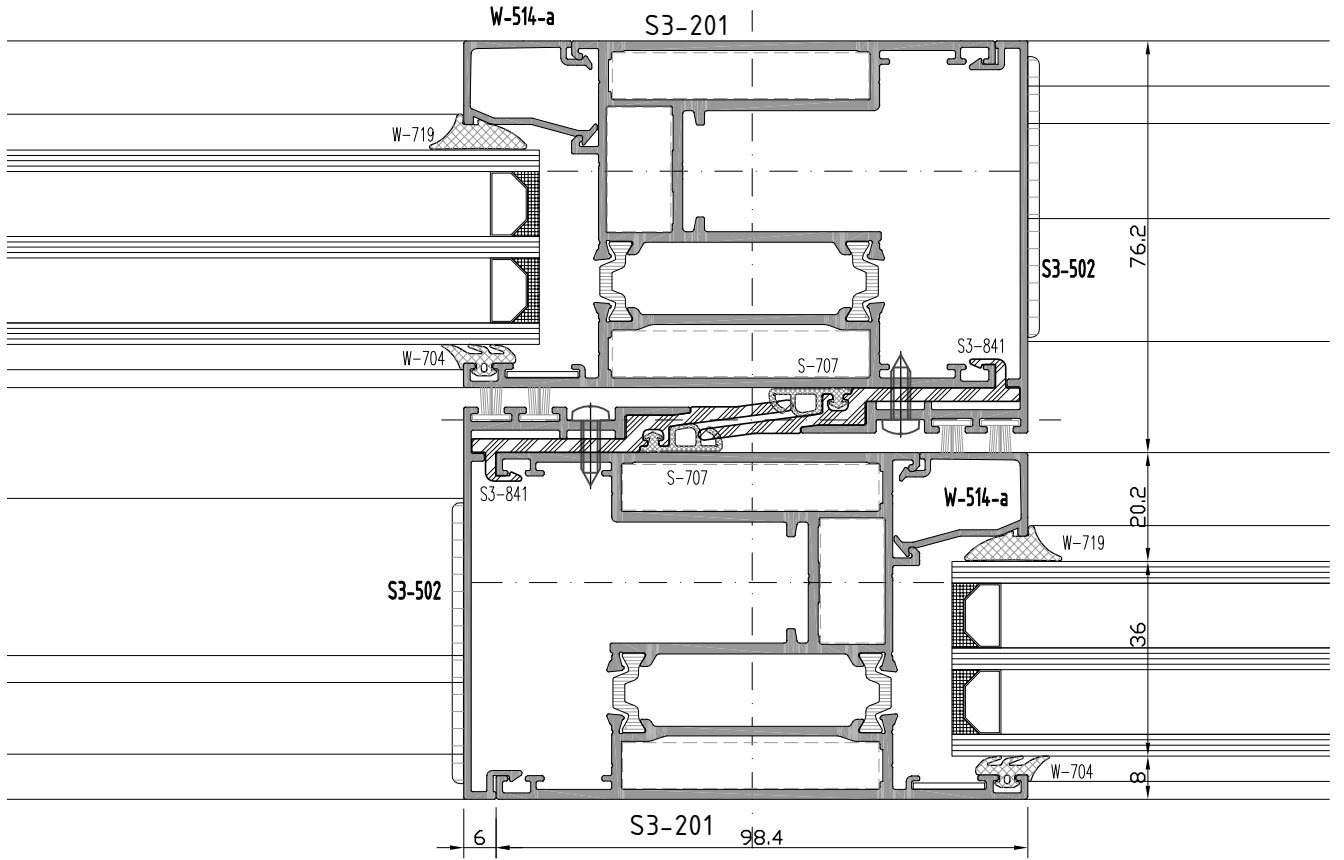

S3

S 65-T YALITIMLI SÜRME SERİ

S65 -T INSULATED SLIDING SERIES

YAN BİTİM DETAYI

WALL CONNECTION DETAIL

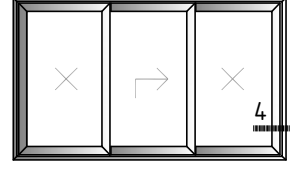

2 raylı sistem detayları
Double rail system details

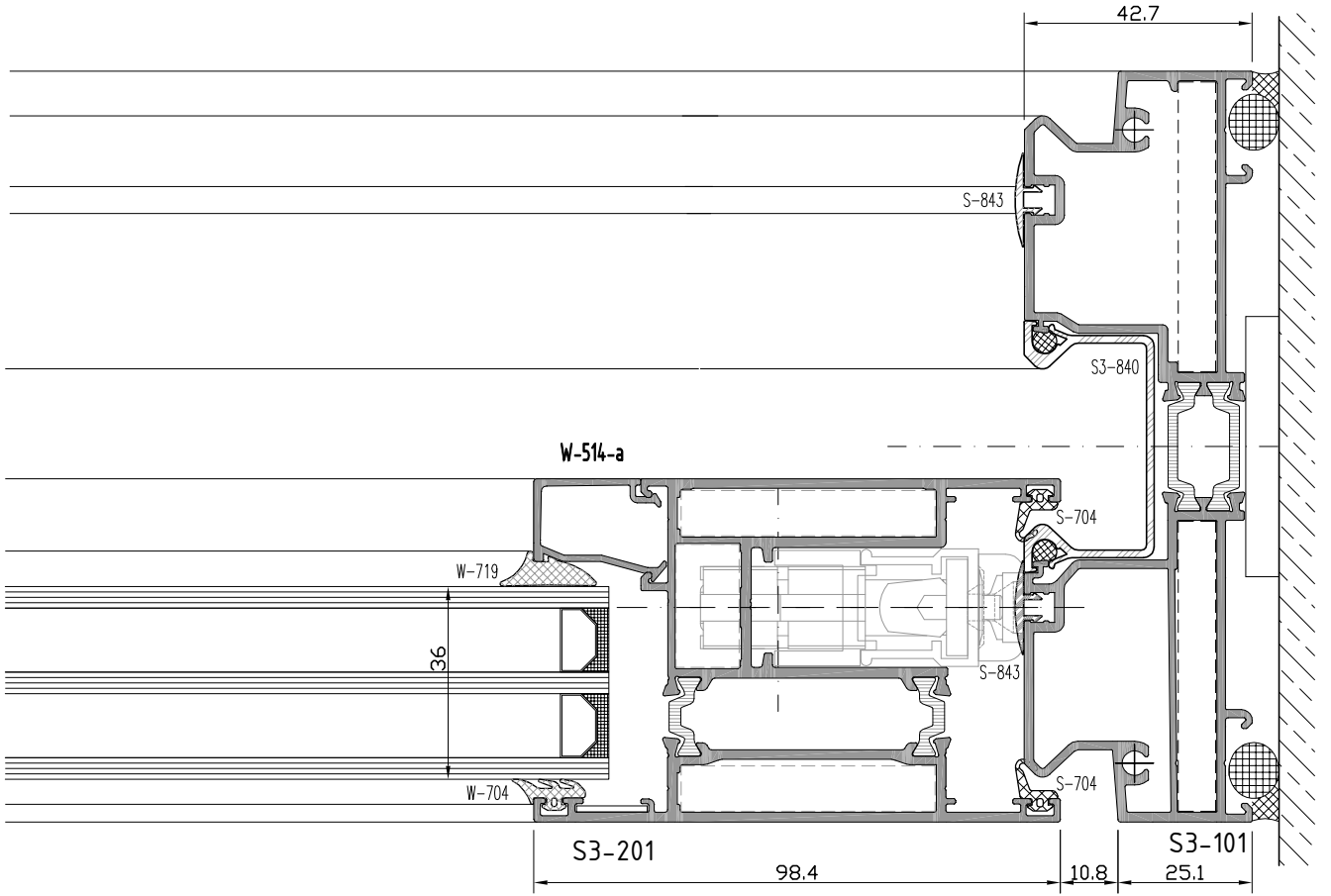

S3

S 65-T YALITIMLI SÜRME SERİ

S65 -T INSULATED SLIDING SERIES

YAN BİTİM DETAYI

WALL CONNECTION DETAIL

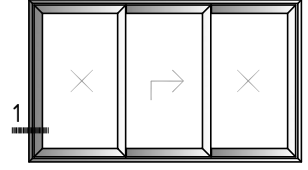

3 raylı sistem detayları
Triple rail system details

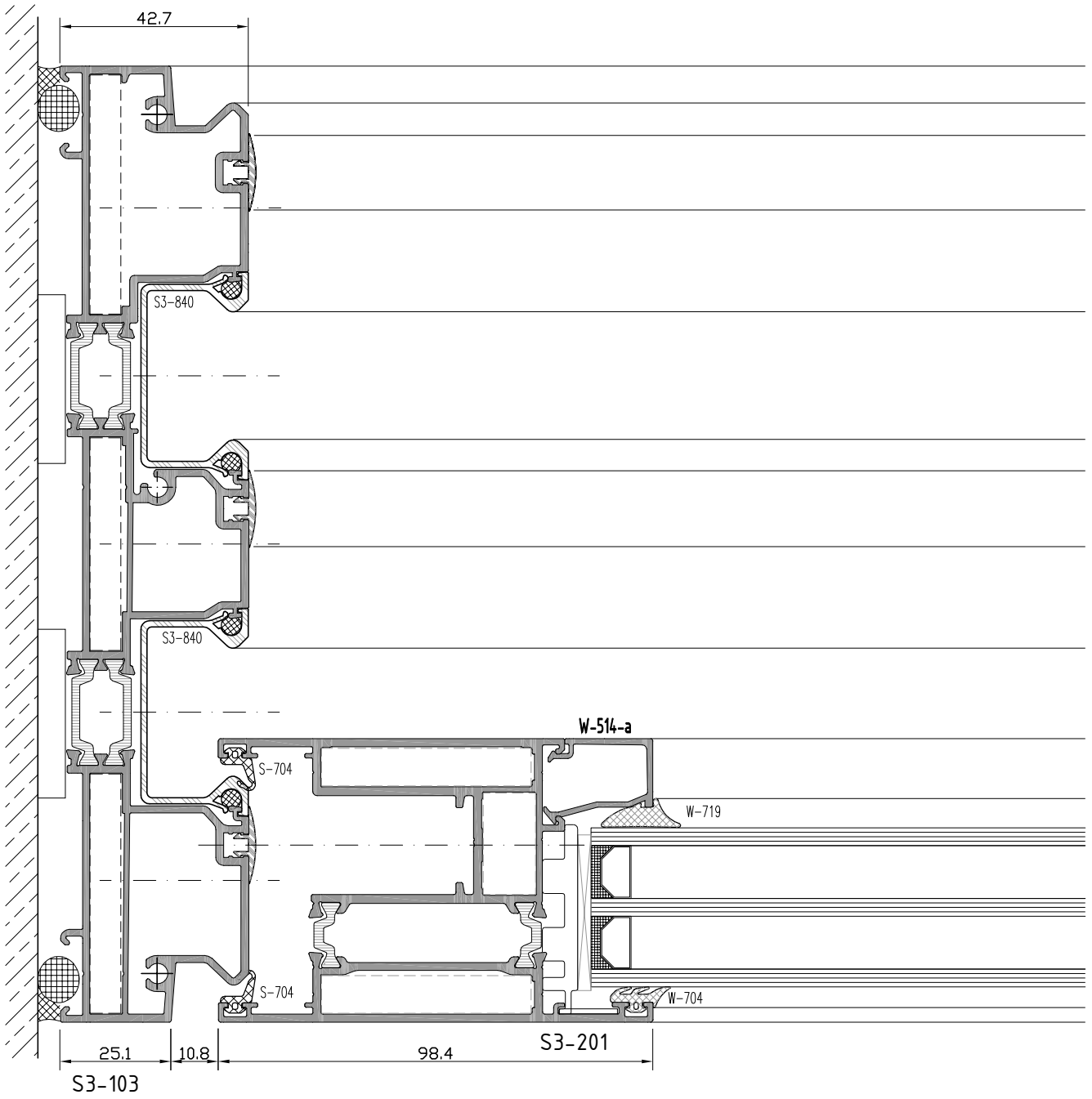

S3

S 65-T YALITIMLI SÜRME SERİ

S65 -T INSULATED SLIDING SERIES

ORTA KAYIT DETAYI

MULLION DETAIL

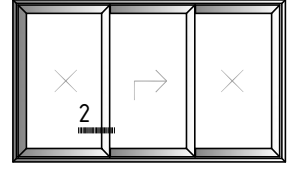

3 raylı sistem detayları
Triple rail system details

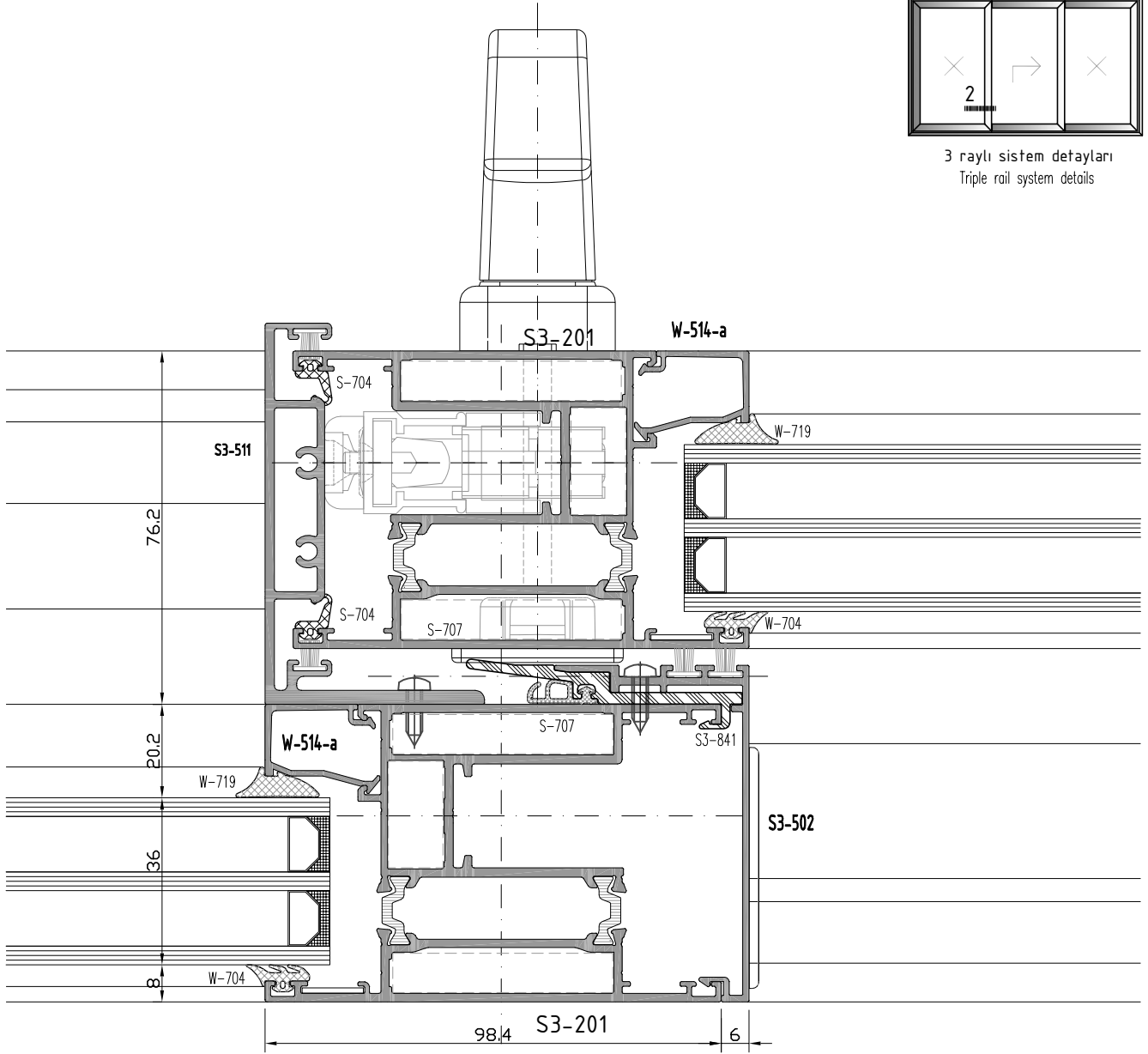

not to scale

S3

S 65-T YALITIMLI SÜRME SERİ

S65 -T INSULATED SLIDING SERIES

ORTA KAYIT DETAYI

MULLION DETAIL

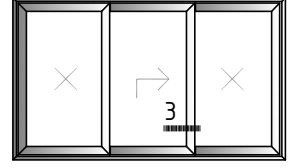

3 raylı sistem detayları
Triple rail system details

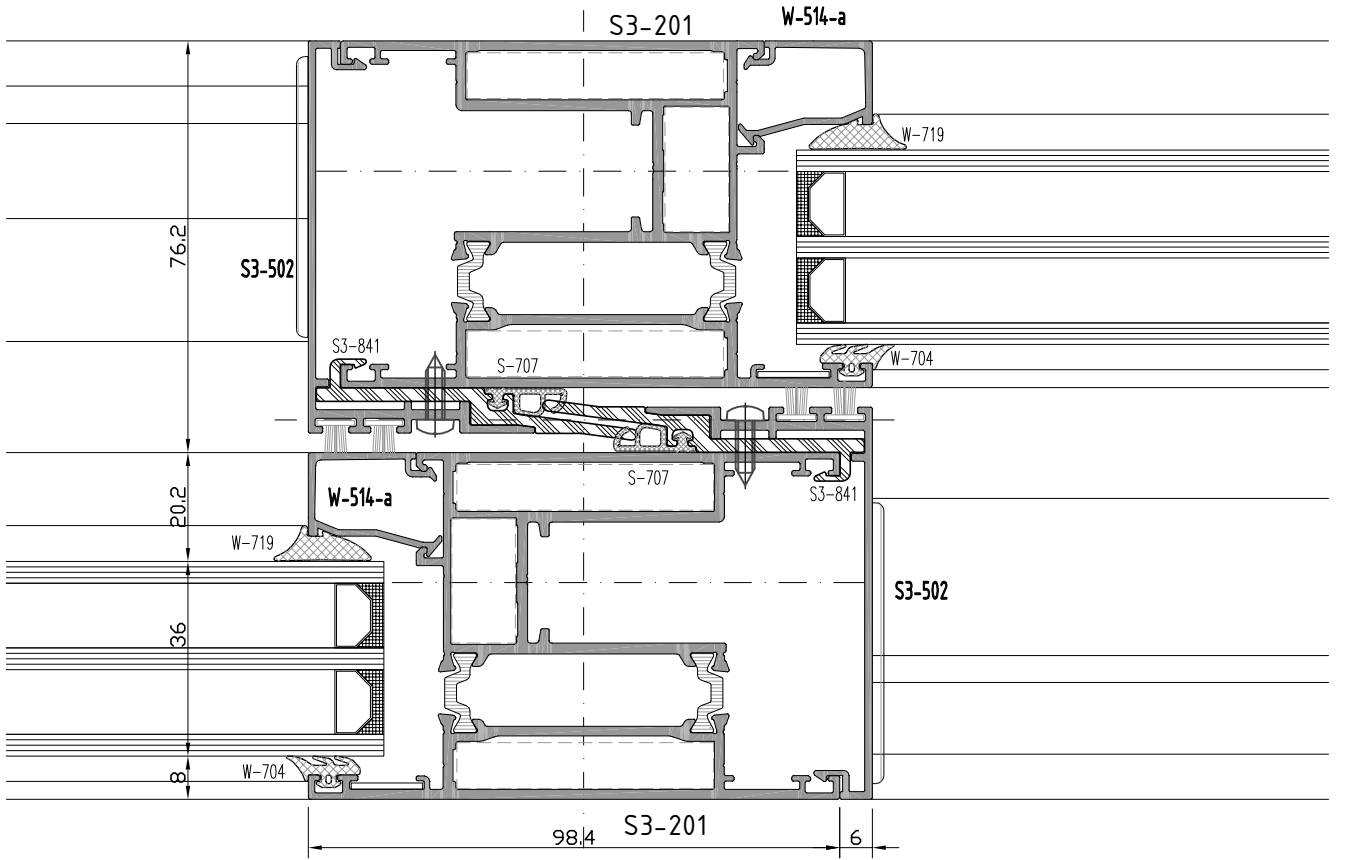

not to scale

S3

S 65-T YALITIMLI SÜRME SERİ

S65 -T INSULATED SLIDING SERIES

YAN BİTİM DETAYI

WALL CONNECTION DETAIL

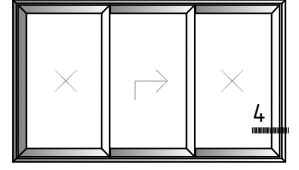

3 raylı sistem detayları
Triple rail system details

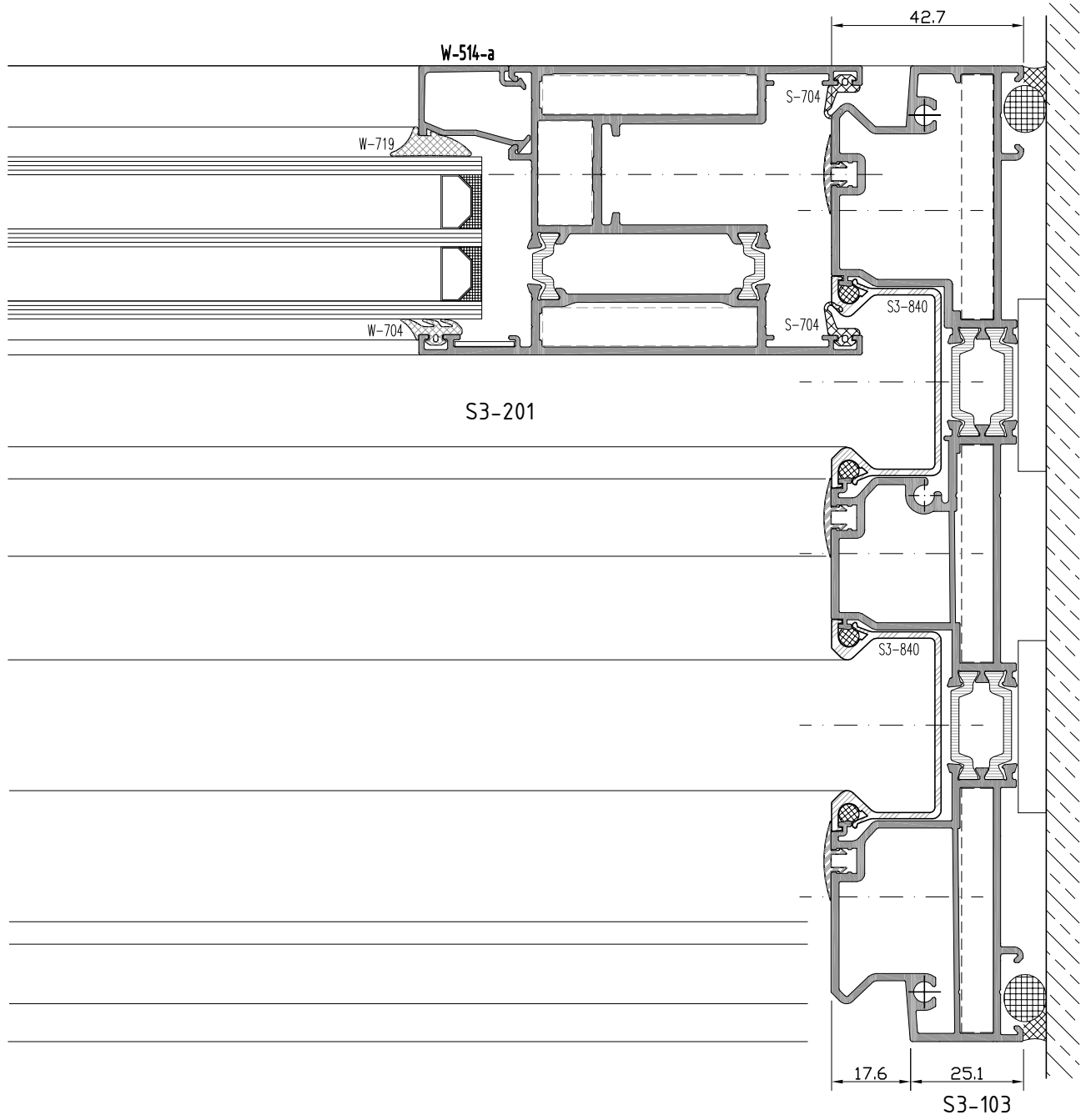

S3

S65-T YALITIMLI SÜRME SERİ

S65 -T INSULATED SLIDING SERIES

İMALAT ŞEMASI
PRODUCTION PLAN

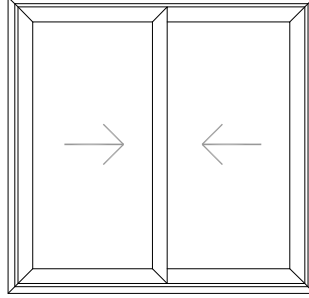
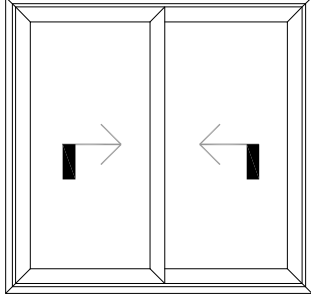

KALDIR SÜR SİSTEM
LIFT & SLIDE SYSTEM

$$KX = \frac{L+20}{2}$$

$$KY = H-72$$

$$G = B+28$$

Not : Cam ölçüleri eşit kabul edilerek formülize edilmiştir.

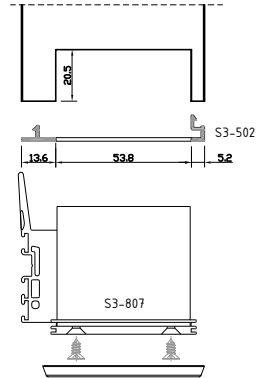
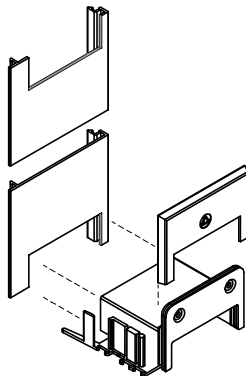
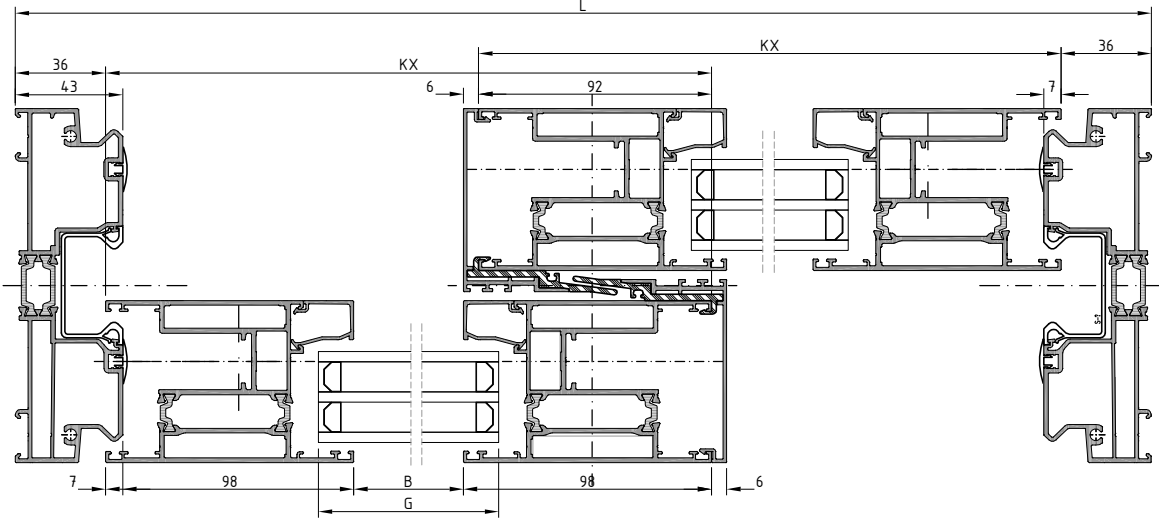
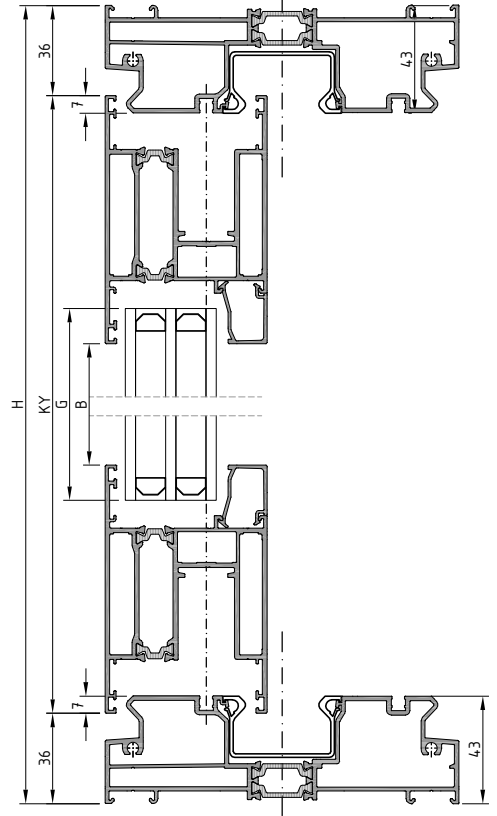

S3

S65-T YALITIMLI SÜRME SERİ S65 -T INSULATED SLIDING SERIES

İMALAT ŞEMASI
PRODUCTION PLAN

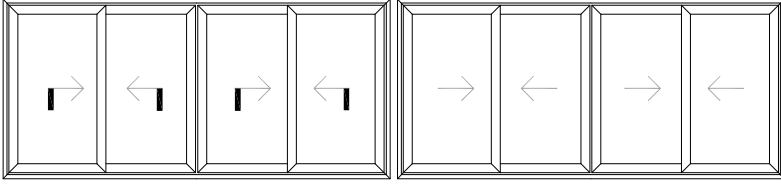

KALDIR SÜR SİSTEM
LIFT & SLIDE SYSTEM

$$KX = \frac{L+105}{4}$$

$$KY = H-72$$

$$G = B+28$$

Not : Cam ölçüleri eşit kabul edilerek formülize edilmiştir.

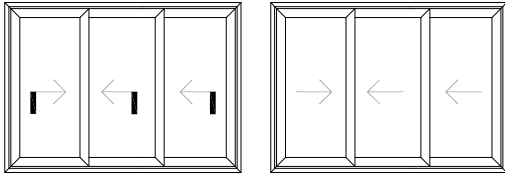
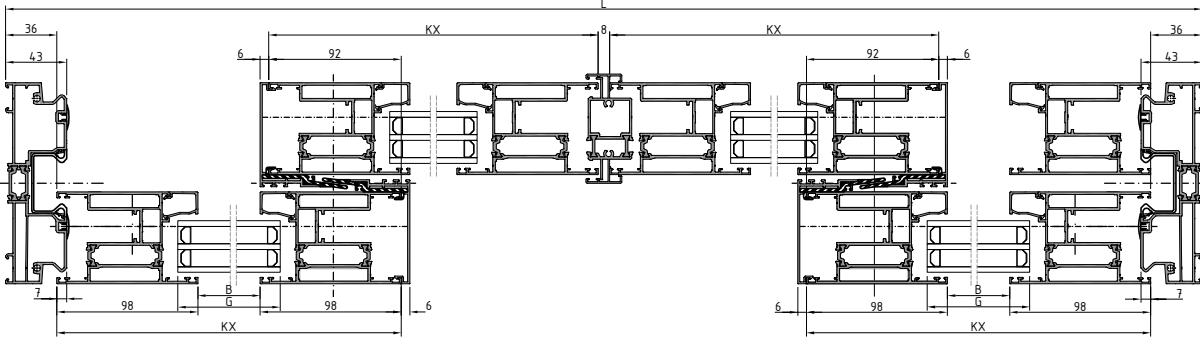
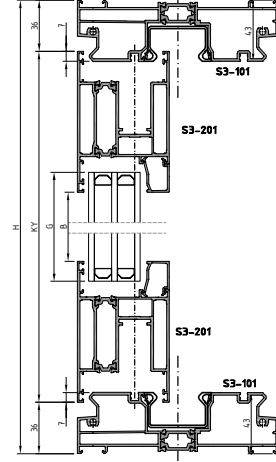

$$KX = \frac{L+113}{3}$$

$$KY = H-72$$

$$G = B+28$$

Not : Cam ölçüleri eşit kabul edilerek formülize edilmiştir.

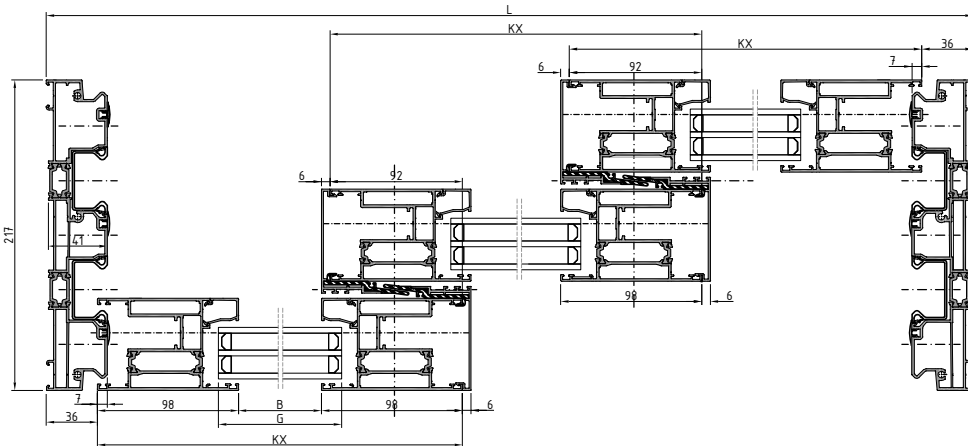
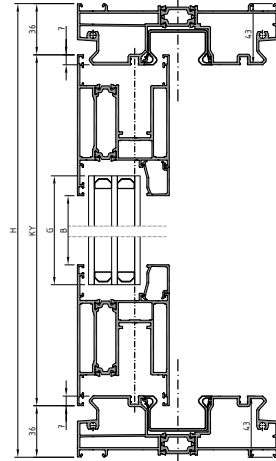

S3

S65-T YALITIMLI SÜRME SERİ S65 -T INSULATED SLIDING SERIES

İMALAT ŞEMASI
PRODUCTION PLAN

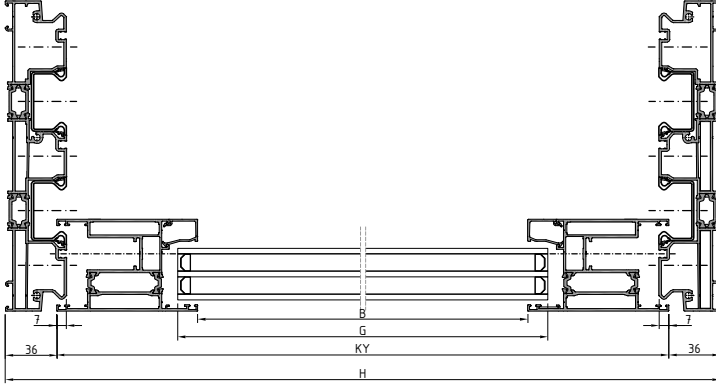

$KX = \frac{L+290}{6}$
$KY = H-72$
$G = B+28$

Not : Cam ölçüleri eşit kabul edilerek formülize edilmiştir.

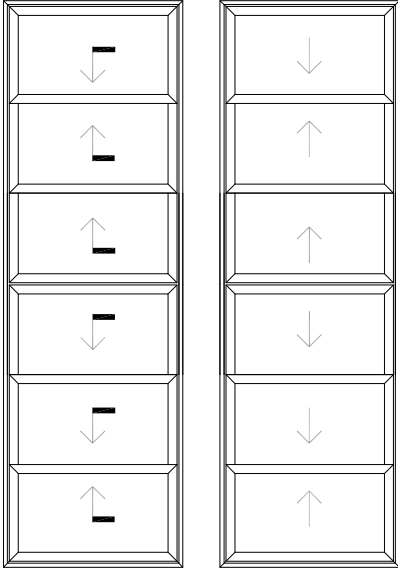

KALDIR SÜR SİSTEM
LIFT & SLIDE SYSTEM

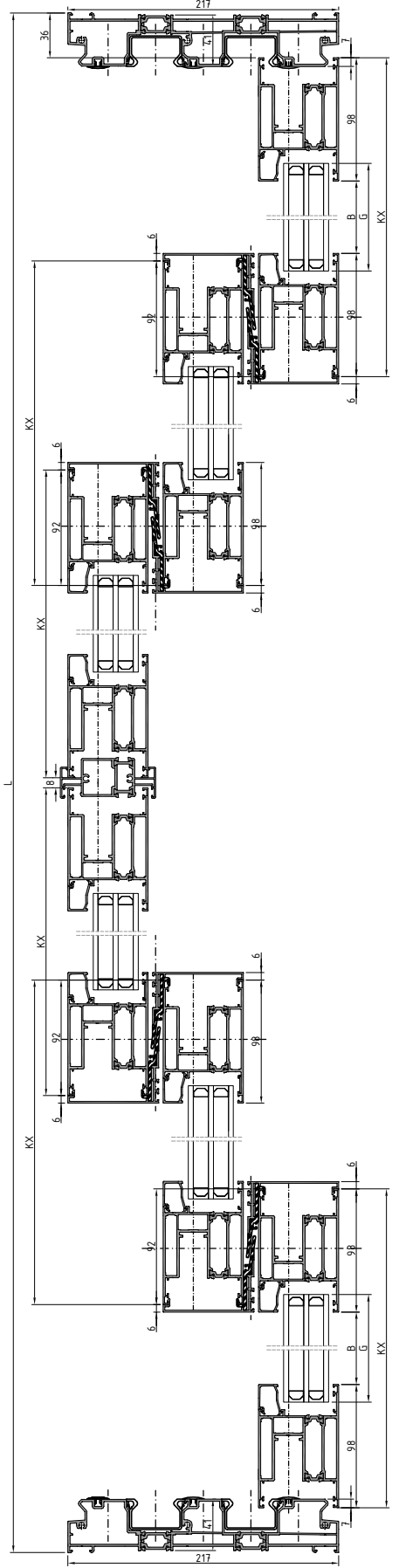

S3

S65-T YALITIMLI SÜRME SERİ

S65 -T INSULATED SLIDING SERIES

İMALAT ŞEMASI
PRODUCTION PLAN

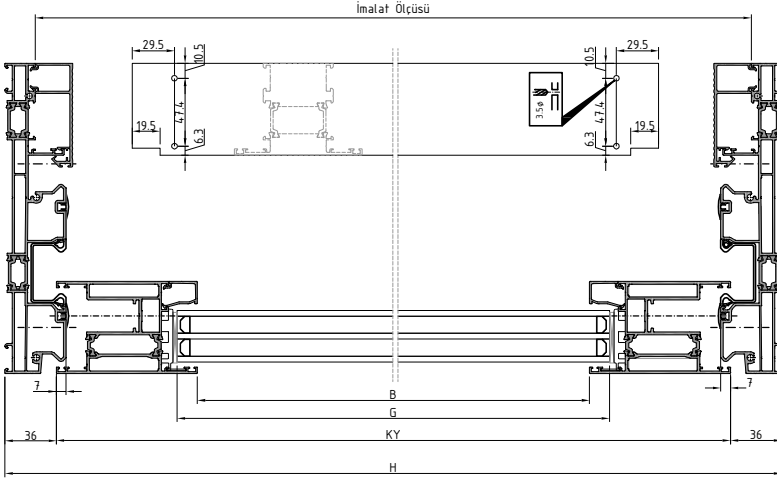

$KX = \frac{L+474}{6}$
$KY = H-72$
$G = B+28$

Not : Cam ölçüleri eşit kabul edilerek formülize edilmiştir.

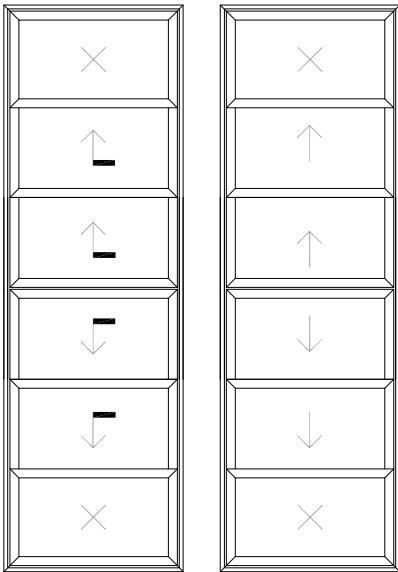

KALDIR SÜR SİSTEM
LIFT & SLIDE SYSTEM

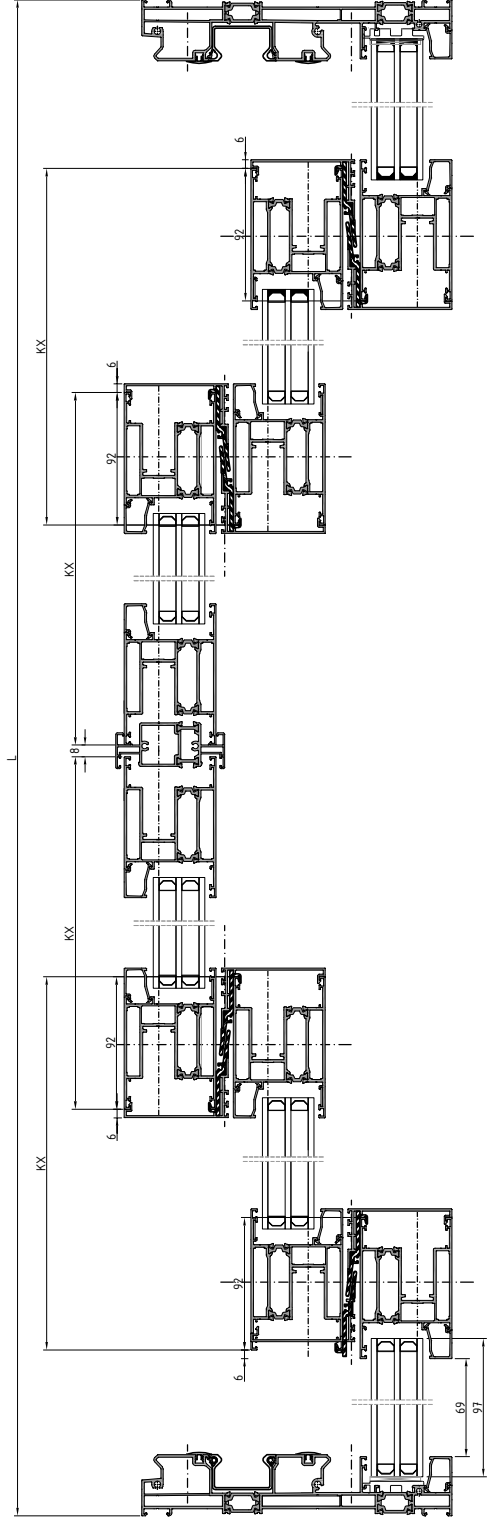

S3

S65-T YALITIMLI SÜRME SERİ S65 -T INSULATED SLIDING SERIES

İMALAT ŞEMASI
PRODUCTION PLAN

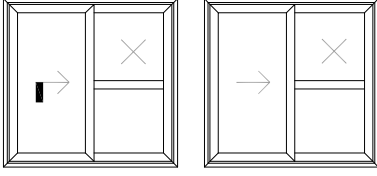

$KX = \frac{L+123}{2}$
$KY = H-72$
$G = B+28$

Not : Cam ölçüleri eşit kabul edilerek formülize edilmiştir.

KALDIR SÜR SİSTEM
LIFT & SLIDE SYSTEM

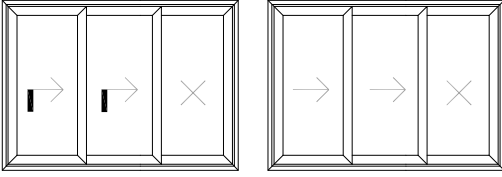
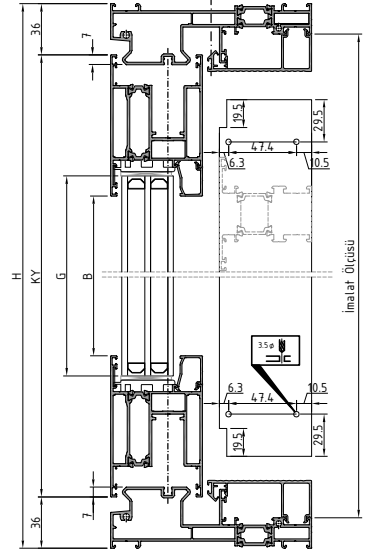
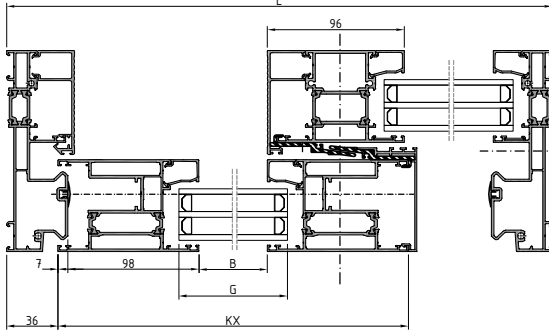

KALDIR SÜR SİSTEM
LIFT & SLIDE SYSTEM

$KX = \frac{L+215}{3}$
$KY = H-72$
$G = B+28$

Not : Cam ölçüleri eşit kabul edilerek formülize edilmiştir.

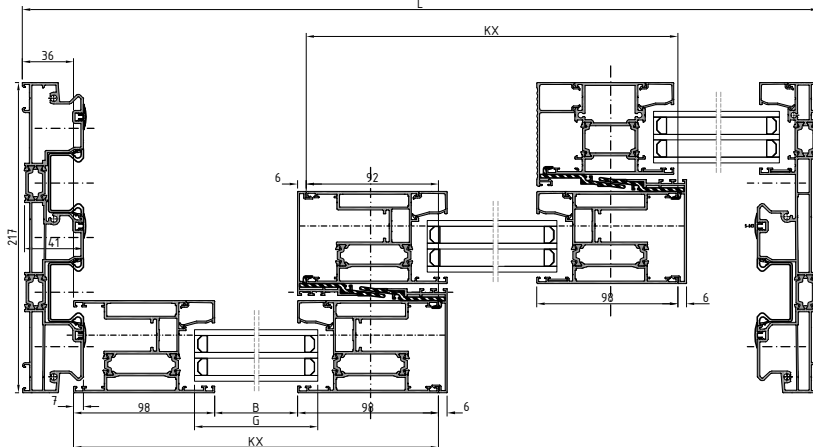
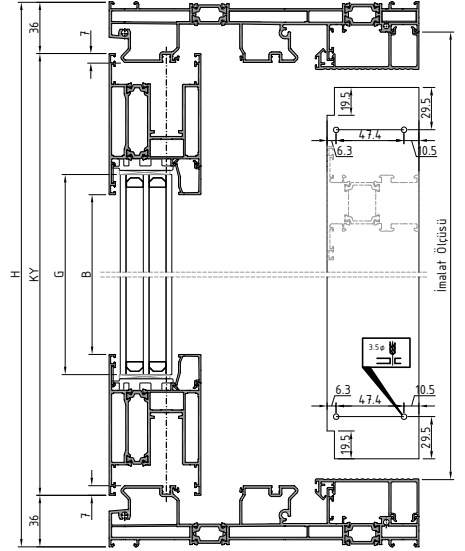



S65 SERİ PROFİLLERİ

S65 PROFILES SERIE

Fıtıl listesi

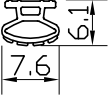
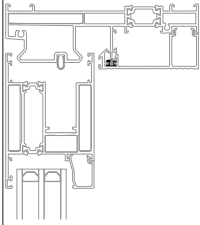
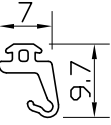
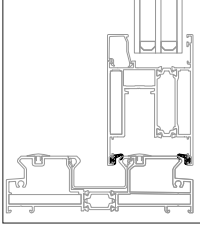
Gasket list

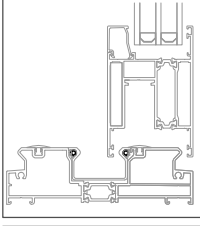
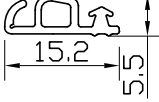
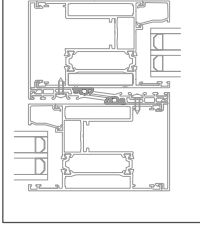
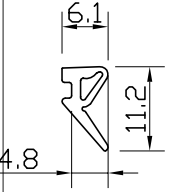
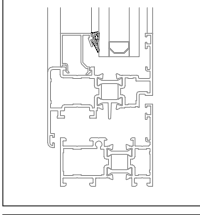
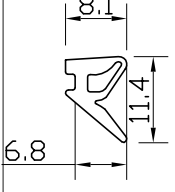
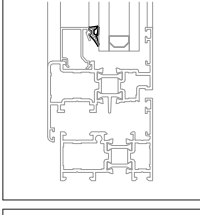
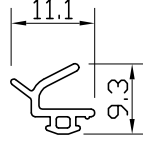
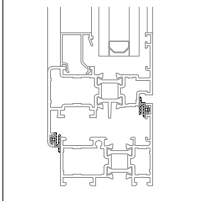
kod code	şekil drawing	tanım description	teorik ağırlık theoretical weight gr / m	paket ağırlığı package weight kg / package	paket metrajı in one package metre / package	kullanım yeri aplication
S-701		tpv fıtıl tpv gasket	23 gr/m	15 kg	650 m	
S-704		epdm fıtıl epdm gasket	35 gr/m	15 kg	428 m	
S-705		epdm fıtıl epdm gasket	16 gr/m	15 kg	938 m	
S-707		epdm fıtıl epdm gasket	43 gr/m	15 kg	349 m	
W-701		epdm cam iç fıtıl glazing gasket inside	41gr/m	15 kg	366 m	
W-702		epdm cam iç fıtıl glazing gasket inside	49 gr/m	15 kg	306 m	
W-703		epdm çarpma iç-dış fıtıl glazing acoustical (epdm)	33 gr/m	15 kg	440 m	

S65 SERİ PROFİLLERİ

S65 PROFILES SERIE

Fitil listesi

Gasket list

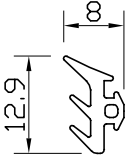
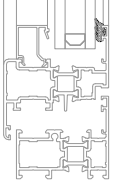
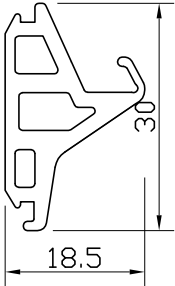
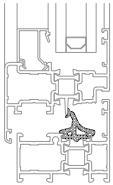
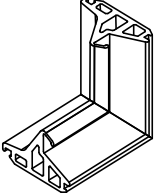
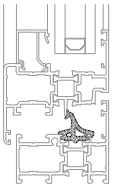
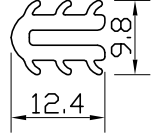
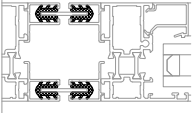
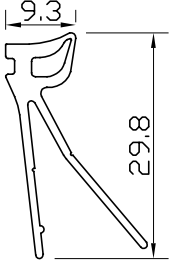
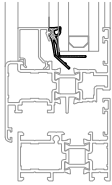
kod code	şekil drawing	tanım description	teorik ağırlık theoretical weight gr / m	paket ağırlığı package weight kg / package	paket metraji in one package metre / package	kullanım yeri aplication
W-704		epdm cam dış fitil glazing gasket outside (epdm)	50 gr/m	15 kg	300 m	
W65-705		epdm tozluk fitil central gasket (epdm)	221,5 gr/m	150 kg	68 m	
W65-706		köşe tozluk fitil central gasket (epdm)	25,5 gr/m	-	50 ad-pcs	
W-709		profil ara fitil gasket between profile (epdm)	82gr/m	15kg	183 m	
W-715		epdm cam iç fitil glazing gasket inside	119 gr/m	15 kg	126 m	

S65 SERİ PROFİLLERİ

S65 PROFILES SERIE

Fitil listesi

Gasket list

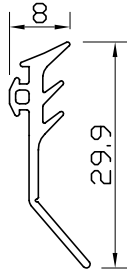
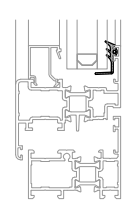
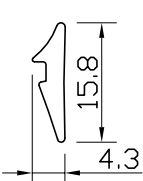
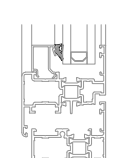
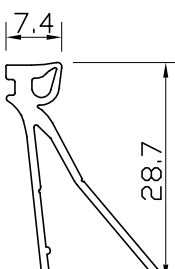
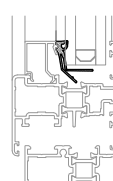
kod code	şekil drawing	tanım description	teorik ağırlık theoretical weight gr / m	paket ağırlığı package weight kg / package	paket metraji in one package metre / package	kullanım yeri aplication
W-716		epdm cam dış fitil glazing gasket outside (epdm)	77 gr/m	15 kg	195 m	
W-718		epdm cam iç fitil glazing gasket inside	52 gr/m	15 kg	288 m	
W-720		epdm cam iç fitil glazing gasket inside	77 gr/m	15 kg	195 m	

S65 SERİ PROFİLLERİ

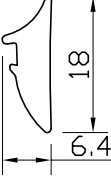
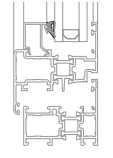
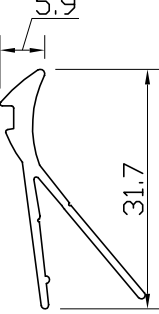
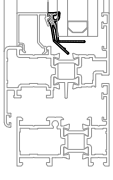
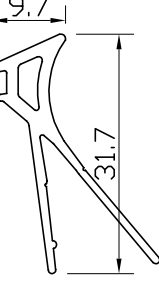
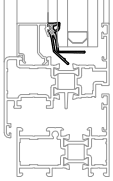

S65 PROFILES SERIE

Fitil listesi
Gasket list

kod code	şekil drawing	tanım description	teorik ağırlık theoretical weight gr / m	paket ağırlığı package weight kg / package	paket metrajı in one package metre / package	kullanım yeri aplication
W-719		epdm cam iç fitil glazing gasket inside	88 gr/m	15 kg	170 m	
W-721		epdm cam iç fitil glazing gasket inside	107 gr/m	15 kg	140 m	
W-722		epdm cam iç fitil glazing gasket inside	125 gr/m	15 kg	120 m	

S65-T YALITIMLI SÜRME SERİ
S65 –T INSULATED SLIDING SERIES

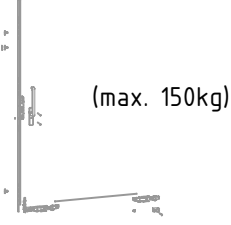
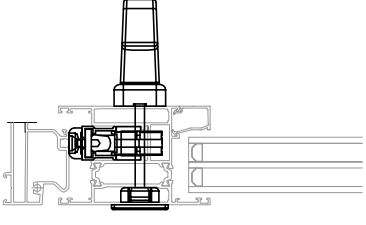
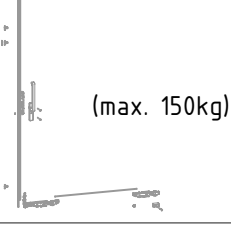
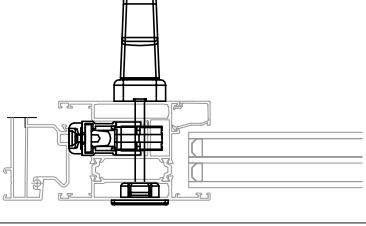
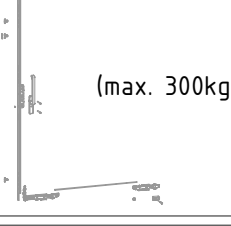
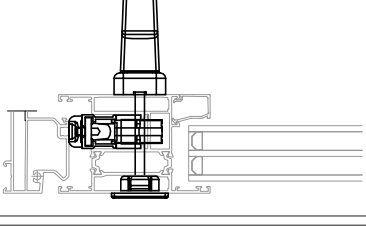
AÇILIM MEKANİZMALARI
OPENING MECHANISMS

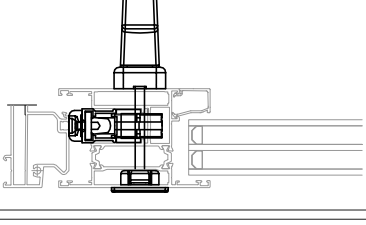
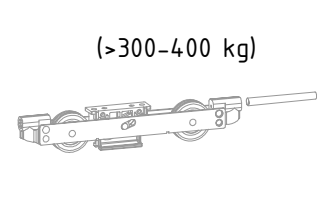
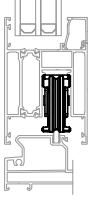
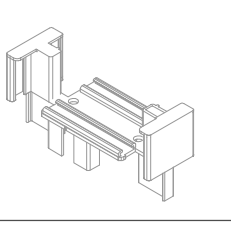
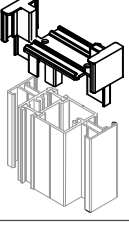
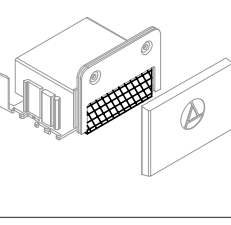
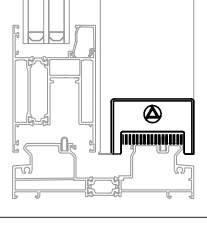
kod code	şekil drawing	tanım description	kullanım yeri aplication
S3-801	 <p>(max. 150kg)</p>	Kaldır-sür mekanizması naturel eloksalli Lift & sliding mecanism mat anodized	
S3-802	 <p>(max. 150kg)</p>	Kaldır-sür mekanizması pres veya renkli Lift & sliding mecanism mill finishand and painted	
S3-803	 <p>(max. 300kg)</p>	Kaldır-sür mekanizması naturel eloksalli Lift & sliding mecanism mat anodized	
S3-804	 <p>(max. 300kg)</p>	Kaldır-sür mekanizması pres veya renkli Lift & sliding mecanism mill finishand and painted	
S3-805	 <p>(>300-400 kg)</p>	Kaldır-sür ek rulman Kit pulleys lift&slide	
S3-806		Dörtlü kanat tapası Flug for 4 vent	
S3-807		Kenet kapağı Locking cover	

S65-T YALITIMLI SÜRME SERİ
S65 -T INSULATED SLIDING SERIES

AÇILIM MEKANİZMALARI
OPENING MECHANISMS

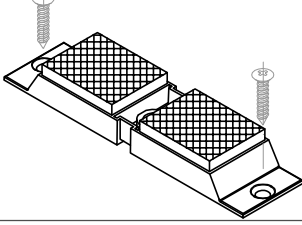
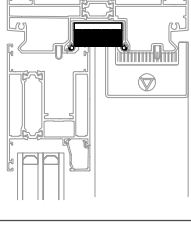
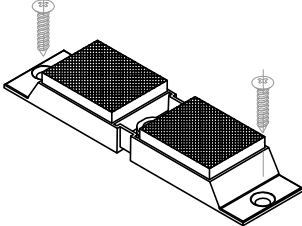
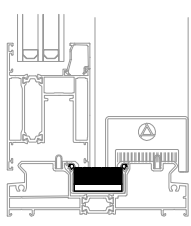
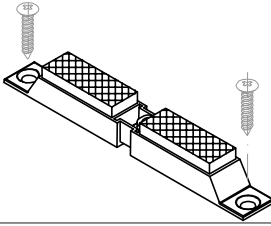
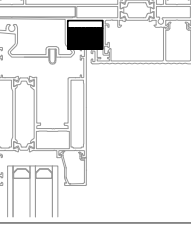
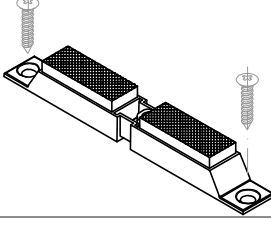
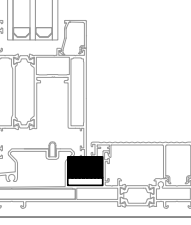
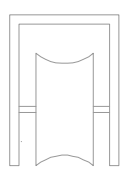
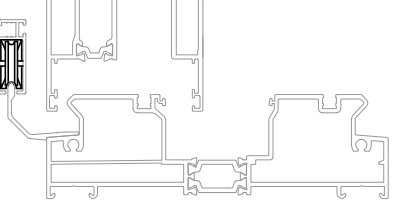
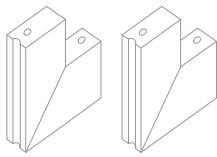
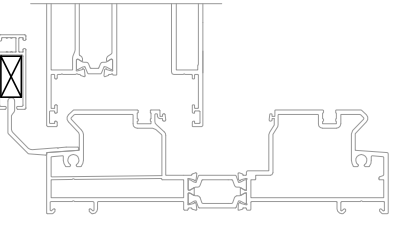
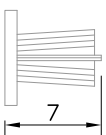
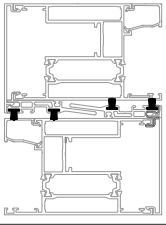
kod code	şekil drawing	tanım description	kullanım yeri application
S3-808		Üst hava kesici Upper air stopper	
S3-808-a		Alt hava kesici Lower air stopper	
S3-809		Üst hava kesici Upper air stopper	
S3-810		Alt hava kesici Lower air stopper	
S3-811		Sineklik rulmanı Screening roller	
S3-812		Sineklik köşe takozu Screening corner joint	
S-702		Kıl fitil 7mm brush 7mm	



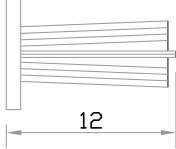
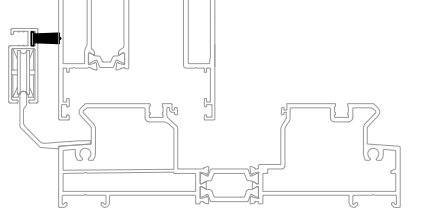
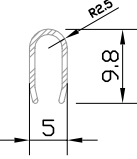
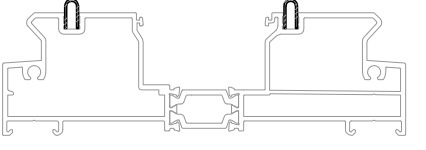
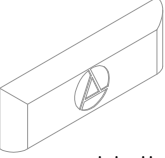
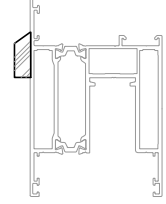
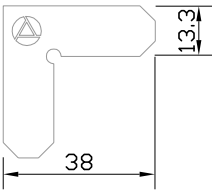
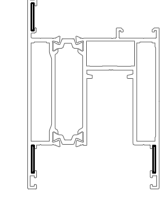
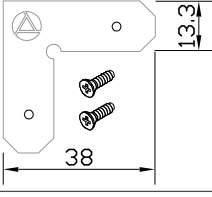
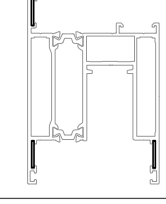

S65-T YALITIMLI SÜRME SERİ
S65 -T INSULATED SLIDING SERIES

AÇILIM MEKANİZMALARI
OPENING MECHANISMS

kod code	şekil drawing	tanım description	kullanım yeri aplication
S-703		Kıl fitil 12mm brush 12mm	
S-844		Çelik ray Stainless steel	
D-870	 (renk seçeneği belirtilmelidir) (colour choice must be stated)	Su tahliye parçası Drainage hole cover	
D-872		Köşe birleştirme aparatı Shoulder aligning square	
D-872-1		Köşe birleştirme aparatı Shoulder aligning square	

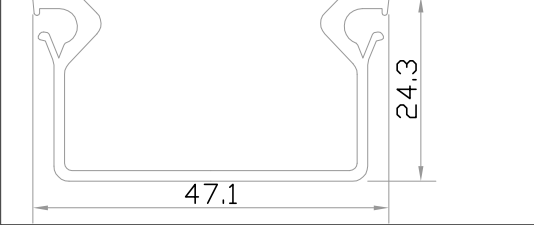
S65-T YALITIMLI SÜRME SERİ
S65 -T INSULATED SLIDING SERIES

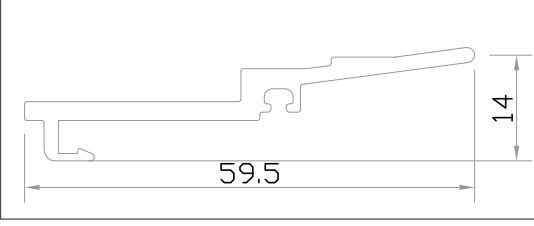
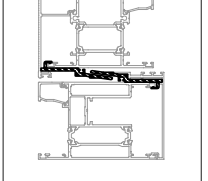
PVC İZALASYON LİSTESİ
PVC İZALATOR LIST

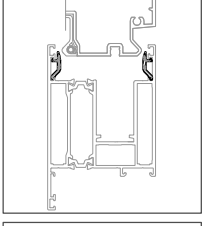
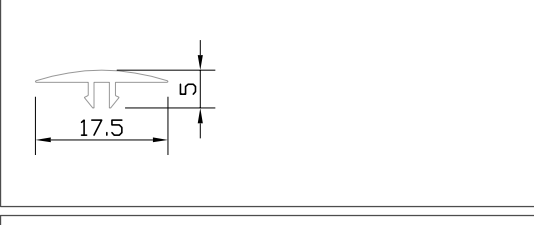
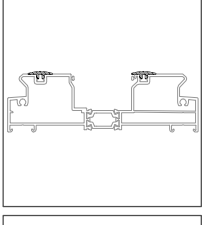
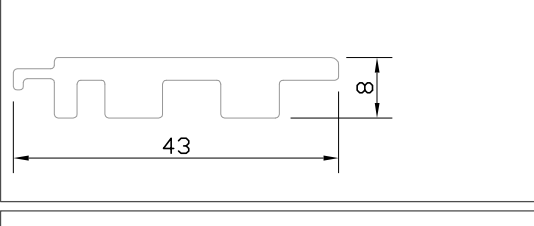
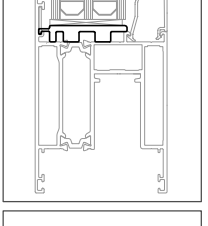
kod code	şekil drawing	tanım description	metraji metre / package	kullanım yeri aplication
S3-840		Kanal U kapama pr. (pvc) U izalator (pvc)	6 m	
S3-841		Adaptör pr. (pvc) Adapter profile (pvc)	6 m	
S3-845		Kanat adaptör pr. (pvc) Sash Adapter profile (pvc)	6 m	
S-843		Kapama pr. (pvc) izalator (pvc)	6 m	
D65-869		Cam altı takozu (pvc) Glass support piece (pvc)	6 m	

S3

S65-T YALITIMLI SÜRME SERİ

S65 -T INSULATED SLIDING SERIES

AÇILIM MEKANİZMALARI
OPENING MECHANISMS

S65 SÜRME SERİ

S65 SLIDE SYSTEM

Max 150 Kg

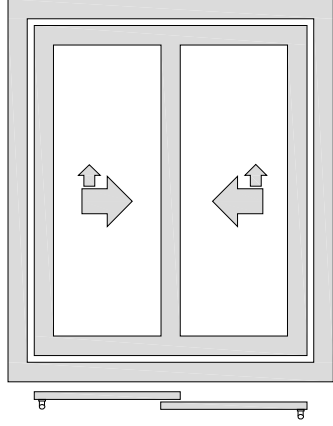

Max 300 Kg

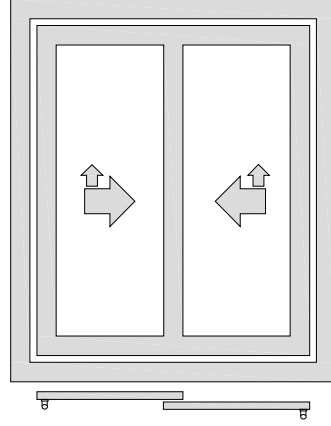

TEK RAY + SABİT KASA

SINGLE RAIL + FIX FRAME

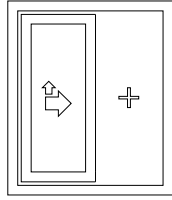
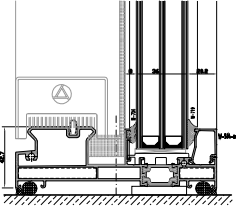

tip-1A

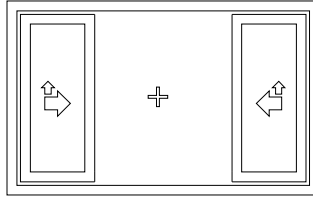

tip-1B

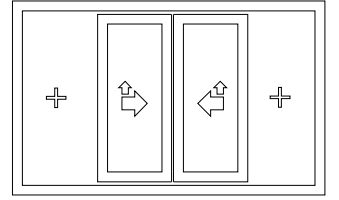

tip-1C

İKİLİ RAY

TWO RAIL

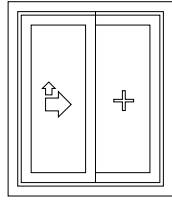
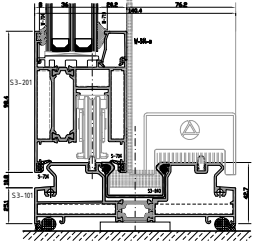

tip-2A

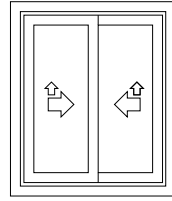

tip-2B

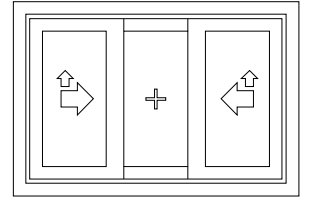

tip-2C

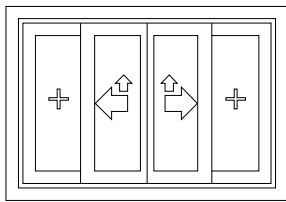

tip-2D

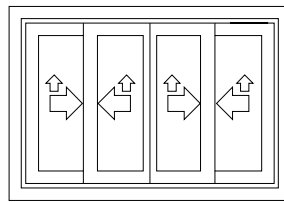

tip-2E

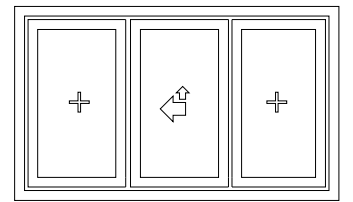

tip-2H

S3

S65-T YALITIMLI SÜRME SERİ S65 -T INSULATED SLIDING SERIES

AÇILIM MEKANİZMALARI
OPENING MECHANISMS

İKİLİ RAY + SABİT KASA TWO RAIL + FIX FRAME

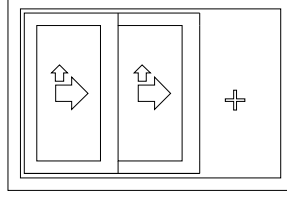
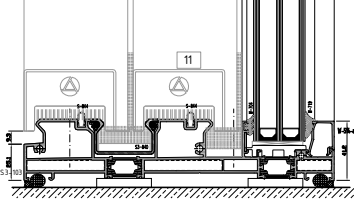

tip-2F

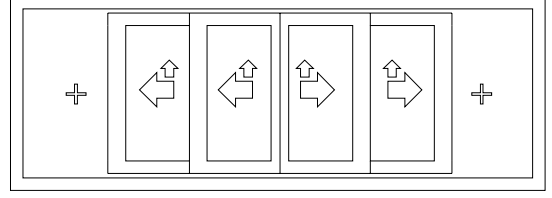

tip-2G

ÜÇLÜ RAY THREE RAIL

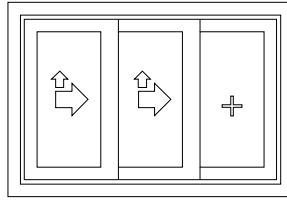
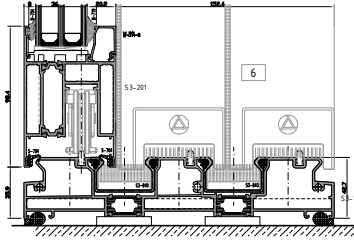

tip-3A

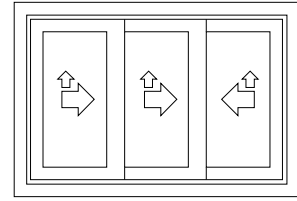

tip-3B

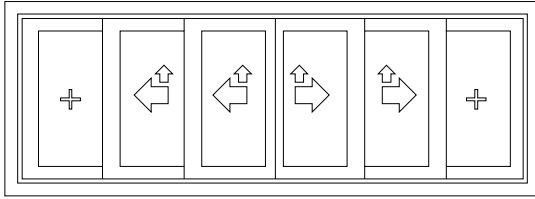

tip-3C

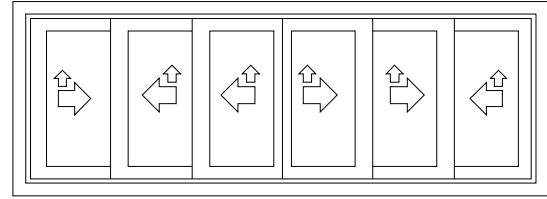

tip-3D

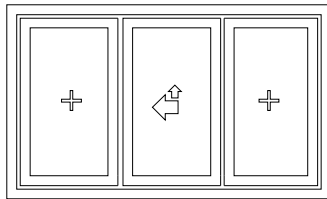

tip-3E

S3

S65-T YALITIMLI SÜRME SERİ

S65 -T INSULATED SLIDING SERIES

AÇILIM MEKANİZMALARI
OPENING MECHANISMS

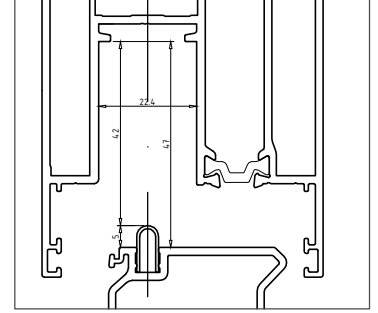

Kaldır-sür mekanizması (max. 150kg)
Lift & sliding mechanism (max. 150kg)

S3-801 (ithal) (import)	S3-801-a (yerli) (native)	naturel eloksalli (mat anodized)
S3-802 (ithal) (import)	S3-802-a (yerli) (native)	pres-renkli boyalı (mat anodized)

TIP - 1 Lift-slide fittings G.U-937 / 150 KG

kanat genişliği w:

yükseklik h:		720-1000	1001-1500	1501-2000	2001-2200
	1800-2300 1A	1	2	3	4
1800-2300 1B	5	6	7	8	
1800-2300 1C	9	10	11	12	

TIP - 2 Lift-slide fittings G.U-937 / 150 KG

kanat genişliği w:

yükseklik h:		720-1000	1001-1500	1501-2000	2001-2200
	1800-2300 2A	13	14	15	16
1800-2300 2B	17	18	19	20	
1800-2300 2C	21	22	23	24	
1800-2300 2D	25	26	27	28	
1800-2300 2E	29	30	31	32	
1800-2300 2F	33	34	35	36	
1800-2300 2G	37	38	39	40	
1800-2300 2H	169	170	171	172	

TIP - 3 Lift-slide fittings G.U-937 / 150 KG

kanat genişliği w:

yükseklik h:		720-1000	1001-1500	1501-2000	2001-2200
	1800-2300 3A	41	42	43	44
1800-2300 3B	45	46	47	48	
1800-2300 3C	49	50	51	52	
1800-2300 3D	53	54	55	56	
1800-2300 3E	173	174	175	176	

(renk seçeneği belirtilmelidir)

(colour choice must be stated)

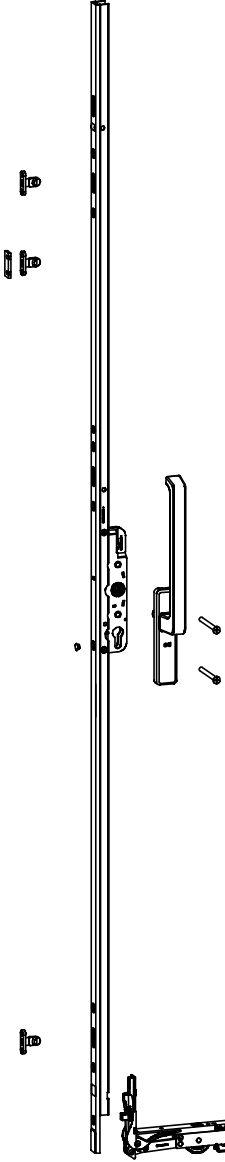

S3

S65-T YALITIMLI SÜRME SERİ S65 -T INSULATED SLIDING SERIES

AÇILIM MEKANİZMALARI
OPENING MECHANISMS

Kaldır-sür mekanizması (max. 300kg)
Lift & sliding mechanism (max. 300kg)

S3-803 (ithal)
(import)

S3-803-a (yerli)
(native)

naturel eloksalli
(mat anodized)

S3-804 (ithal)
(import)

S3-804-a (yerli)
(native)

pres-renkli boyalı
(mat anodized)

TIP - 1 Lift-slide fittings G.U-934 / 300 KG

kanat genişliği w:

		720-1000	1001-1500	1501-2000	2001-2500	2501-3000	3001-3300
yükseklik h:	1800-2300 1A	1	2	3	4	5	6
	2301-2700 1A	7	8	9	10	11	12
	1800-2300 1B	13	14	15	16	17	18
	2301-2700 1B	19	20	21	22	23	24
	1800-2300 1C	25	26	27	28	29	30
	2301-2700 1C	31	32	33	34	35	36

TIP - 2 Lift-slide fittings G.U-934 / 300 KG

kanat genişliği w:

		720-1000	1001-1500	1501-2000	2001-2500	2501-3000	3001-3300
yükseklik h:	1800-2300 2A	37	38	39	40	41	42
	2301-2700 2A	43	44	45	46	47	48
	1800-2300 2B	49	50	51	52	53	54
	2301-2700 2B	55	56	57	58	59	60
	1800-2300 2C	61	62	63	64	65	66
	2301-2700 2C	67	68	69	70	71	72
	1800-2300 2D	73	74	75	76	77	78
	2301-2700 2D	79	80	81	82	83	84
	1800-2300 2E	85	86	87	88	89	90
	2301-2700 2E	91	92	93	94	95	96
	1800-2300 2F	97	98	99	100	101	102
	2301-2700 2F	103	104	105	106	107	108
	1800-2300 2G	109	110	111	112	113	114
	2301-2700 2G	115	116	117	118	119	120
	1800-2300 2H	177	178	179	180	181	182
	2301-2700 2H	183	184	185	186	187	188

TIP - 3 Lift-slide fittings G.U-934 / 300 KG

kanat genişliği w:

		720-1000	1001-1500	1501-2000	2001-2500	2501-3000	3001-3300
yükseklik h:	1800-2300 3A	121	122	123	124	125	126
	2301-2700 3A	127	128	129	130	131	132
	1800-2300 3B	133	134	135	136	137	138
	2301-2700 3B	139	140	141	142	143	144
	1800-2300 3C	145	146	147	148	149	150
	2301-2700 3C	151	152	153	154	155	156
	1800-2300 3D	157	158	159	160	161	162
	2301-2700 3D	163	164	165	166	167	168
	1800-2300 3E	189	190	191	192	193	194
	2301-2700 3E	195	196	197	198	199	200

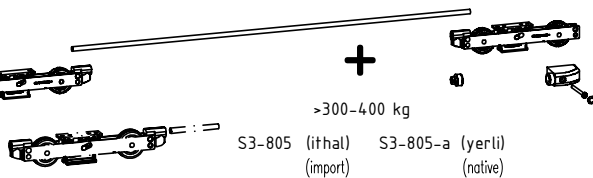
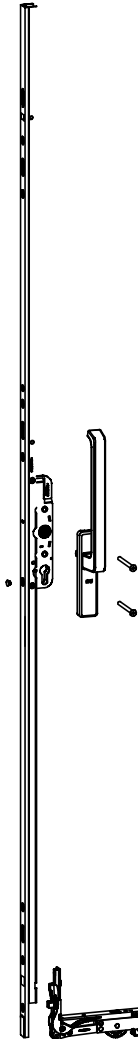

>300-400 kg

S3-805 (ithal)
(import)

S3-805-a (yerli)
(native)

(renk seçeneği belirtilmelidir)

(colour choice must be stated)

S3

S65-T YALITIMLI SÜRME SERİ S65 -T INSULATED SLIDING SERIES

AÇILIM MEKANİZMALARI
OPENING MECHANISMS

Örnek kod tesbiti
Example code key

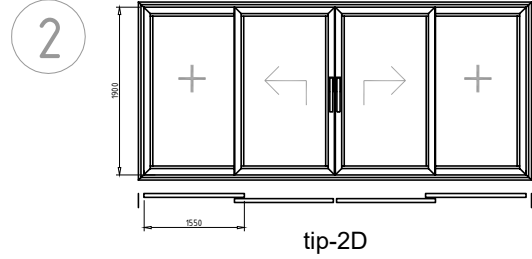
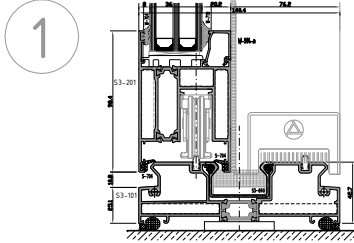

TIP - 2 Lift-slide fittings G.U-937 / 150 KG
kanat genişliği w:

		720-1000	1001-1500	1501-2000	2001-2200
yükseklik h:	1800-2300 2A	13	14	15	16
	1800-2300 2B	17	18	19	20
	1800-2300 2C	21	22	23	24
	1800-2300 2D	25	26	27	28
	1800-2300 2E	29	30	31	32
	1800-2300 2F	33	34	35	36
	1800-2300 2G	37	38	39	40
	1800-2300 2H	169	170	171	172

sipariş kodu
order code

S3-801-27 (ithal)
(import)

S3-801-27-a (yerli)
(native)

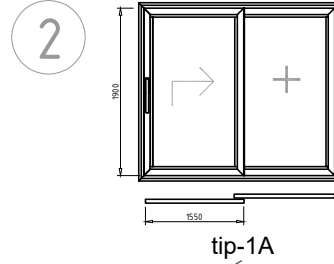
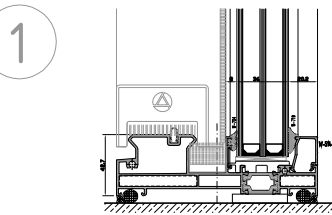

TIP - 1 Lift-slide fittings G.U-934 / 300 KG
kanat genişliği w:

		720-1000	1001-1500	1501-2000	2001-2500	2501-3000	3001-3300
yükseklik h:	1800-2300 1A	1	2	3	4	5	6
	2301-2700 1A	7	8	9	10	11	12
	1800-2300 1B	13	14	15	16	17	18
	2301-2700 1B	19	20	21	22	23	24
	1800-2300 1C	25	26	27	28	29	30
	2301-2700 1C	31	32	33	34	35	36

sipariş kodu
order code

S3-801-3 (ithal)
(import)

S3-801-3-a (yerli)
(native)