

SİLİKON CEPHE
SILICONE FACADE

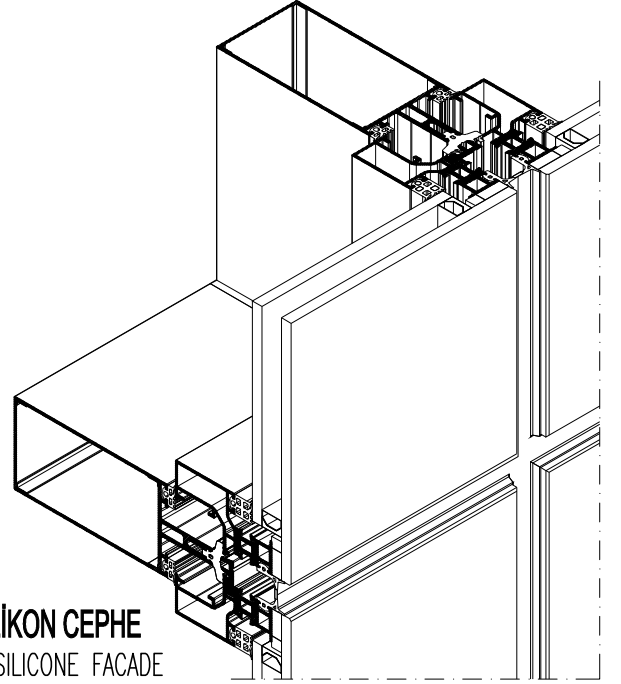

ISI YALITIMLI SİLİKON CEPHE
HEAT INSULATING SILICONE FACADE

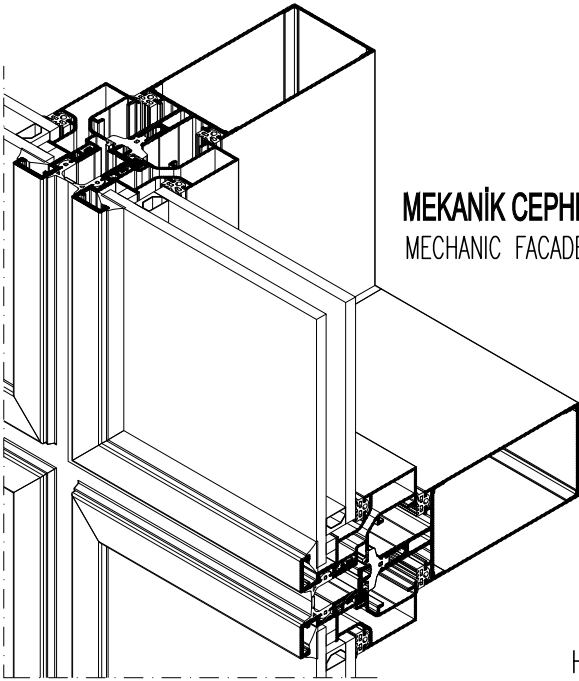

MEKANİK CEPHE
MECHANIC FACADE

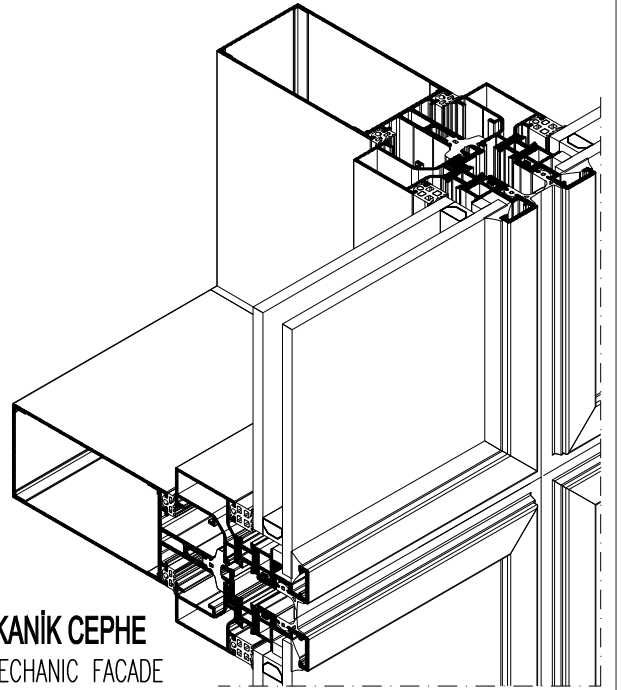







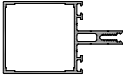
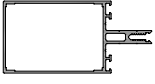

ISI YALITIMLI MEKANİK CEPHE
HEAT INSULATING MECHANIC FACADE

F50 KLASİK SİSTEM
SİLİKON CEPHE
F50 CLASSIC SYSTEM
SILICONE FACADE

F50 KLASİK SİSTEM
SİLİKON CEPHE
F50 CLASSIC SYSTEM
SILICONE FACADE

ÜRÜN TEKNİK ÖZELLİKLERİ
PRODUCT'S TECHNICAL FEATURES

No. Nr.	PROFİL KESİTİ PROFILE VIEW	PROFİL NO PROFILE NO	PROFİL AÇIKLAMASI PROFILE DESCRIPTION	BAĞLANTI PARÇALARI CORNER CLEATS	gr/m	STATİK STATIC			
						Ix cm ⁴	Iy cm ⁴	Wx cm ³	Wy cm ³
1		SC0101 (35 - 50) (14 mm)	TAŞIYICI PROFİL MULLION OR TRANSOM PROFILE	SC0310-1 (26.6 mm) SC0301-1 (26.6 mm) SC0302-1 (26.6 mm) SC0316-0 (26.6 mm)	1155	14.17	10.10	4.09	4.04
2		SC0102 (55 - 50) (14 mm)	TAŞIYICI PROFİL MULLION OR TRANSOM PROFILE	SC0310-2 (46.4 mm) SC0301-2 (46.4 mm) SC0302-2 (46.4 mm) SC0316-1 (46.4 mm)	1332	30.95	13.58	7.36	5.43
3		SC0103 (75 - 50) (14 mm)	TAŞIYICI PROFİL MULLION OR TRANSOM PROFILE	SC0310-3 (66.4 mm) SC0301-3 (66.4 mm) SC0302-3 (66.4 mm) SC0316-2 (66.4 mm)	1484	57.03	16.89	10.77	6.76
4		SC0104 (95 - 50) (14 mm)	TAŞIYICI PROFİL MULLION OR TRANSOM PROFILE	SC0310-4 (86.4 mm) SC0301-4 (86.4 mm) SC0302-4 (86.4 mm) SC0316-3 (86.4 mm)	1635	93.67	20.20	14.49	8.08
5		SC0105 (115 - 50) (14 mm)	TAŞIYICI PROFİL MULLION OR TRANSOM PROFILE	SC0310-5 (106 mm) SC0301-5 (106 mm) SC0302-5 (106 mm) SC0316-4 (106 mm)	1838	152.24	23.86	20.58	9.54
6		SC0106 (135 - 50) (14 mm)	TAŞIYICI PROFİL MULLION OR TRANSOM PROFILE	SC0310-6 (126 mm) SC0301-6 (126 mm) SC0302-6 (126 mm) SC0316-5 (126 mm)	2132	223.87	30.40	26.73	12.02
7		SC0107 (155 - 50) (17 mm)	TAŞIYICI PROFİL MULLION OR TRANSOM PROFILE	SC0310-7 (146 mm) SC0301-7 (146 mm) SC0302-7 (146 mm) SC0316-6 (146 mm)	2383	312.21	35.36	33.25	14.14
8		SC0108 (175 - 50) (18 mm)	TAŞIYICI PROFİL MULLION OR TRANSOM PROFILE	SC0310-8 (166 mm) SC0301-8 (166 mm) SC0302-8 (166 mm) SC0316-7 (166 mm)	2658	423.36	41.12	40.77	16.45
9		SC0109 (195 - 50) (18 mm)	TAŞIYICI PROFİL MULLION OR TRANSOM PROFILE	SC0310-9 (186 mm) SC0301-9 (186 mm) SC0302-9 (186 mm) SC0316-8 (186 mm)	3225	615.02	51.02	54.97	20.41
10		SC0110 (35 - 50) (2 mm)	TAŞIYICI PROFİL MULLION OR TRANSOM PROFILE	SC0310-1 (26.6 mm) SC0301-1 (26.6 mm) SC0302-1 (26.6 mm) SC0316-0 (26.6 mm)	1325	15.93	11.84	4.39	4.73







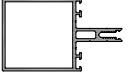

 İşaretili profil için satış ekibinden bilgi alınır.

Profil değerleri teoriktir. Ağırlık olarak testimde yapılan tartım geçerlidir.
Profil imalatları TS EN 12020-2 ve TS EN 755-9 toleransları,
Moment değerleri EN 14024'e göre hesaplanmıştır.

Profile values are theoretical pre-shipment weight will be valid.
The tolerances of Profile manufacturing are calculated according to EN 12020-2
and TS EN 755-9; moment values are calculated according to EN 14024.

F50 KLASİK SİSTEM
SİLİKON CEPHE
F50 CLASSIC SYSTEM
SILICONE FACADE

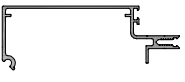
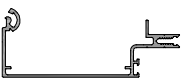
ÜRÜN TEKNİK ÖZELLİKLERİ
PRODUCT'S TECHNICAL FEATURES









No. Nr.	PROFİL KESİTİ PROFILE VIEW	PROFİL NO PROFILE NO	PROFİL AÇIKLAMASI PROFILE DESCRIPTION	BAĞLANTI PARÇALARI CORNER CLEATS	gr/m	STATİK STATIC			
						Ix cm ⁴	Iy cm ⁴	Wx cm ³	Wy cm ³
11		SC0111 (55 - 50) (2 mm)	TAŞIYICI PROFİL MULLION OR TRANSOM PROFILE	SC0310-2 (46.4 mm) SC0301-2 (46.4 mm) SC0302-2 (46.4 mm) SC0316-1 (46.4 mm)	1567	35.63	16.62	8.03	6.65
12		SC0112 (75 - 50) (2 mm)	TAŞIYICI PROFİL MULLION OR TRANSOM PROFILE	SC0310-3 (66.4 mm) SC0301-3 (66.4 mm) SC0302-3 (66.4 mm) SC0316-2 (66.4 mm)	1783	66.57	21.23	12.58	8.49
13		SC0113 (95 - 50) (2 mm)	TAŞIYICI PROFİL MULLION OR TRANSOM PROFILE	SC0310-4 (86.4 mm) SC0301-4 (86.4 mm) SC0302-4 (86.4 mm) SC0316-3 (86.2 mm)	2000	110.45	25.84	17.88	10.34
14		SC0114 (115 - 50) (2 mm)	TAŞIYICI PROFİL MULLION OR TRANSOM PROFILE	SC0310-5 (106 mm) SC0301-5 (106 mm) SC0302-5 (106 mm) SC0316-4 (106 mm)	2267	177.74	30.77	25.55	12.31
15		SC0115 (135 - 50) (2 mm)	TAŞIYICI PROFİL MULLION OR TRANSOM PROFILE	SC0310-6 (126 mm) SC0301-6 (126 mm) SC0302-6 (126 mm) SC0316-5 (126 mm)	2484	255.44	35.39	31.25	14.15
16		SC0116 (155 - 50) (2 mm)	TAŞIYICI PROFİL MULLION OR TRANSOM PROFILE	SC0310-7 (146 mm) SC0301-7 (146 mm) SC0302-7 (146 mm) SC0316-6 (146 mm)	2700	315.36	39.99	38.30	16.00
17		SC0117 (175 - 50) (2 mm)	TAŞIYICI PROFİL MULLION OR TRANSOM PROFILE	SC0310-8 (166 mm) SC0301-8 (166 mm) SC0302-8 (166 mm) SC0316-7 (166 mm)	2917	467.15	44.60	45.71	17.84
18	 ⚠ İşaretili profil için satış ekibinden bilgi alınız.	SC0121-A (95 - 44) (15 mm)	TAŞIYICI PROFİL MULLION PROFILE		1262	92.06	7.97	14.77	2.80
19	 ⚠ İşaretili profil için satış ekibinden bilgi alınız.	SC0121-B (95 - 48) (15 mm)	TAŞIYICI PROFİL MULLION PROFILE		1351	100.05	9.84	15.23	3.25
20		SC0122-A (115 - 44) (15 mm)	TAŞIYICI PROFİL MULLION PROFILE		1344	135.18	8.61	18.89	2.92

Profil değerleri teoriktir. Ağırlık olarak testimde yapılan tartım geçerlidir.
Profil imalatları TS EN 12020-2 ve TS EN 755-9 toleransı,
Moment değerleri EN 14024'e göre hesaplanmıştır.

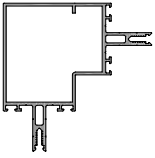
Profile values are theoretical pre-shipment weight will be valid.
The tolerances of Profile manufacturing are calculated according to EN 12020-2
and TS EN 755-9; moment values are calculated according to EN 14024.

F50 KLASİK SİSTEM
SİLİKON CEPHE
F50 CLASSIC SYSTEM
SILICONE FAÇADE

ÜRÜN TEKNİK ÖZELLİKLERİ
PRODUCT'S TECHNICAL FEATURES

No. Nr.	PROFİL KESİTİ PROFILE VIEW	PROFİL NO PROFILE NO	PROFİL AÇIKLAMASI PROFILE DESCRIPTION	BAĞLANTI PARÇALARI CORNER CLEATS	gr/m	STATİK STATIC			
						Ix cm ⁴	Iy cm ⁴	Wx cm ³	Wy cm ³
21		SC0122-B (115 - 48) (15 mm)	TAŞIYICI PROFİL MULLION PROFILE		1432	147.01	10.62	19.55	3.40
22		SC0124-A (155 - 44.3) (18 mm)	TAŞIYICI PROFİL MULLION PROFILE		1645	265.39	10.62	28.92	3.37
23		SC0124-B (155 - 47) (18 mm)	TAŞIYICI PROFİL MULLION PROFILE		1785	297.01	13.56	30.26	4.20
24		SC0127 (75 - 75) (14 mm)	TAŞIYICI PROFİL MULLION PROFILE	SC0316-2 (66.4 mm)	2579				
25		SC0201 (34.9 - 49.5) (13 mm)	ÇİFT CAM PANEL PROFİLİ PANEL PROFILE FOR DOUBLE GLASS	SC0308-a (25,68 mm) SC0307-a (10,25 mm) SC0304-a (50 mm)	734				
26		SC0202 (34.9 - 49.5) (13 mm)	TEK CAM PANEL PROFİLİ PANEL PROFILE FOR SINGLE GLASS	SC0308-a (25,68 mm) SC0307-a (10,25 mm) SC0304-a (50 mm)	636				
27		SC0203 (34.9 - 57) (13 mm)	KOMPOZİT PANEL PROFİLİ PANEL PROFILE FOR COMPOSITE	SC0308-a (25,68 mm) SC0307-a (10,25 mm) SC0304-a (50 mm)	643				
28		SC0204 (34.9 - 59.6) (13 mm)	ÇİFT CAM PANEL PROFİLİ PANEL PROFILE FOR DOUBLE GLASS	SC0308-b (29,74 mm) SC0309-a (6,5 mm) SC0304-a (50 mm)	PVC 970 POLYAMİD 963				
29		SC0205 (34.9 - 59.6) (13 mm)	TEK CAM PANEL PROFİLİ PANEL PROFILE FOR SINGLE GLASS	SC0308-b (29,74 mm) SC0309-a (6,5 mm) SC0304-a (50 mm)	PVC 894 POLYAMİD 886				
30		SC0206 (34.9 - 59.1) (13 mm)	KOMPOZİT PANEL PROFİLİ PANEL PROFILE FOR COMPOSITE	SC0308-b (29,74 mm) SC0309-a (6,5 mm) SC0304-a (50 mm)	PVC 924 POLYAMİD 917				

Profil değerleri teoriktir. Ağırlık olarak testimde yapılan tartım geçerlidir.
Profil imalatları TS EN 12020-2 ve TS EN 755-9 toleransı,
Moment değerleri EN 14024'e göre hesaplanmıştır.

Profile values are theoretical pre-shipment weight will be valid.
The tolerances of Profile manufacturing are calculated according to EN 12020-2
and TS EN 755-9; moment values are calculated according to EN 14024.

F50 KLASİK SİSTEM
SİLİKON CEPHE
F50 CLASSIC SYSTEM
SILICONE FACADE

ÜRÜN TEKNİK ÖZELLİKLERİ
PRODUCT'S TECHNICAL FEATURES











No. Nr.	PROFİL KESİTİ PROFILE VIEW	PROFİL NO PROFILE NO	PROFİL AÇIKLAMASI PROFILE DESCRIPTION	BAĞLANTI PARÇALARI CORNER CLEATS	gr/m	STATİK STATIC			
						Ix cm ⁴	Iy cm ⁴	Wx cm ³	Wy cm ³
31		SC0207 (19,1 - 4,9) (15 mm)	SİLİKON YAPIŞTIRMA PR. SILICONE BONDING PROFILE		109				
32		SC0209 (22,1 - 49,5) (13 mm)	BITİM PROFİLİ COMPLETION PROFILE	SC0307-a (10,25 mm) SC0304-a (50 mm)	593				
33		SC0210 (36,1 - 50,5) (2 mm)	ÇİFT CAM PANEL PROFİLİ PANEL PROFILE FOR DOUBLE GLASS	SC0308-a (25,68 mm) SC0307-a (10,25 mm) SC0304-a (50 mm)	1001				
34		SC0214 (36,1 - 61,1) (2 mm)	ÇİFT CAM PANEL PROFİLİ PANEL PROFILE FOR DOUBLE GLASS	SC0308-b (29,74 mm) SC0309-a (6,5 mm) SC0304-a (50 mm)	PVC 1275 POLYAMİD 1268				
35		SC0215 (33,2 - 73,1) (2 mm)	ÇİFT CAM PANEL PROFİLİ PANEL PROFILE FOR DOUBLE GLASS	SC0308-b (29,74 mm) SC0309-a (6,5 mm) SC0304-a (50 mm)	PVC 1365 POLYAMİD 1350				
36		SC0216 (32 - 71,6) (13 mm)	TEK CAM PANEL PROFİLİ PANEL PROFILE FOR SINGLE GLASS	SC0308-b (29,74 mm) SC0309-a (6,5 mm) SC0304-a (50 mm)	PVC 1060 POLYAMİD 1045				
37		SC0218 (33,5 - 64,5) (13 mm)	ÇİFT CAM PANEL PROFİLİ PANEL PROFILE FOR DOUBLE GLASS	SC0308-b (29,74 mm) SC0308-g (19,5 mm) SC0304-a (50 mm)	1241				
38		SC0217 (13,8 - 27,9) (13 mm)	BITİM PROFİLİ COMPLETION PROFILE	SC0304-a (50 mm)	242				
39		SC0301 (6,2 - 35,3) (5 mm)	KIRLANGIÇ GEÇME PROFİLİ T-CONNECTOR FOR TRANSOM PROFILE		470				
40		SC0302 (29,8 - 45,7) (2 mm)	KIRLANGIÇ GEÇME PROFİLİ T-CONNECTOR FOR TRANSOM PROFILE		1002				

Profil değerleri teoriktir. Ağırlık olarak testimde yapılan tartım geçerlidir.
Profil imalatları TS EN 12020-2 ve TS EN 755-9 toleransları,
Moment değerleri EN 14024'e göre hesaplanmıştır.

Profile values are theoretical pre-shipment weight will be valid.
The tolerances of Profile manufacturing are calculated according to EN 12020-2
and TS EN 755-9; moment values are calculated according to EN 14024.

**F50 KLASİK SİSTEM
SİLİKON CEPHE**
F50 CLASSIC SYSTEM
SILICONE FACADE

ÜRÜN TEKNİK ÖZELLİKLERİ
PRODUCT'S TECHNICAL FEATURES

No. Nr.	PROFİL KESİTİ PROFILE VIEW	PROFİL NO PROFILE NO	PROFİL AÇIKLAMASI PROFILE DESCRIPTION	BAĞLANTI PARÇALARI CORNER CLEATS	gr/m	STATİK STATIC			
						Ix cm ⁴	Iy cm ⁴	Wx cm ³	Wy cm ³
41		SC0304 (19 - 7.6) (2.8 mm)	DIŞTAN BAĞLANTI PROFİLİ OUTSIDE CONNECTION PROFILE		250				
42		SC0307 (55 - 55) (9.71 mm)	KÖŞE BİRLEŞTİRME PROFİLİ CORNER CLEATS PROFILE		1737				
43		SC0308 (55 - 55) (11.82 mm)	KÖŞE BİRLEŞTİRME PROFİLİ CORNER CLEATS PROFILE		2313				
44		SC0309 (55 - 55) (6.9 mm)	KÖŞE BİRLEŞTİRME PROFİLİ CORNER CLEATS PROFILE		1573				
45		SC0310 (31.2 - 45.7) (2.2 mm)	KLASİK TAŞIYICI BAĞ. PR. T-CONNECTOR FOR TRANSOM PROFILE		821				
46		SC0312 (25.1 - 4.2) (2 mm)	CAM OTURTMA PROFİLİ GLAZING SUPPORT FOR SASH PROFILE		147				
47		SC0316 (14.0 - 45.7) (1.9 mm)	DİLATASYON PROFİLİ DILATATION PROFILE		3079				
48		SC0343 (12.1 - 21.7) (1.8 mm)	İÇTEN BAĞLANTI PROFİLİ INSIDE CONNECTION PROFILE		173				
49		SC0344 (15 - 25.4) (2 mm)	İÇTEN BAĞLANTI PROFİLİ INSIDE CONNECTION PROFILE		244				
50		SC0350 (23.2 - 6.7) (1.2 mm)	CAM OTURTMA PROFİLİ GLAZING SUPPORT FOR SASH PROFILE		140				

Profil değerleri teoriktir. Ağırlık olarak testimde yapılan tartım geçerlidir.
Profil imatları TS EN 12020-2 ve TS EN 755-9 toleransı,
Moment değerleri EN 14024'e göre hesaplanmıştır.

Profile values are theoretical pre-shipment weight will be valid.
The tolerances of Profile manufacturing are calculated according to EN 12020-2
and TS EN 755-9; moment values are calculated according to EN 14024.

**F50 KLASİK SİSTEM
SİLİKON CEPHE**
F50 CLASSIC SYSTEM
SILICONE FACADE

ÜRÜN TEKNİK ÖZELLİKLERİ
PRODUCT'S TECHNICAL FEATURES

No. Nr.	PROFİL KESİTİ PROFILE VIEW	PROFİL NO PROFILE NO	PROFİL AÇIKLAMASI PROFILE DESCRIPTION	BAĞLANTI PARÇALARI CORNER CLEATS	gr/m	STATİK STATIC			
						Ix cm ⁴	Iy cm ⁴	Wx cm ³	Wy cm ³
51		MC0201 (20 - 35.5) (2 mm)	TIRNAK ADAPTÖR PROFİLİ CLAW ADAPTER PROFILE		397				
52		MC0202 (18 - 31.5) (2 mm)	TIRNAK ADAPTÖR PROFİLİ CLAW ADAPTER PROFILE		378				
53		SC0346 (8.9 - 31.3) (1 mm)	TAŞIYICI DİLATASYON PR. DILATATION PLASTIC PR. FOR MULLION		120				
54		SC0303 (4.4 - 19.5) (15 mm)	TİJ PROFİLİ PUSHING ROD PROFILE		96				
55									
56									
57									
58									
59									
60									

Profil değerleri teoriktir. Ağırlık olarak teslimde yapılan tartım geçerlidir.
Profil imalatları TS EN 12020-2 ve TS EN 755-9 toleransı,
Moment değerleri EN 14024'e göre hesaplanmıştır.

Profile values are theoretical pre-shipment weight will be valid.
The tolerances of Profile manufacturing are calculated according to EN 12020-2
and TS EN 755-9; moment values are calculated according to EN 14024.

F50 KLASİK SİSTEM SİLİKON CEPHE PROFİLLERİ

F50 CONDENSAT SYSTEM
SILICONE FACADE PROFILE

ÜRÜN TEKNİK ÖZELLİKLERİ
PRODUCT'S TECHNICAL FEATURES

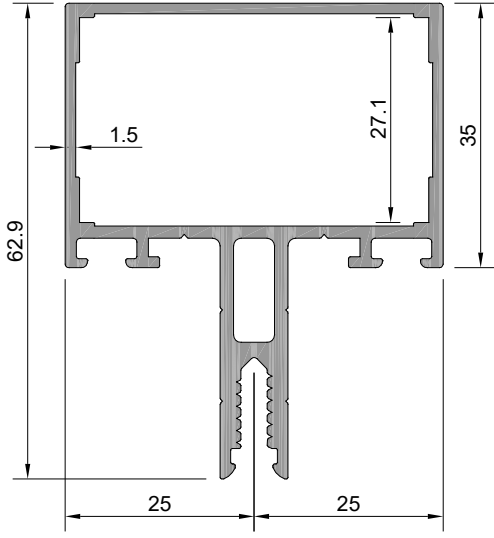

Profil No: SC0101

Ağırlık : 1155 gr/m

I_x : 14,17 cm^4

I_y : 10,10 cm^4

w_x : 4,09 cm^3

w_y : 4,04 cm^3



SC0310-1



SC0301-1



SC0302-1

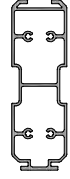

SC0316-0

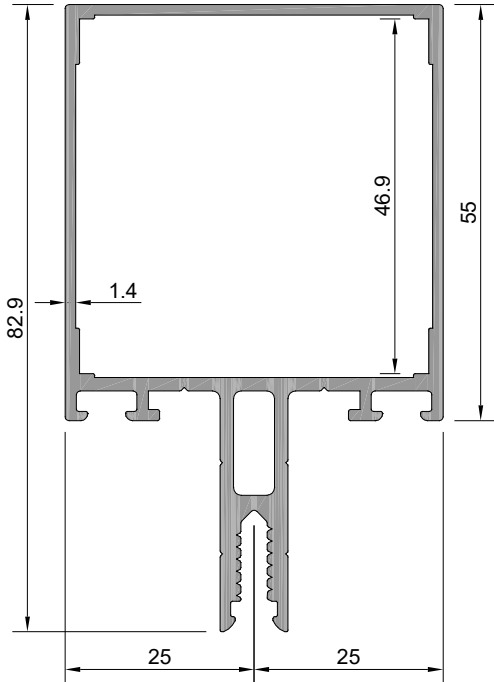

Profil No: SC0102

Ağırlık : 1332 gr/m

I_x : 30,95 cm^4

I_y : 13,58 cm^4

w_x : 7,36 cm^3

w_y : 5,43 cm^3



SC0310-2



SC0301-2



SC0302-2

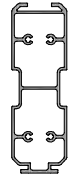

SC0316-1

F50 KLASİK SİSTEM SİLİKON CEPHE PROFİLLERİ

F50 CONDENSAT SYSTEM
SILICONE FACADE PROFILE

ÜRÜN TEKNİK ÖZELLİKLERİ
PRODUCT'S TECHNICAL FEATURES

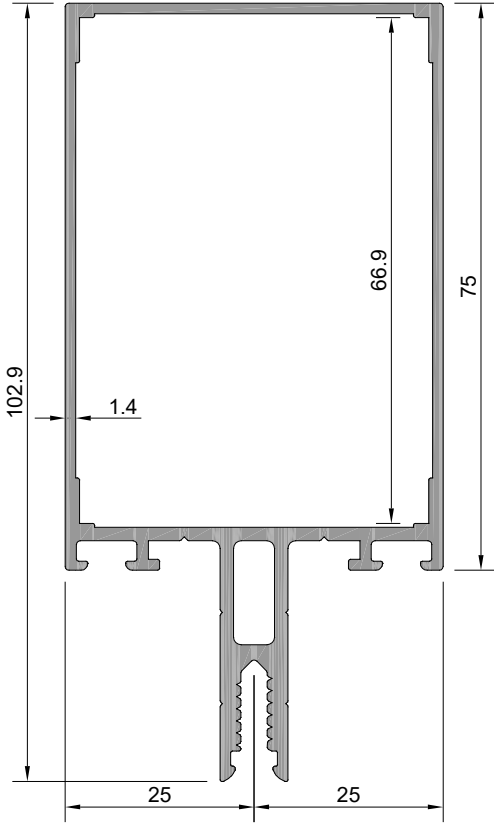

Profil No: SC0103
Ağırlık : 1484 gr/m
Ix : 57,03 cm⁴
Iy : 16,89 cm⁴
wx : 10,77 cm³
wy : 6,76 cm³



SC0310-3



SC0301-3



SC0302-3

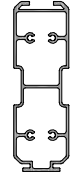

SC0316-2

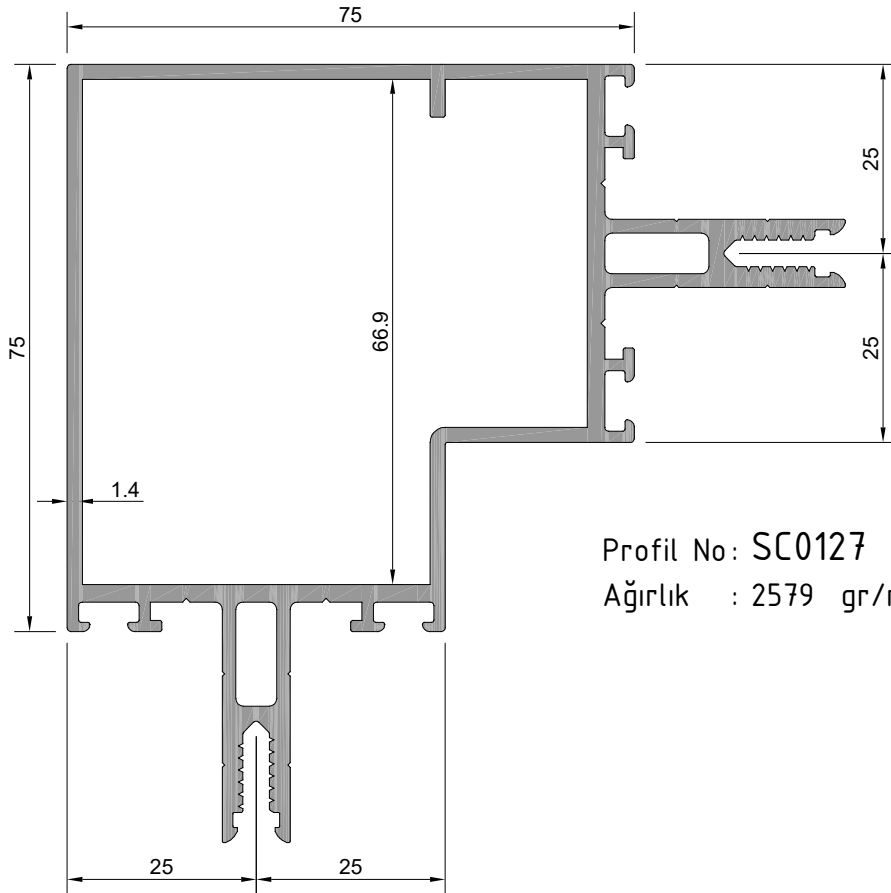

Profil No: SC0127
Ağırlık : 2579 gr/m



SC0310-3



SC0301-3



SC0302-3

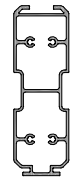

SC0316-2

F50 KLASİK SİSTEM SİLİKON CEPHE PROFİLLERİ

F50 CONDENSAT SYSTEM
SILICONE FACADE PROFILE

ÜRÜN TEKNİK ÖZELLİKLERİ
PRODUCT'S TECHNICAL FEATURES

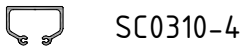
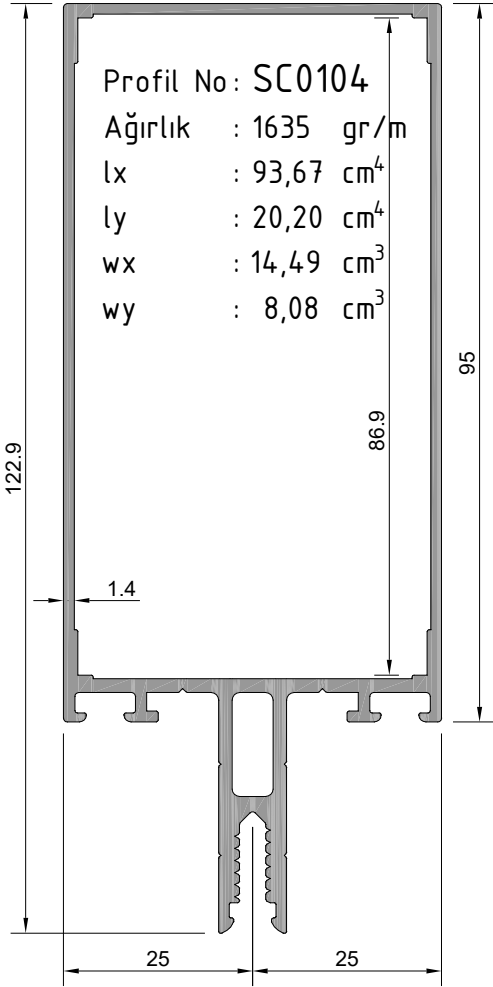

SC0310-4

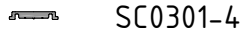

SC0301-4

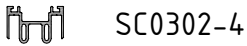

SC0302-4

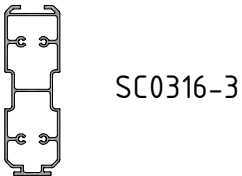

SC0316-3

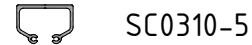
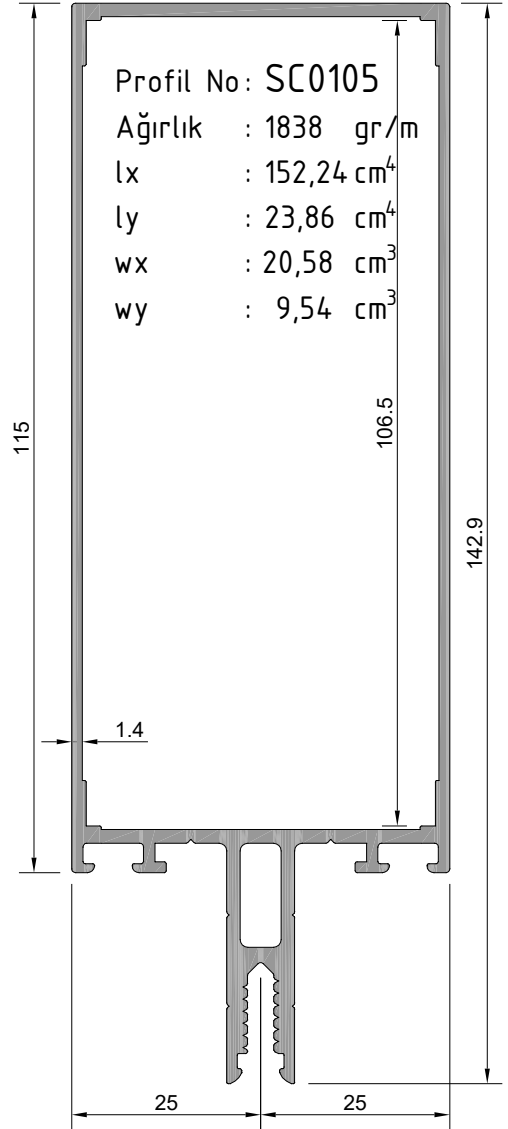

SC0310-5

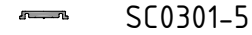

SC0301-5

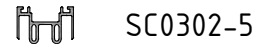

SC0302-5

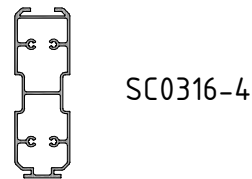

SC0316-4

F50 KLASİK SİSTEM SİLİKON CEPHE PROFİLLERİ

F50 CONDENSAT SYSTEM
SILICONE FACADE PROFILE

ÜRÜN TEKNİK ÖZELLİKLERİ
PRODUCT'S TECHNICAL FEATURES

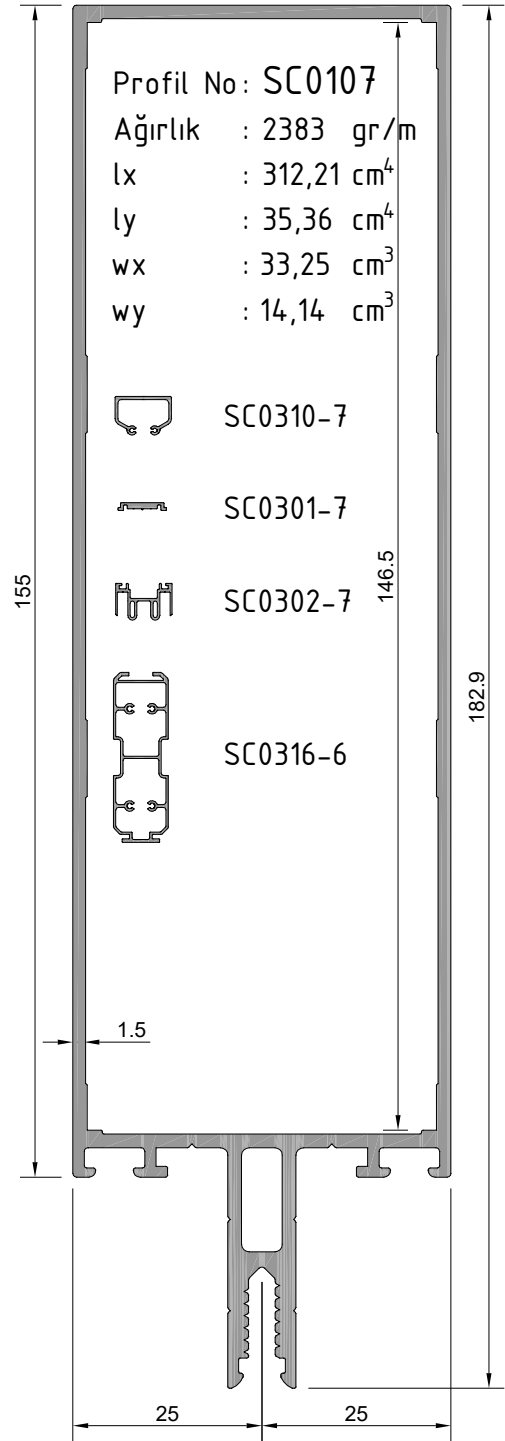
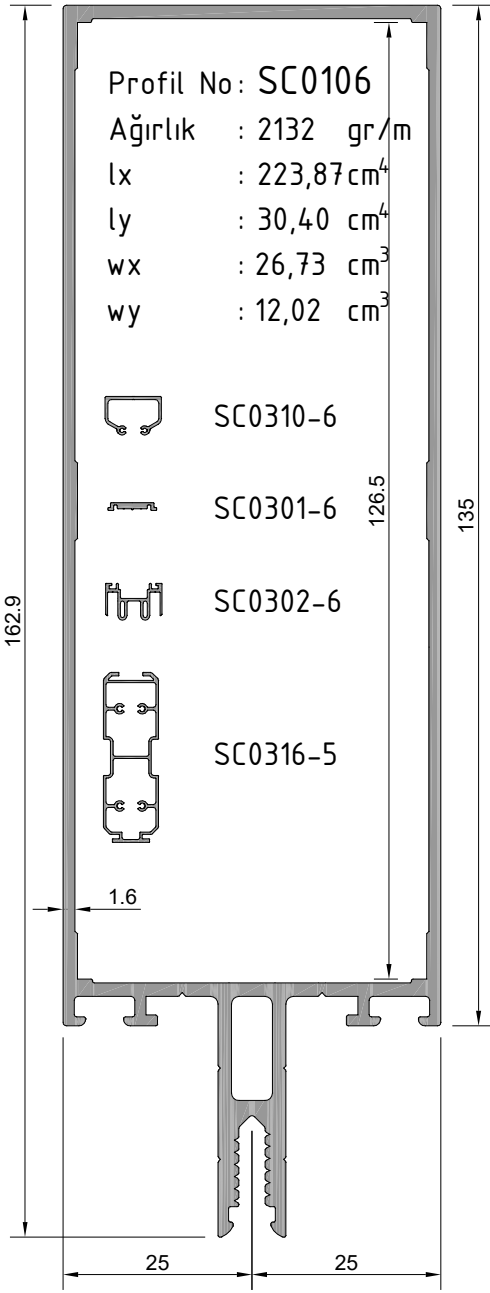

F50 KLASİK SİSTEM SİLİKON CEPHE PROFİLLERİ

F50 CONDENSAT SYSTEM
SILICONE FACADE PROFILE

ÜRÜN TEKNİK ÖZELLİKLERİ
PRODUCT'S TECHNICAL FEATURES

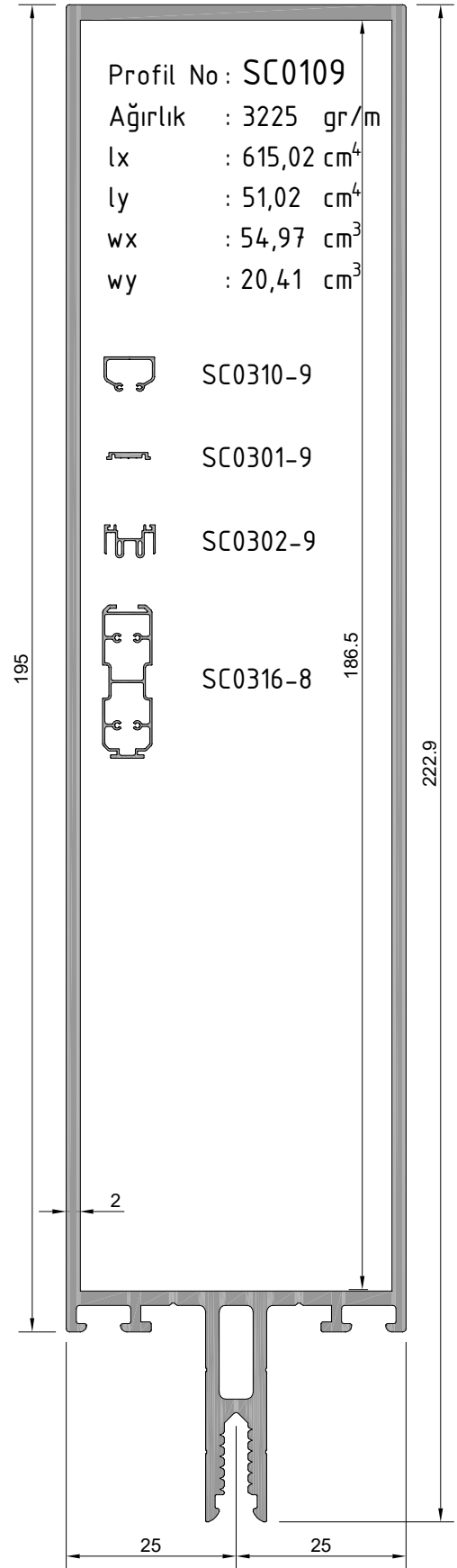
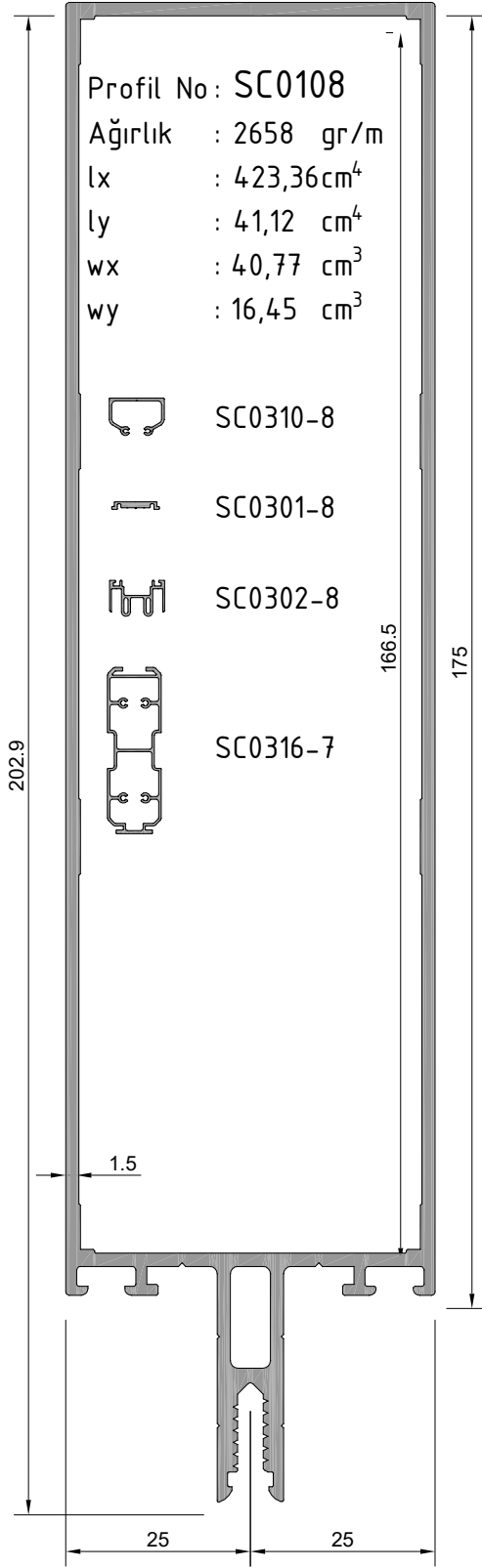

F50 KLASİK SİSTEM SİLİKON CEPHE PROFİLLERİ

F50 CONDENSAT SYSTEM
SILICONE FACADE PROFILE

ÜRÜN TEKNİK ÖZELLİKLERİ
PRODUCT'S TECHNICAL FEATURES

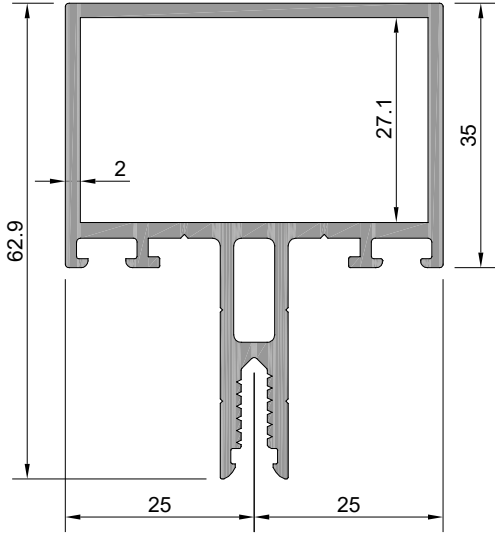

Profil No: SC0110

Ağırlık : 1325 gr/m

I_x : 15,93 cm⁴

I_y : 11,84 cm⁴

w_x : 4,39 cm³

w_y : 4,73 cm³



SC0310-1



SC0301-1



SC0302-1



SC0316-0

İşaretili profil için satış ekibinden bilgi alınız.

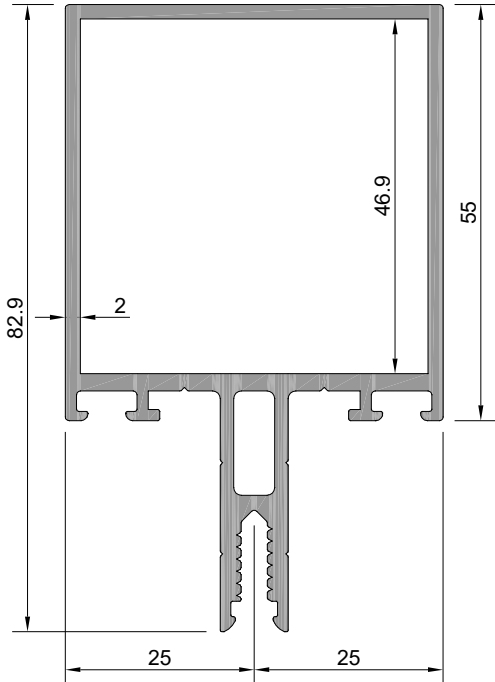

Profil No: SC0111

Ağırlık : 1567 gr/m

I_x : 35,63 cm⁴

I_y : 16,62 cm⁴

w_x : 8,03 cm³

w_y : 6,65 cm³



SC0310-2



SC0301-2



SC0302-2



SC0316-1

F50 KLASİK SİSTEM SİLİKON CEPHE PROFİLLERİ

F50 CONDENSAT SYSTEM
SILICONE FACADE PROFILE

ÜRÜN TEKNİK ÖZELLİKLERİ
PRODUCT'S TECHNICAL FEATURES

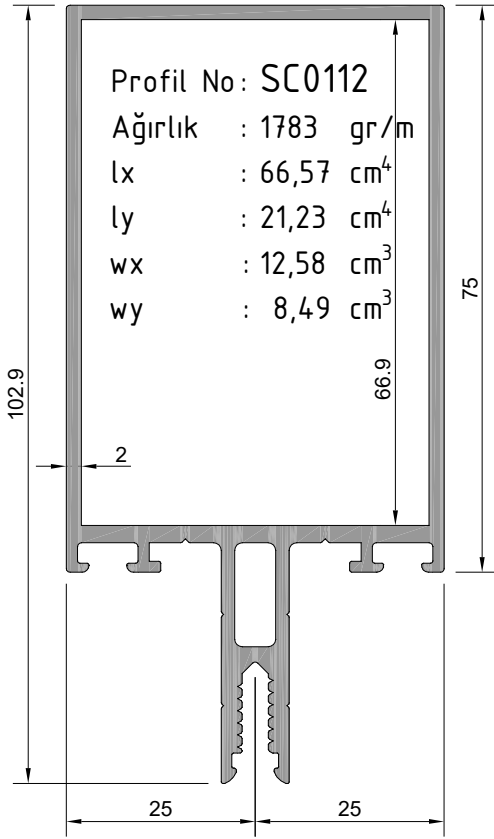

SC0310-3



SC0301-3



SC0302-3

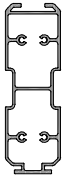

SC0316-2

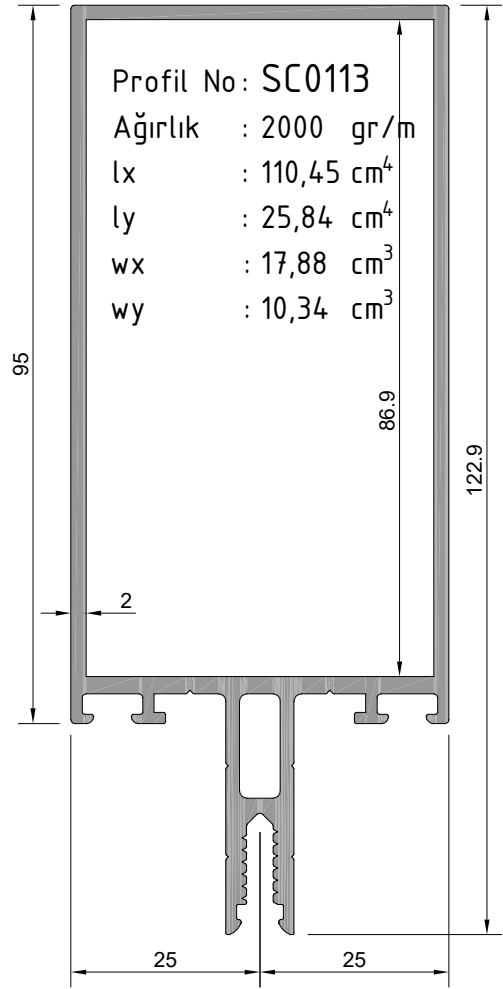

SC0310-4



SC0301-4



SC0302-4

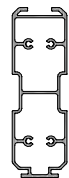

SC0316-3

F50 KLASİK SİSTEM SİLİKON CEPHE PROFİLLERİ

F50 CONDENSAT SYSTEM
SILICONE FACADE PROFILE

ÜRÜN TEKNİK ÖZELLİKLERİ
PRODUCT'S TECHNICAL FEATURES

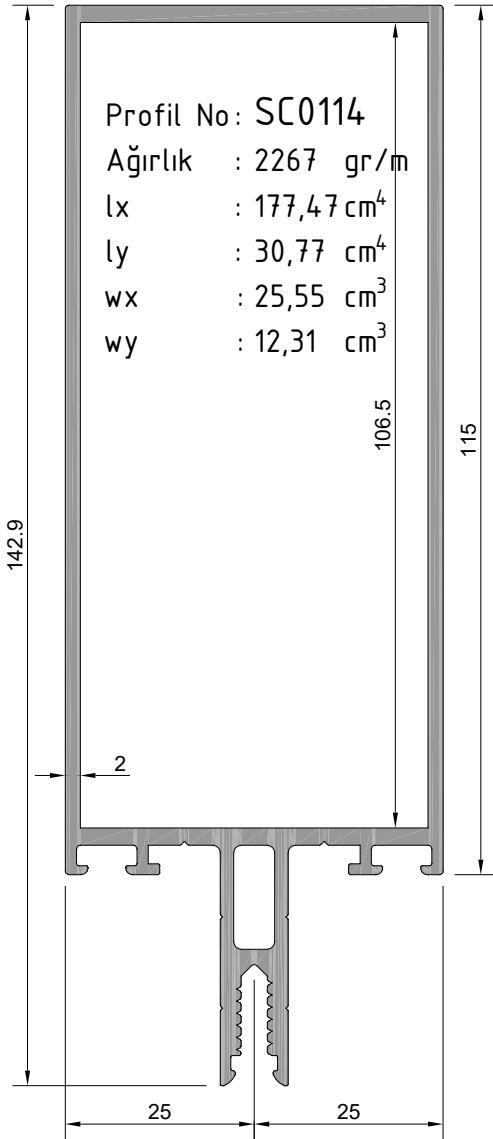

SC0310-5



SC0301-5



SC0302-5

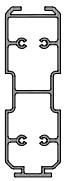

SC0316-4

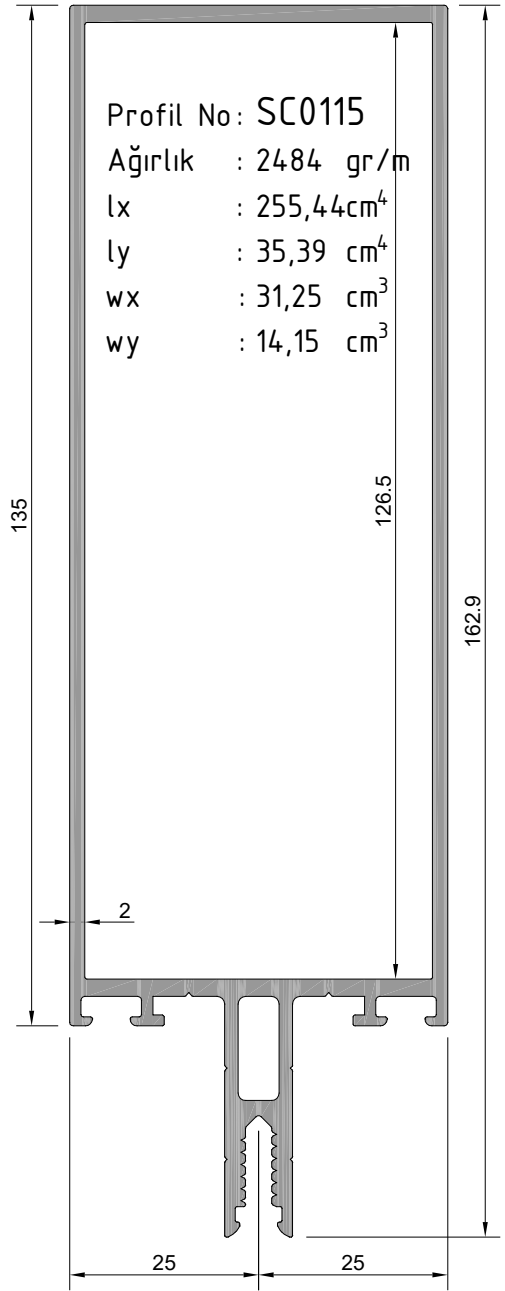

SC0310-6



SC0301-6



SC0302-6



SC0316-5

F50 KLASİK SİSTEM SİLİKON CEPHE PROFİLLERİ

F50 CONDENSAT SYSTEM
SILICONE FACADE PROFILE

ÜRÜN TEKNİK ÖZELLİKLERİ
PRODUCT'S TECHNICAL FEATURES

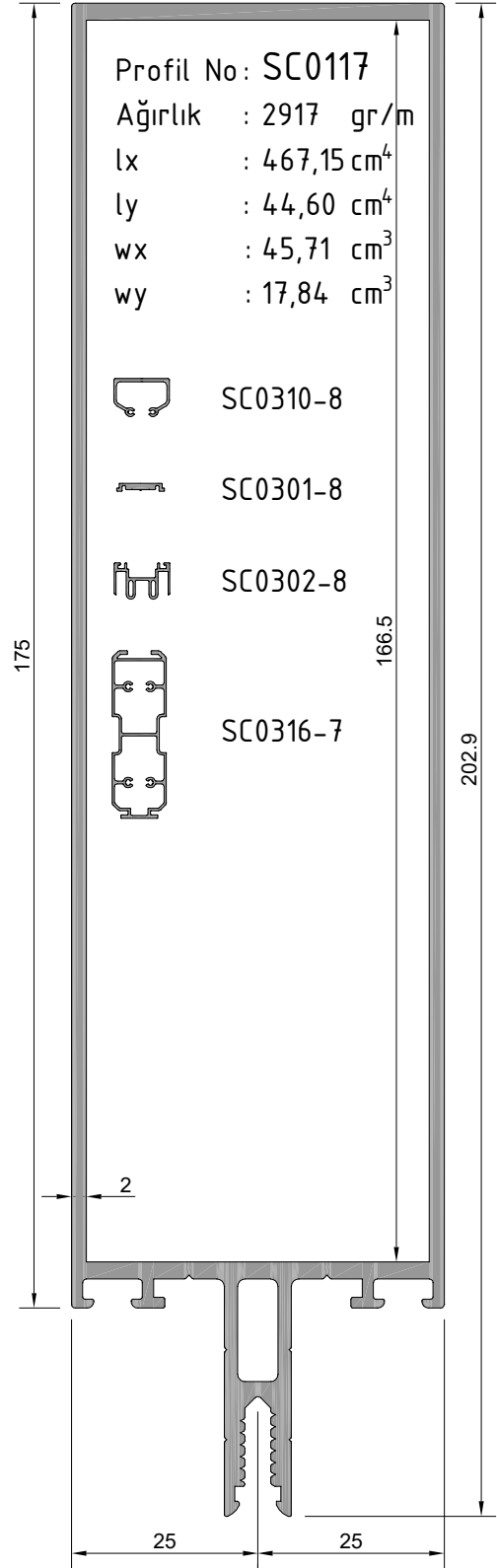
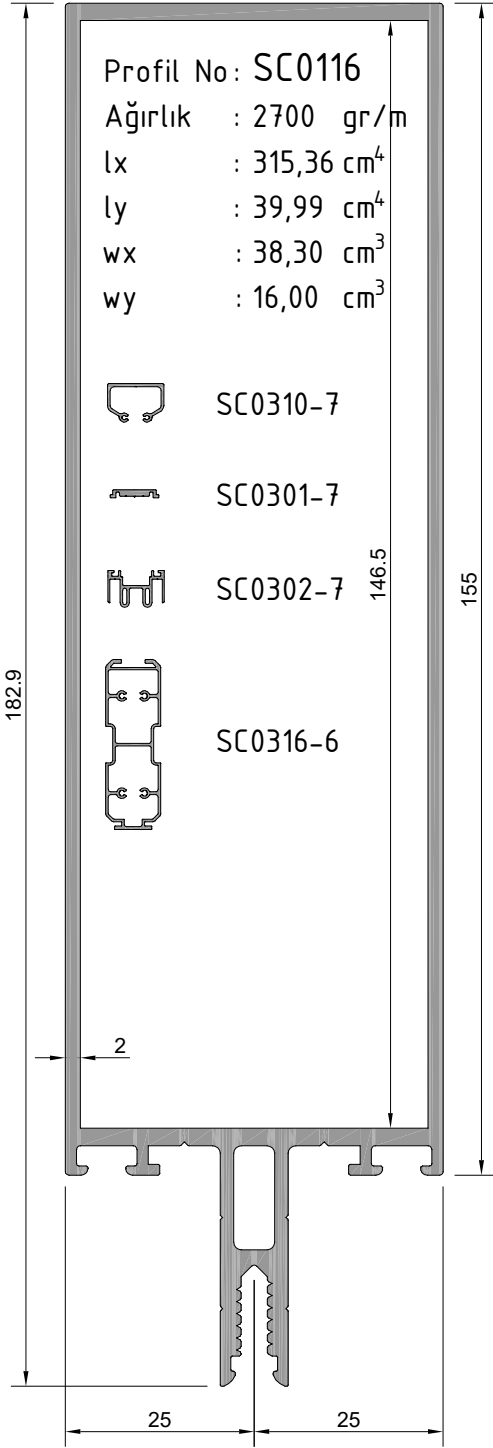

F50 KLASİK SİSTEM SİLİKON CEPHE PROFİLLERİ

F50 CONDENSAT SYSTEM
SILICONE FACADE PROFILE

ÜRÜN TEKNİK ÖZELLİKLERİ
PRODUCT'S TECHNICAL FEATURES

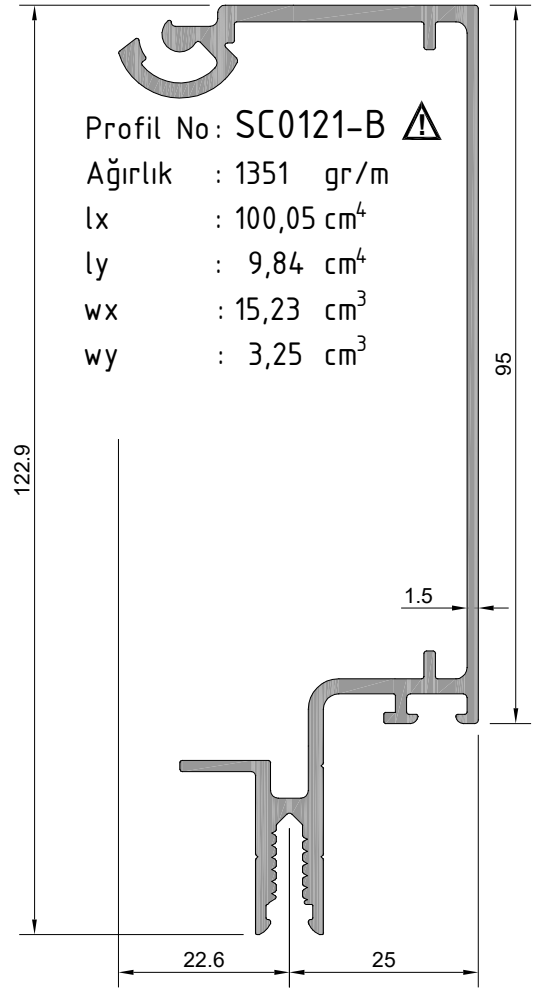
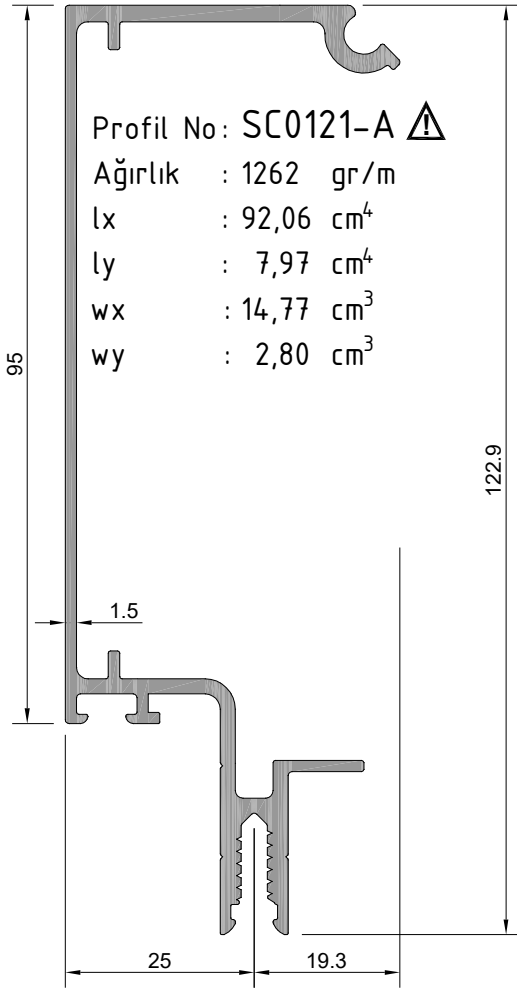

⚠ İşaretili profil için satış ekibinden bilgi alınız.

⚠ İşaretili profil için satış ekibinden bilgi alınız.

F50 KLASİK SİSTEM SİLİKON CEPHE PROFİLLERİ

F50 CONDENSAT SYSTEM
SILICONE FACADE PROFILE

ÜRÜN TEKNİK ÖZELLİKLERİ
PRODUCT'S TECHNICAL FEATURES

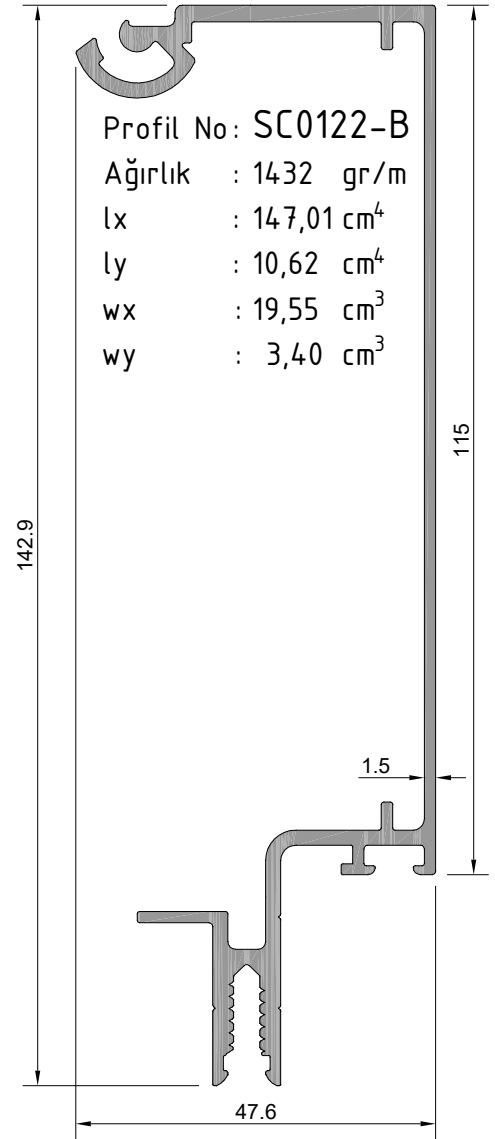
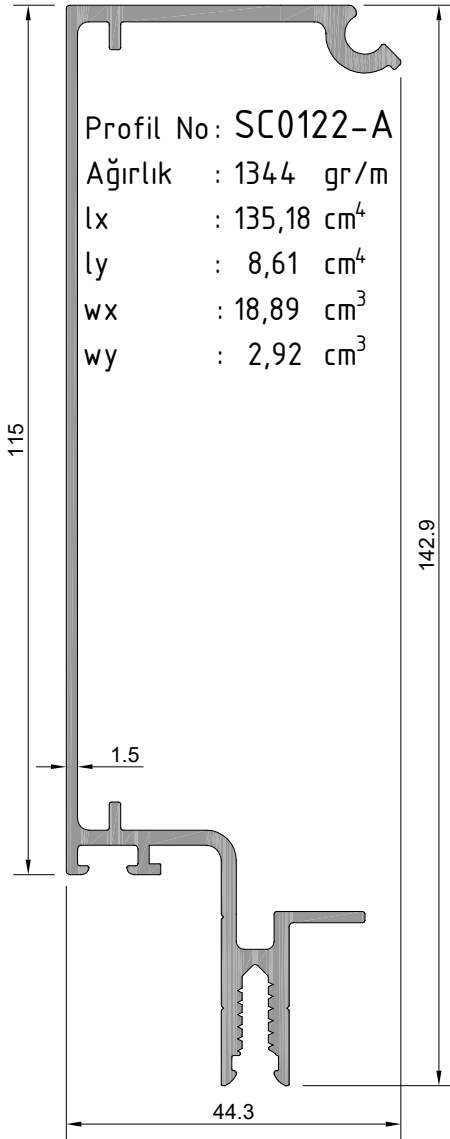

F50 KLASİK SİSTEM SİLİKON CEPHE PROFİLLERİ

F50 CONDENSAT SYSTEM
SILICONE FACADE PROFILE

ÜRÜN TEKNİK ÖZELLİKLERİ
PRODUCT'S TECHNICAL FEATURES

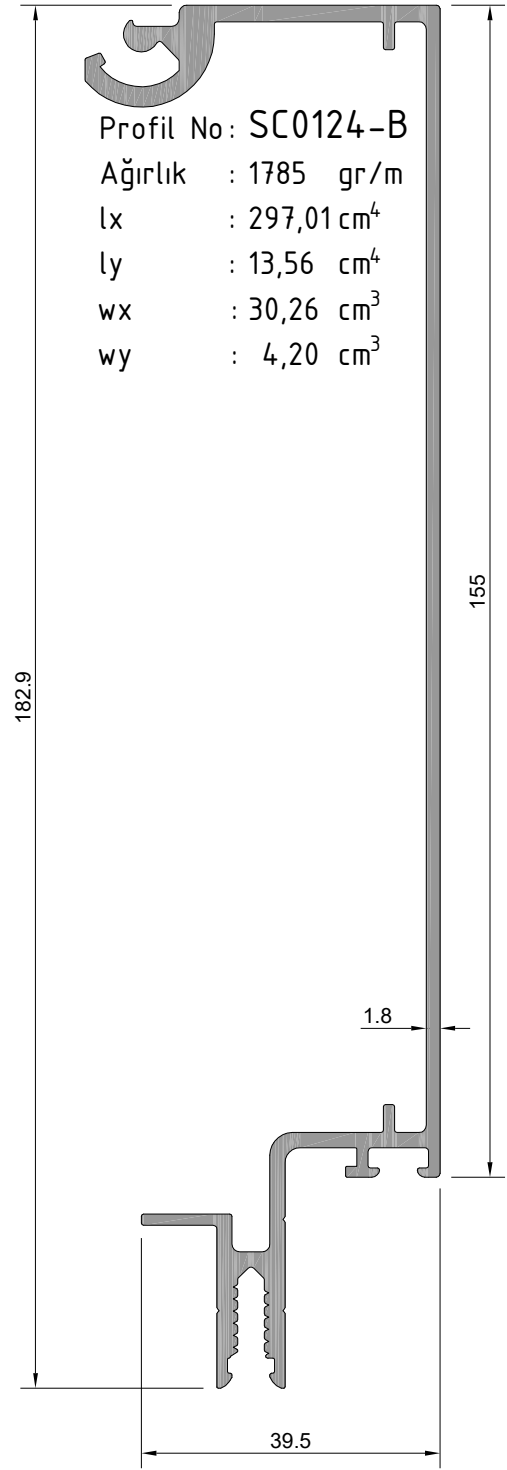
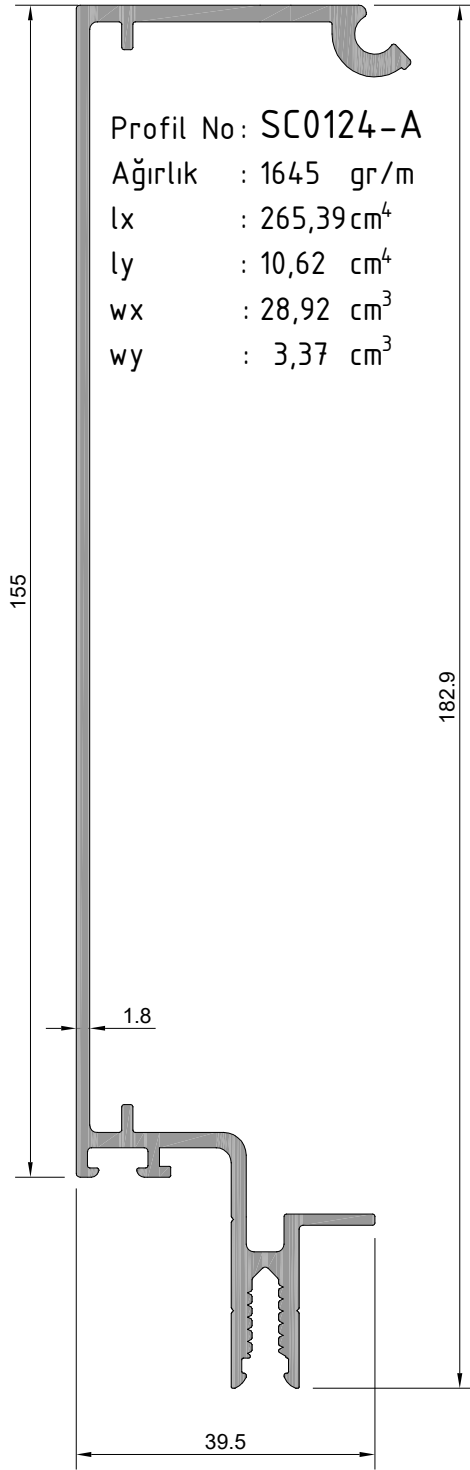

F50 KLASİK SİSTEM SİLİKON CEPHE PROFİLLERİ

F50 CONDENSAT SYSTEM
SILICONE FACADE PROFILE

ÜRÜN TEKNİK ÖZELLİKLERİ
PRODUCT'S TECHNICAL FEATURES

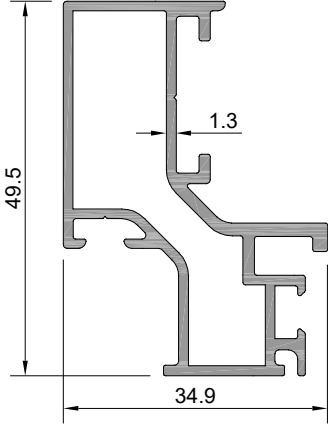

Profil No: SC0201
Ağırlık : 734 gr/m



SC0308-a



SC0304-a



SC0307-a

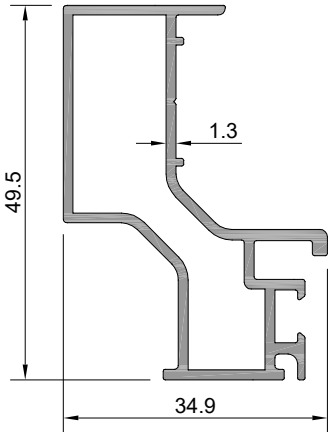

Profil No: SC0202
Ağırlık : 636 gr/m



SC0308-a



SC0304-a



SC0307-a

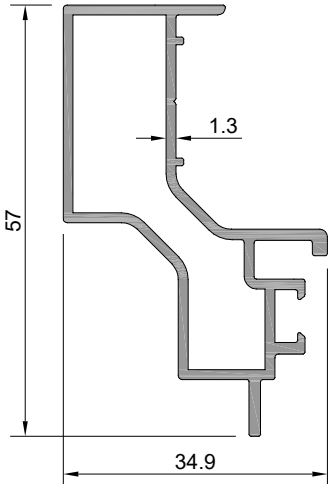

Profil No: SC0203
Ağırlık : 643 gr/m



SC0308-a



SC0304-a



SC0307-a

F50 KLASİK SİSTEM SİLİKON CEPHE PROFİLLERİ

F50 CONDENSAT SYSTEM
SILICONE FACADE PROFILE

ÜRÜN TEKNİK ÖZELLİKLERİ
PRODUCT'S TECHNICAL FEATURES

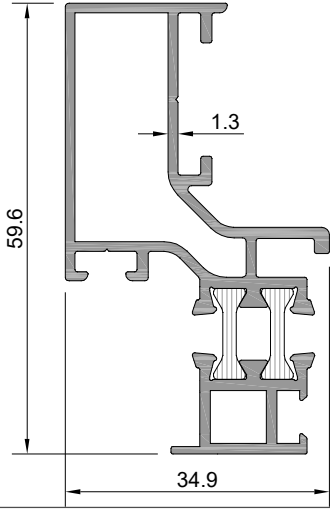

Profil No: SC0204

Ağırlık PVC : 970 gr/m

Ağırlık POLY: 963 gr/m



SC0308-b



SC0304-a



SC0309-a

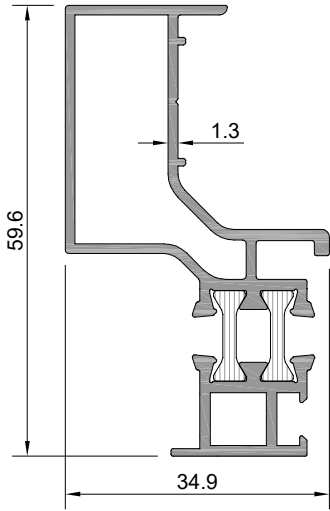

Profil No: SC0205

Ağırlık PVC : 894 gr/m

Ağırlık POLY: 886 gr/m



SC0308-b



SC0304-a



SC0309-a

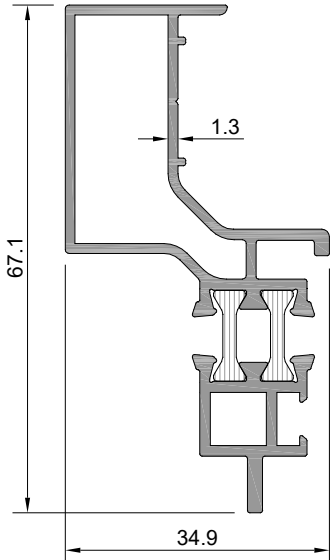

Profil No: SC0206

Ağırlık PVC : 924 gr/m

Ağırlık POLY: 917 gr/m



SC0308-b



SC0304-a



SC0309-a

F50 KLASİK SİSTEM SİLİKON CEPHE PROFİLLERİ

F50 CONDENSAT SYSTEM
SILICONE FACADE PROFILE

ÜRÜN TEKNİK ÖZELLİKLERİ
PRODUCT'S TECHNICAL FEATURES

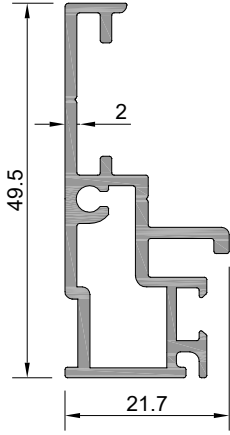

Profil No: SC0209
Ağırlık : 593 gr/m

 SC0304-a

 SC0307-a

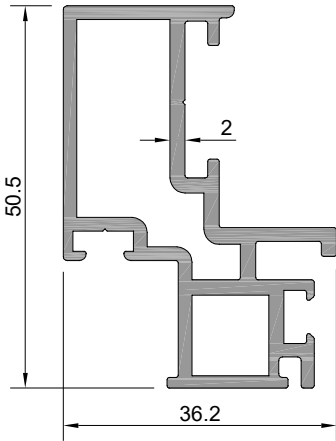

Profil No: SC0210
Ağırlık : 1001 gr/m

 SC0308-a

 SC0304-a

 SC0307-a

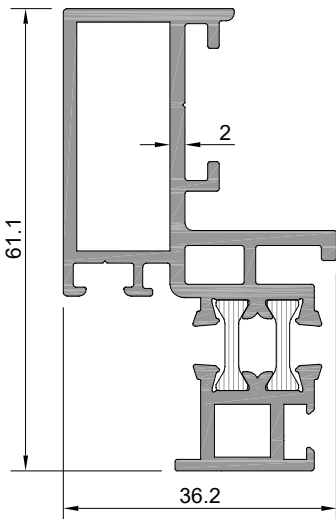

Profil No: SC0214

Ağırlık PVC : 1275 gr/m

Ağırlık POLY: 1268 gr/m

 SC0308-b

 SC0304-a

 SC0309-a

F50 KLASİK SİSTEM SİLİKON CEPHE PROFİLLERİ

F50 CONDENSAT SYSTEM
SILICONE FACADE PROFILE

ÜRÜN TEKNİK ÖZELLİKLERİ
PRODUCT'S TECHNICAL FEATURES

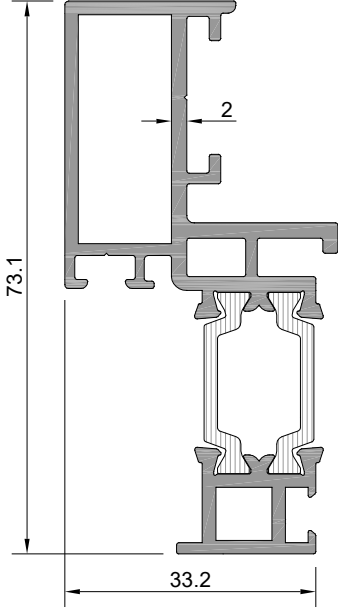

Profil No: SC0215

Ağırlık PVC : 1365 gr/m

Ağırlık POLY: 1350 gr/m

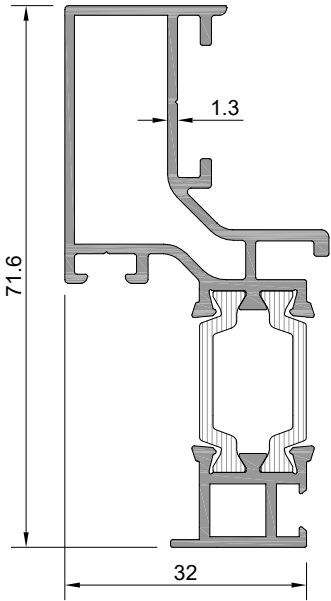

Profil No: SC0216

Ağırlık PVC : 1060 gr/m

Ağırlık POLY: 1045 gr/m

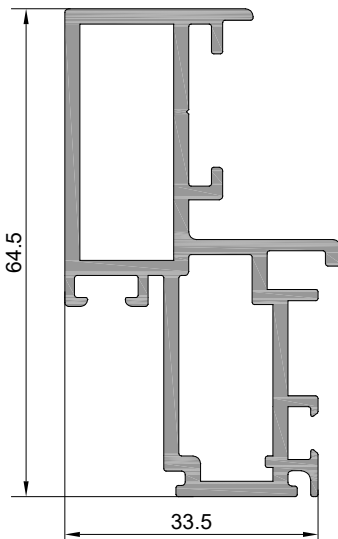

Profil No: SC0218

Ağırlık : 1241 gr/m



F50 KLASİK SİSTEM SİLİKON CEPHE PROFİLLERİ

F50 CONDENSAT SYSTEM
SILICONE FACADE PROFILE

PANEL CAM KOMBİNASYONU
GLASS PANEL COMBINATION

SC0201

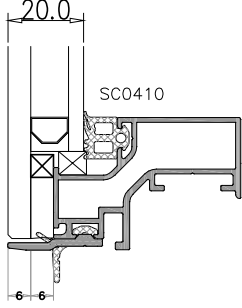

SC0210

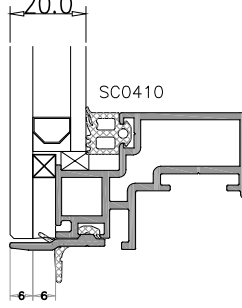

SC0204

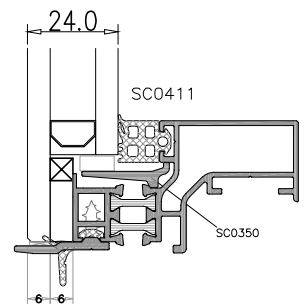
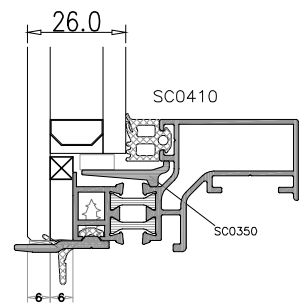
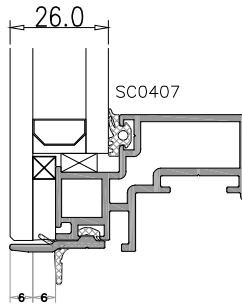
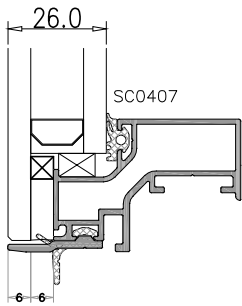
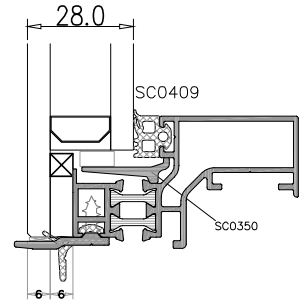
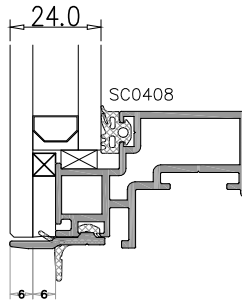
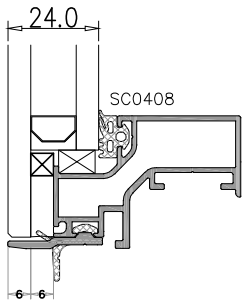
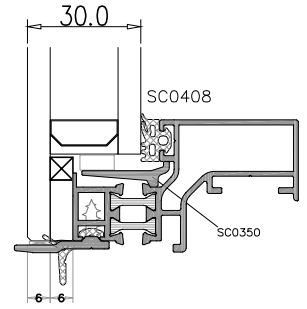
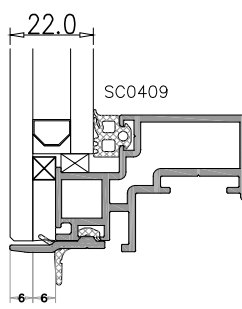
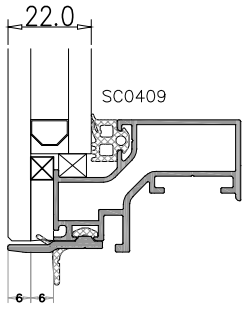
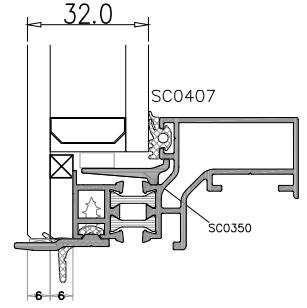

F50 KLASİK SİSTEM SİLİKON CEPHE PROFİLLERİ

F50 CONDENSAT SYSTEM
SILICONE FACADE PROFILE

PANEL CAM KOMBİNASYONU
GLASS PANEL COMBINATION

SC0214

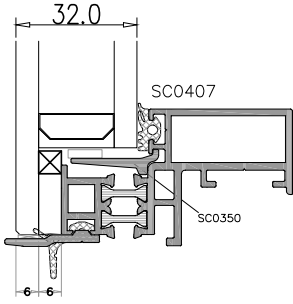

SC0215

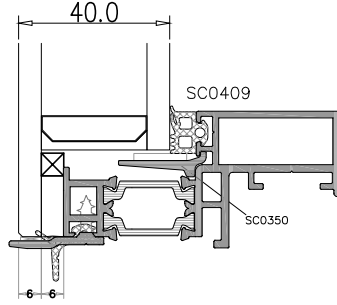

SC0216

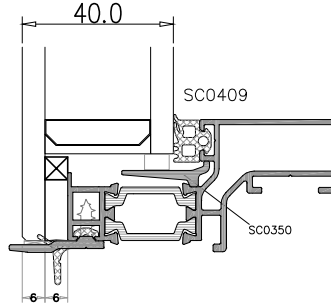

SC0218

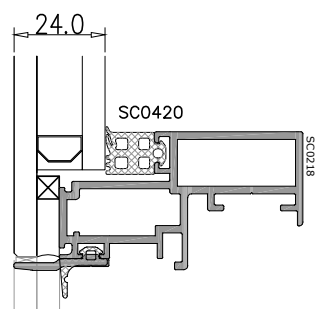
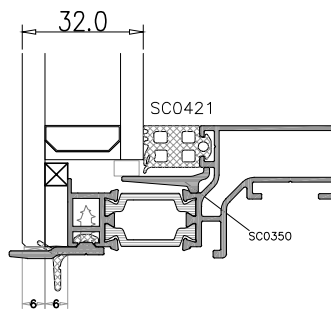
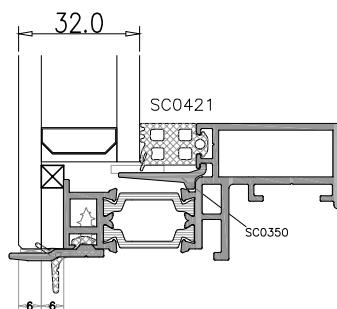
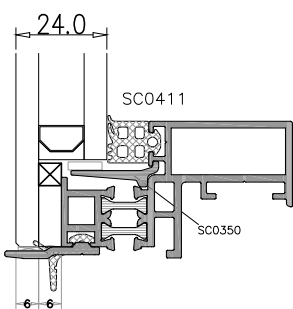
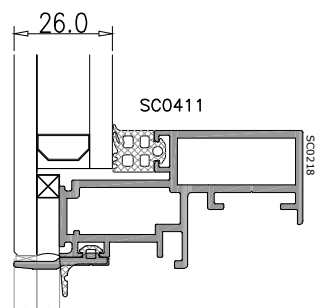
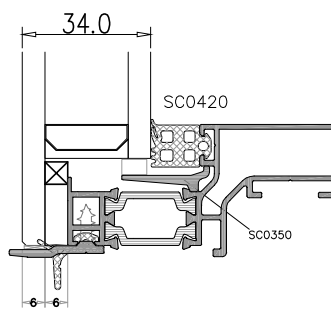
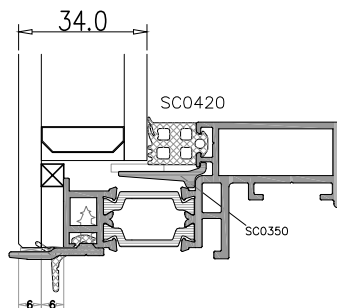
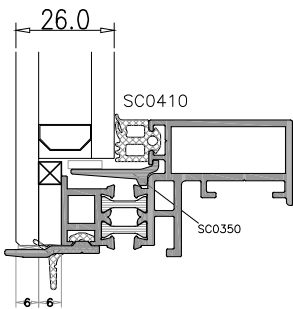
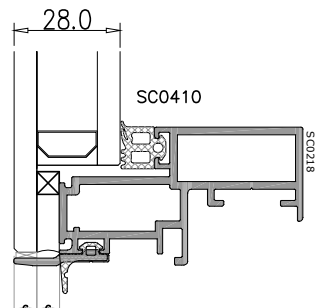
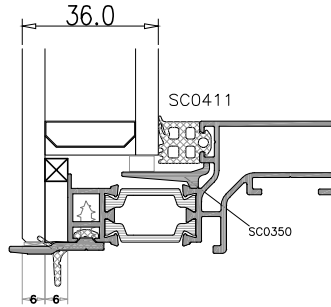
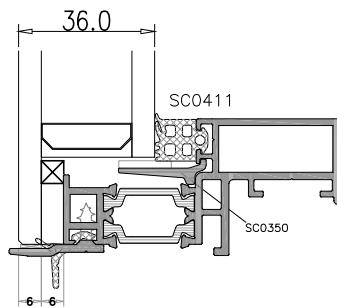
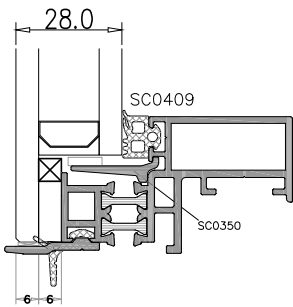
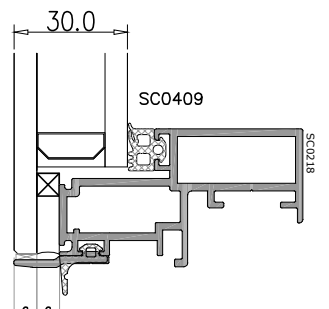
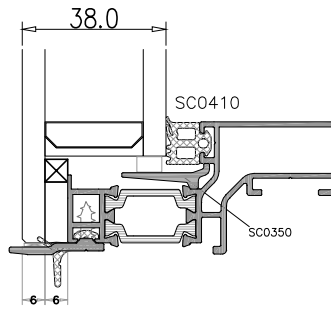
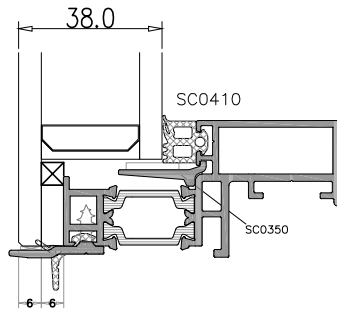
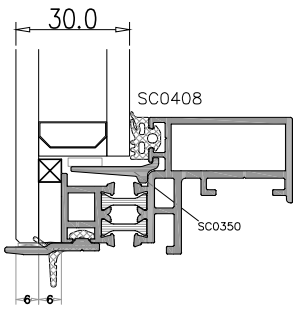
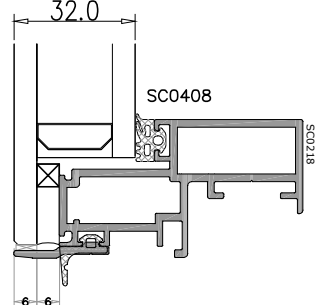

Profil değerleri teoriktir. Ağırlık olarak testimde yapılan tartım geçerlidir.
Profil imalatları TS EN 12020-2 ve TS EN 755-9 toleransı,
Moment değerleri EN 14024'e göre hesaplanmıştır.

Profile values are theoretical pre-shipment weight will be valid.
The tolerances of Profile manufacturing are calculated according to EN 12020-2
and TS EN 755-9; moment values are calculated according to EN 14024.

F50 KLASİK SİSTEM SİLİKON CEPHE PROFİLLERİ

F50 CONDENSAT SYSTEM
SILICONE FACADE PROFILE

KIRLANGIÇ GEÇME SİSTEMİ
T-CONNECTOR SYSTEM

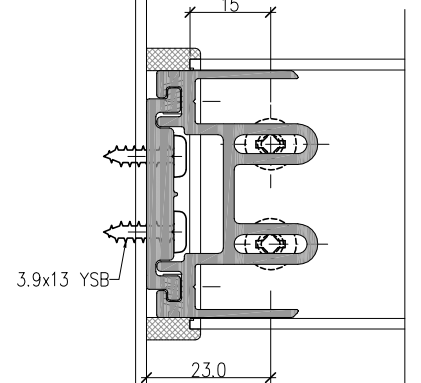
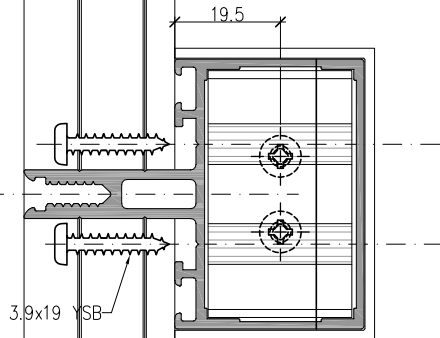
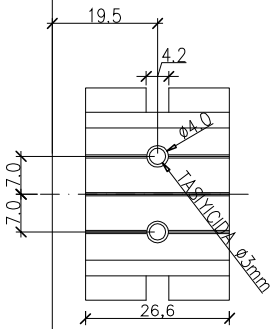
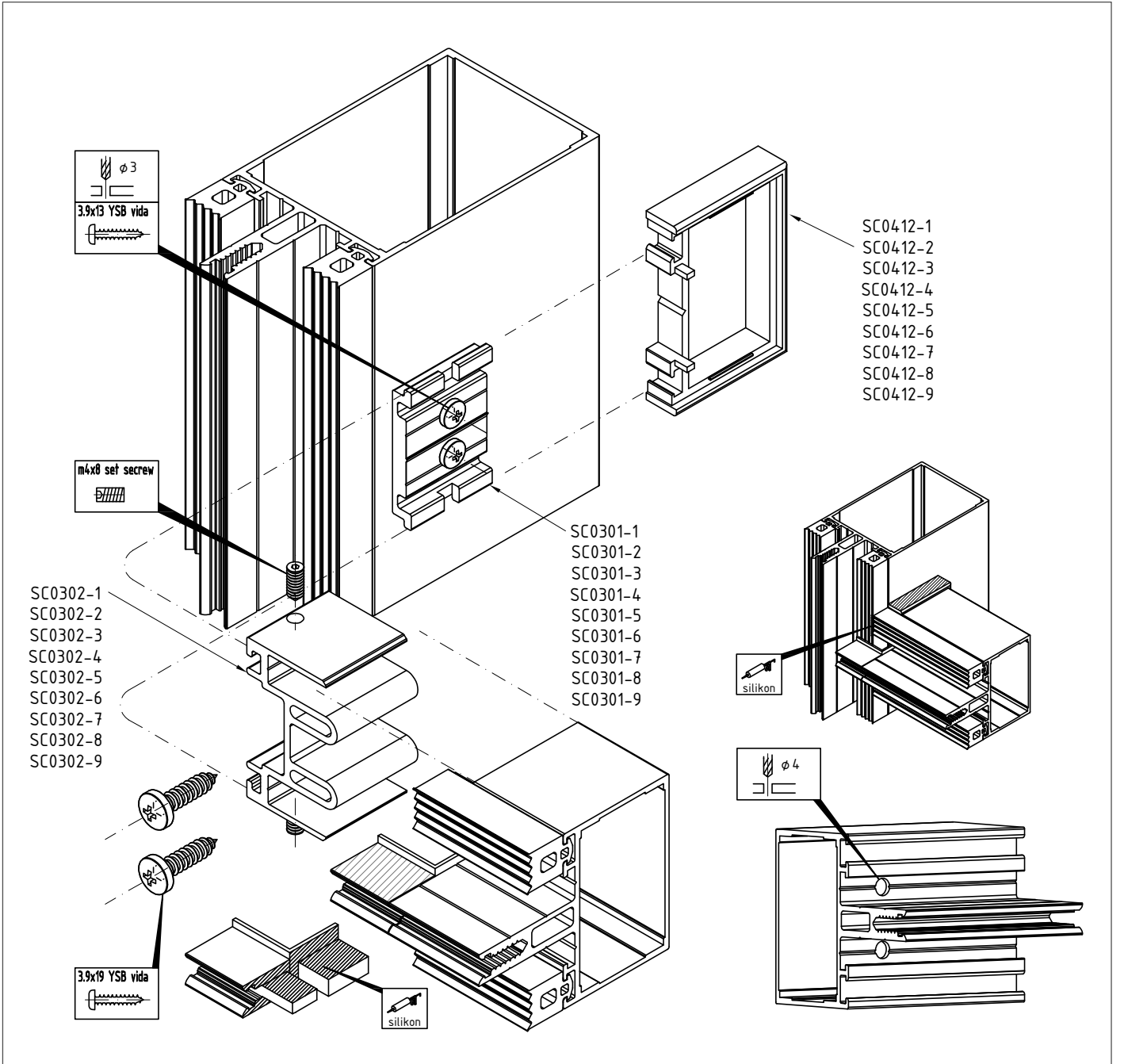

Profil değerleri teoriktir. Ağırlık olarak testimde yapılan tartım geçerlidir.
Profil imalatları TS EN 12020-2 ve TS EN 755-9 toleransı,
Moment değerleri EN 14024'e göre hesaplanmıştır.

Profile values are theoretical pre-shipment weight will be valid.
The tolerances of Profile manufacturing are calculated according to EN 12020-2
and TS EN 755-9; moment values are calculated according to EN 14024.

F50 KLASİK SİSTEM SİLİKON CEPHE PROFİLLERİ

F50 CONDENSAT SYSTEM
SILICONE FACADE PROFILE

KIRLANGIÇ GEÇME SİSTEMİ
T-CONNECTOR SYSTEM

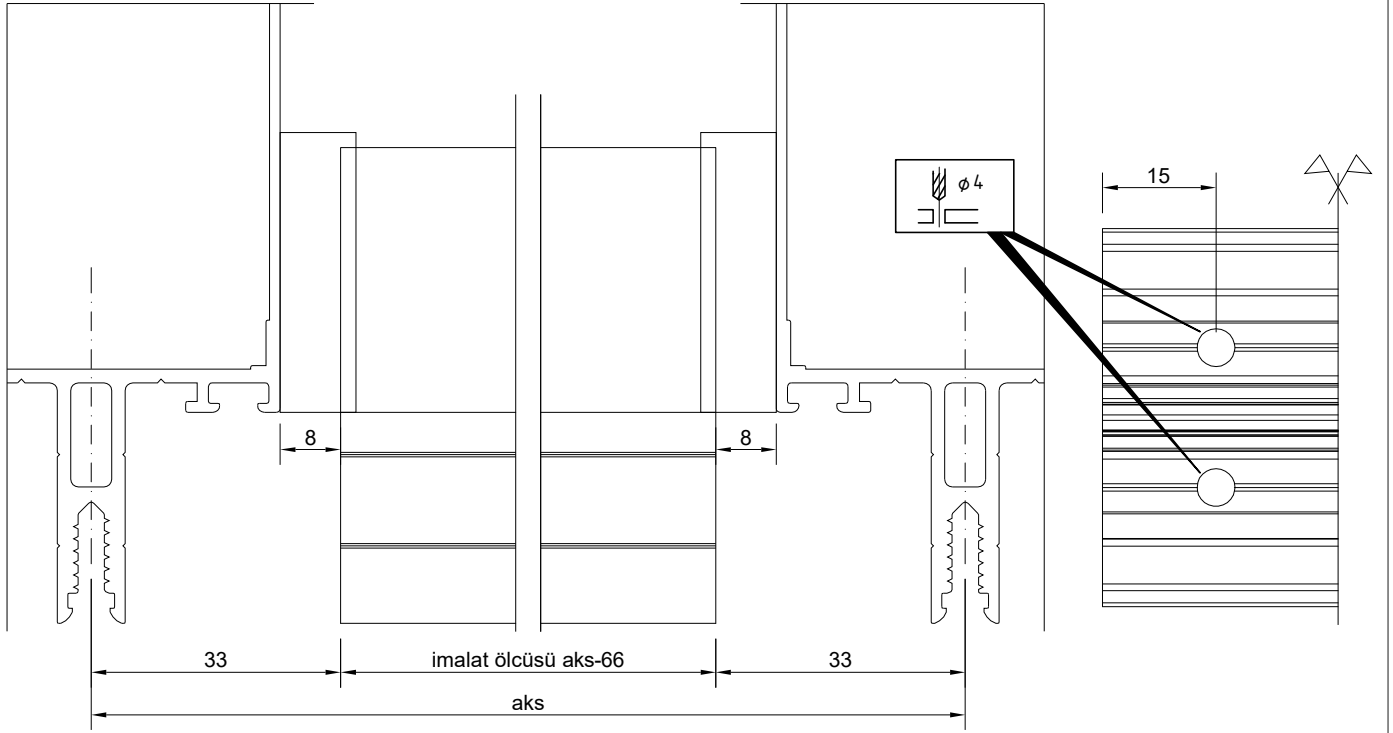

SC0301-1	SC0302-1	26.6mm	100 adet/pcs
SC0301-2	SC0302-2	46.4mm	100 adet/pcs
SC0301-3	SC0302-3	66.4mm	100 adet/pcs
SC0301-4	SC0302-4	86.4mm	100 adet/pcs
SC0301-5	SC0302-5	106mm	100 adet/pcs
SC0301-6	SC0302-6	126mm	100 adet/pcs
SC0301-7	SC0302-7	146mm	100 adet/pcs
SC0301-8	SC0302-8	166mm	100 adet/pcs
SC0301-9	SC0302-9	186mm	100 adet/pcs

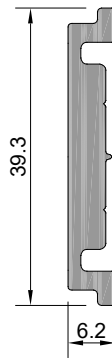

Profil No: SC0301
Ağırlık : 470 gr/m

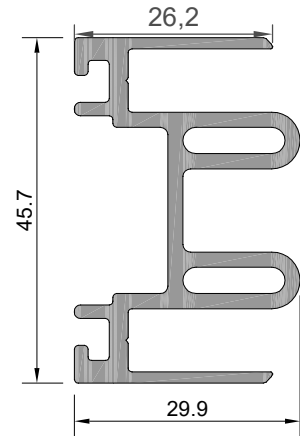

Profil No: SC0302
Ağırlık : 1002 gr/m

F50 KLASİK SİSTEM SİLİKON CEPHE PROFİLLERİ

F50 CONDENSAT SYSTEM
SILICONE FACADE PROFILE

KLASİK U BAĞL. SİSTEMİ - 1
T-CONNECTOR SYSTEM - 1

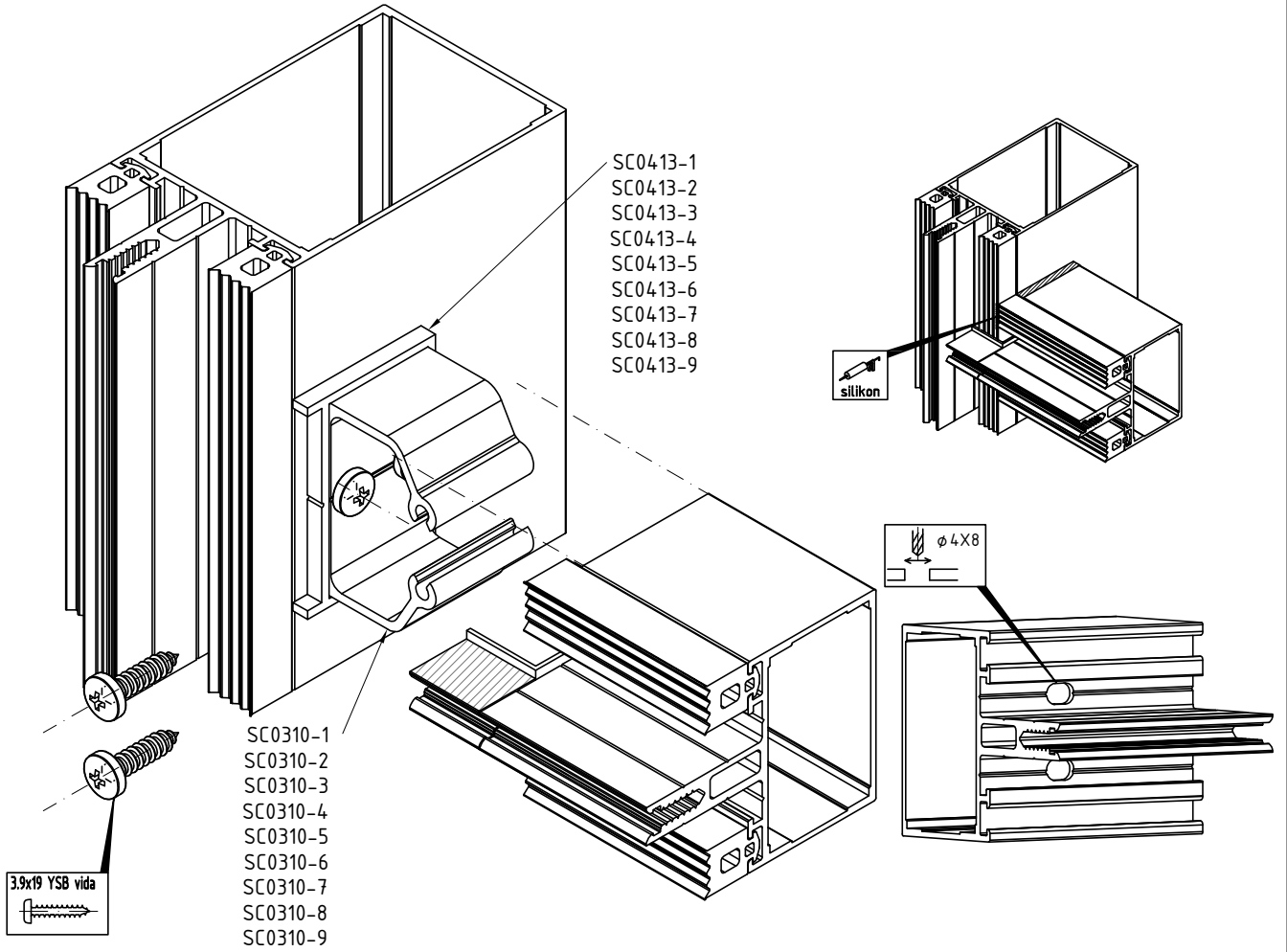

14.2

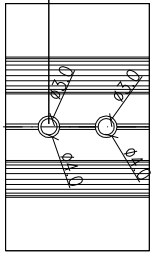

14.2

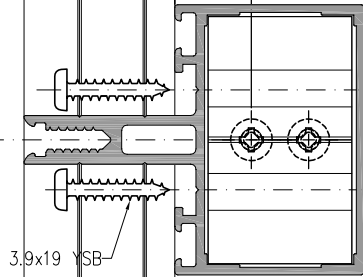

3.9x13 YSB

25

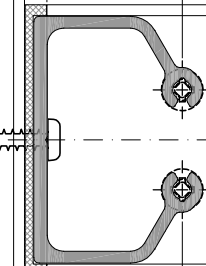

29

F50 KLASİK SİSTEM SİLİKON CEPHE PROFİLLERİ

F50 CONDENSAT SYSTEM
SILICONE FACADE PROFILE

KLASİK U BAĞL. SİSTEMİ - 1
T-CONNECTOR SYSTEM - 1

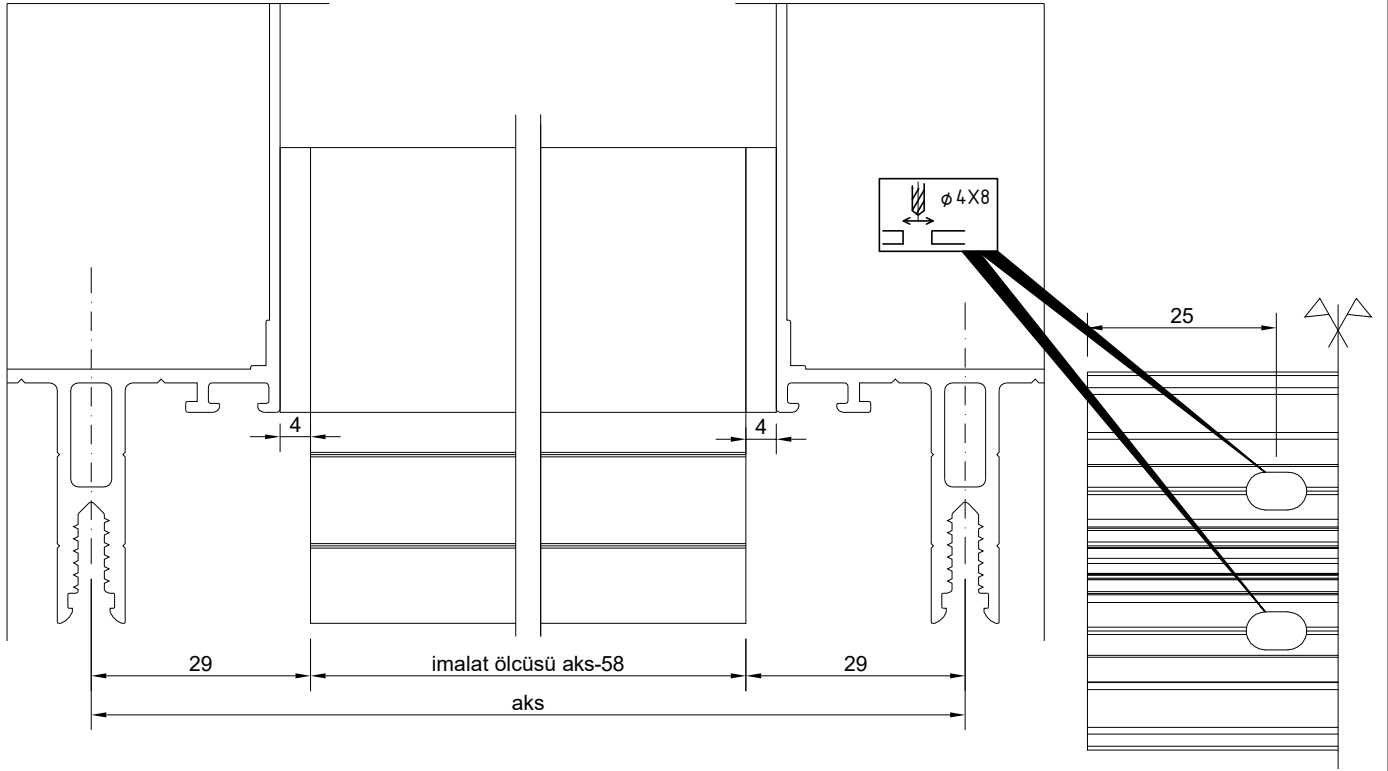

SC0310-1	26.6mm	100 adet/pcs
SC0310-2	46.4mm	100 adet/pcs
SC0310-3	66.4mm	100 adet/pcs
SC0310-4	86.4mm	100 adet/pcs
SC0310-5	106mm	100 adet/pcs
SC0310-6	126mm	100 adet/pcs
SC0310-7	146mm	100 adet/pcs
SC0310-8	166mm	100 adet/pcs
SC0310-9	186mm	100 adet/pcs

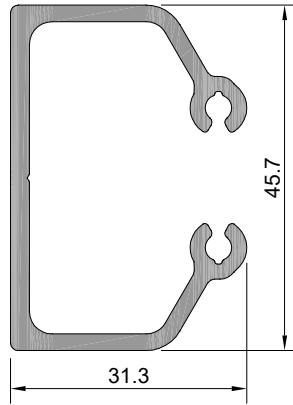

Profil No: SC0310

Ağırlık : 821 gr/m

F50 KLASİK SİSTEM SİLİKON CEPHE PROFİLLERİ

F50 CONDENSAT SYSTEM
SILICONE FACADE PROFILE

KLASİK U BAĞL. SİSTEMİ - 2
T-CONNECTOR SYSTEM - 2

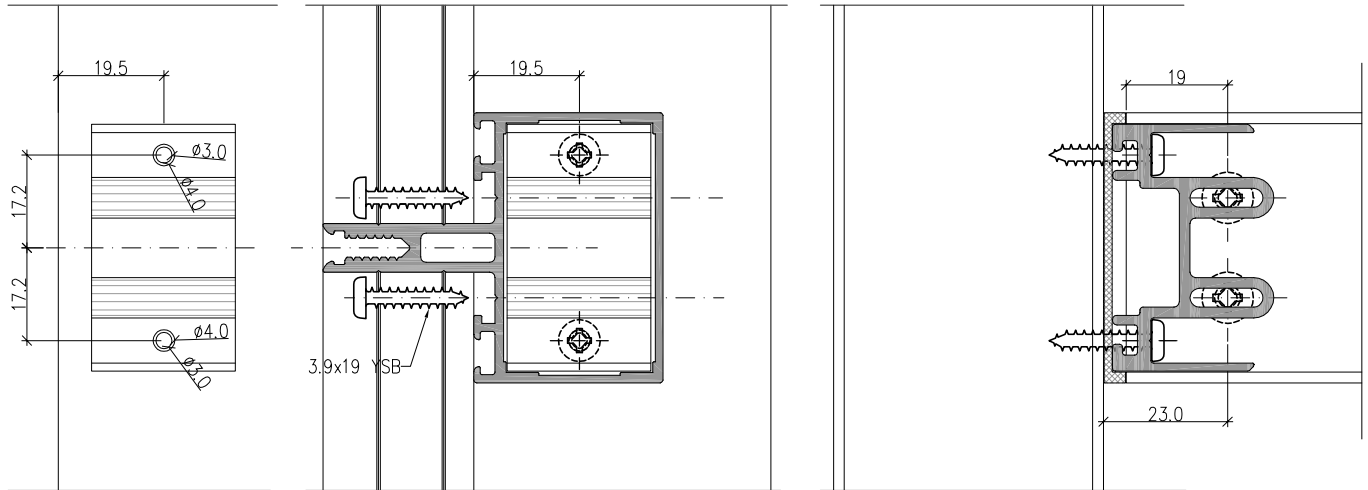
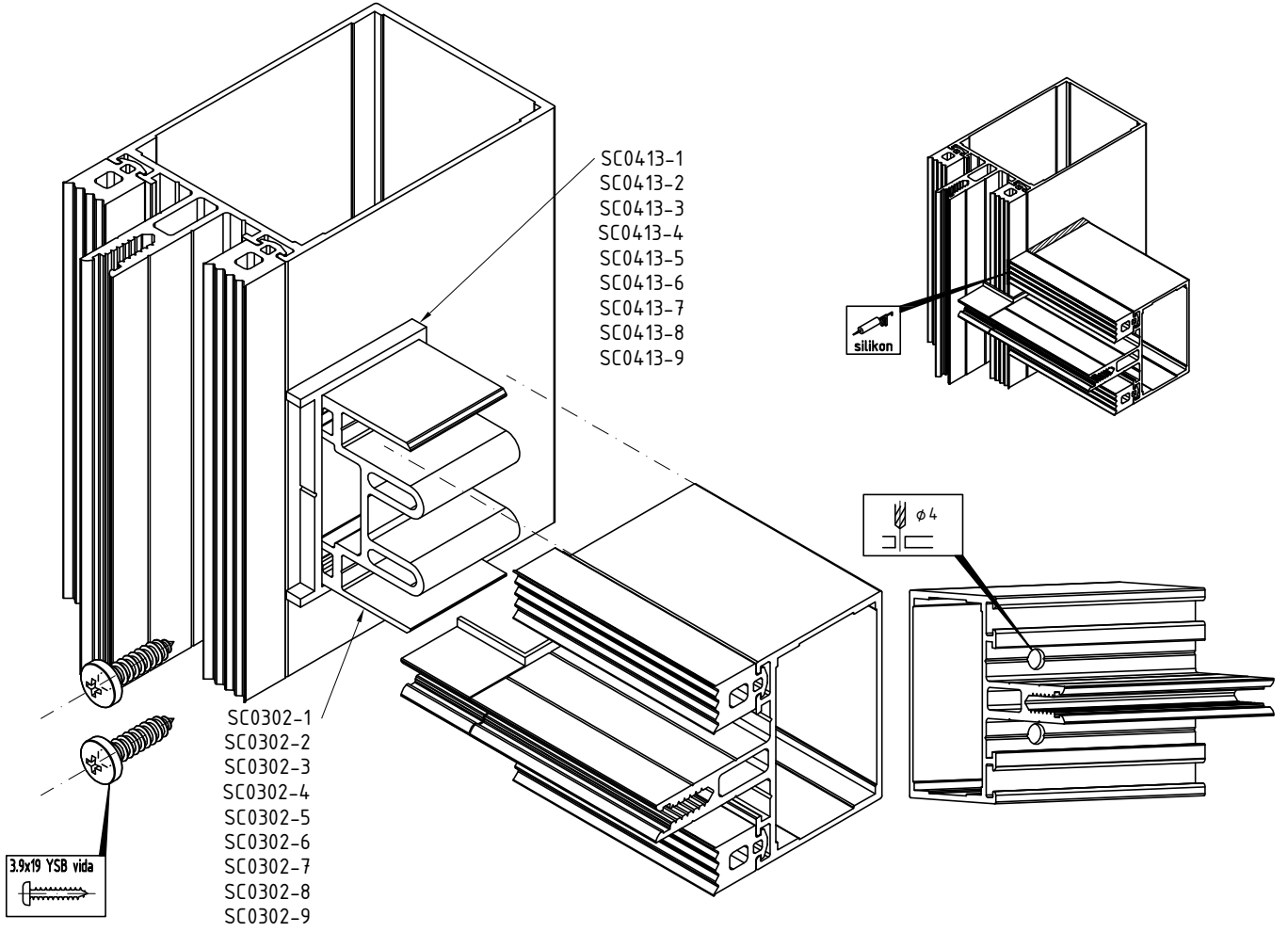

F50 KLASİK SİSTEM SİLİKON CEPHE PROFİLLERİ

F50 CONDENSAT SYSTEM
SILICONE FACADE PROFILE

KLASİK U BAĞL. SİSTEMİ - 2
T-CONNECTOR SYSTEM - 2

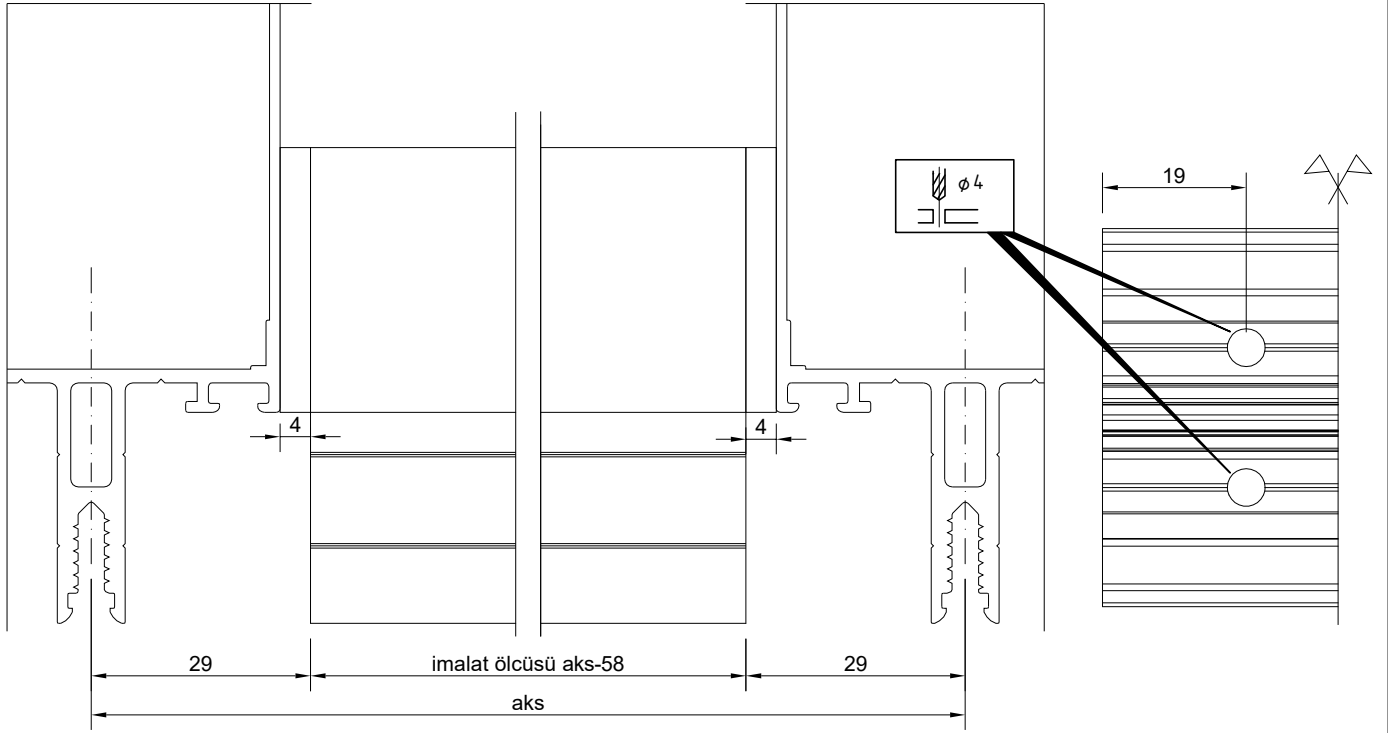

SC0302-1	26.6mm	100 adet/pcs
SC0302-2	46.4mm	100 adet/pcs
SC0302-3	66.4mm	100 adet/pcs
SC0302-4	86.4mm	100 adet/pcs
SC0302-5	106mm	100 adet/pcs
SC0302-6	126mm	100 adet/pcs
SC0302-7	146mm	100 adet/pcs
SC0302-8	166mm	100 adet/pcs
SC0302-9	186mm	100 adet/pcs

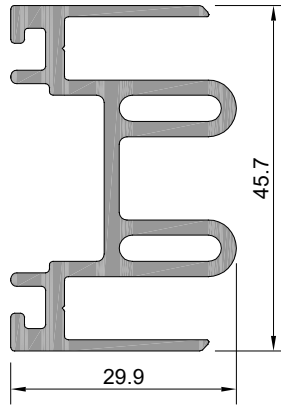

Profil No: SC0302

Ağırlık : 1002 gr/m

F50 KLASİK SİSTEM SİLİKON CEPHE PROFİLLERİ

F50 CONDENSAT SYSTEM
SILICONE FACADE PROFILE

KÖŞE PRES PR.
PRES CORNER PROFILE

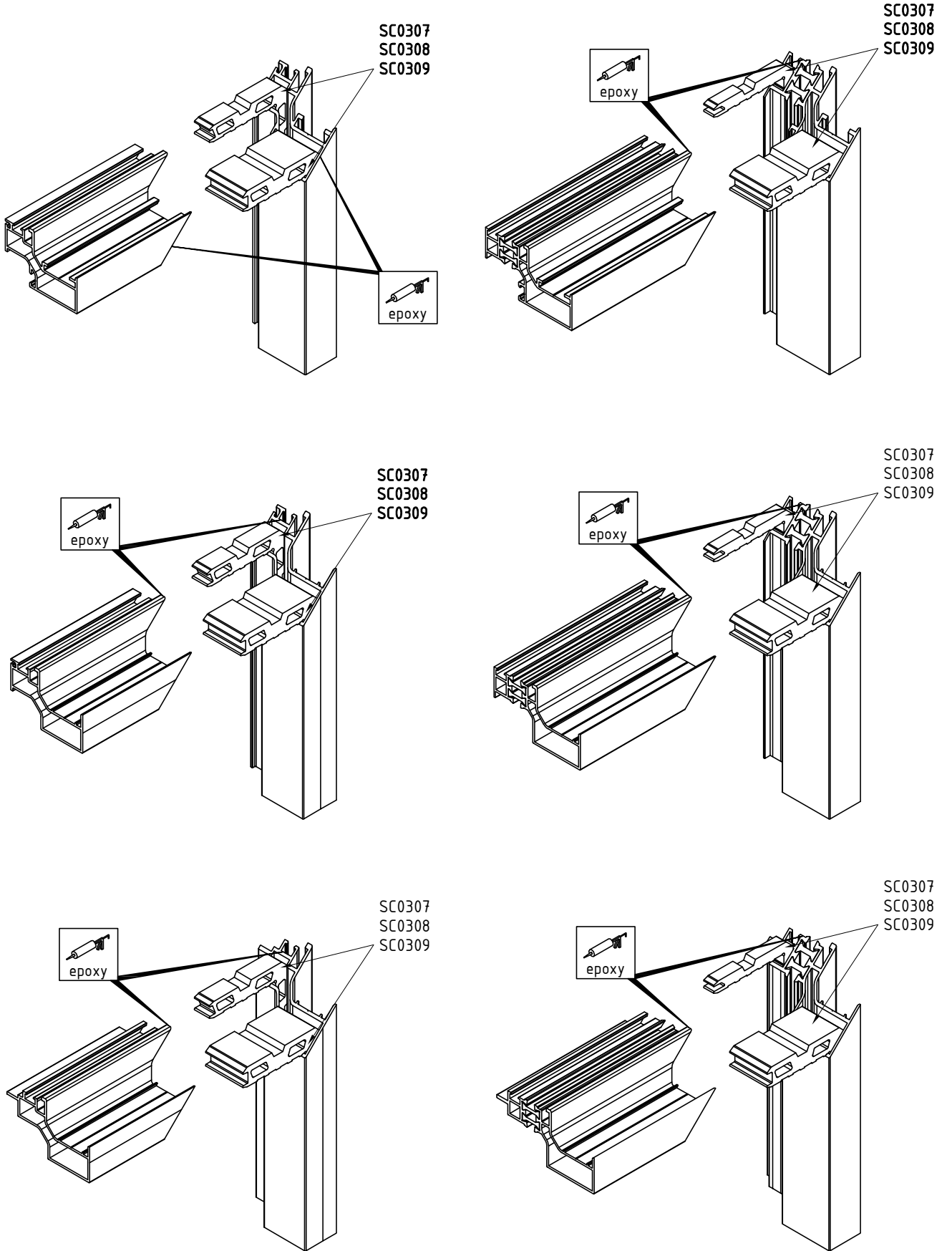

F50 KLASİK SİSTEM SİLİKON CEPHE PROFİLLERİ

F50 CONDENSAT SYSTEM
SILICONE FACADE PROFILE

ÜRÜN TEKNİK ÖZELLİKLERİ
PRODUCT'S TECHNICAL FEATURES

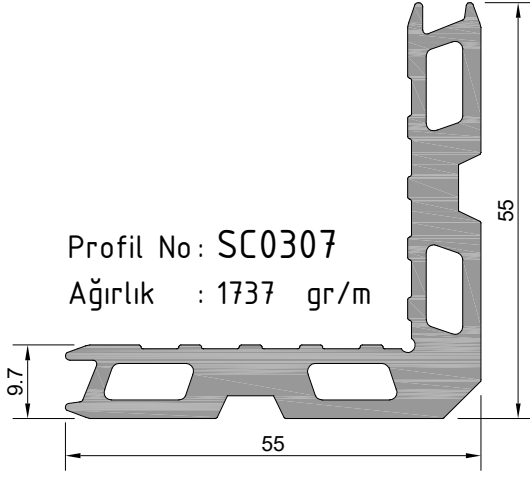

SC0307-a	10.25mm	100 adet/pcs	SC0307-f	25.6mm	100 adet/pcs
SC0307-b	27mm	100 adet/pcs	SC0307-g	6mm	100 adet/pcs
SC0307-c	8.5mm	100 adet/pcs	SC0307-h	4.7mm	100 adet/pcs
SC0307-d	23.9mm	100 adet/pcs	SC0307-i	26.28mm	100 adet/pcs
SC0307-e	6.3mm	100 adet/pcs	SC0307-j	29.5mm	100 adet/pcs

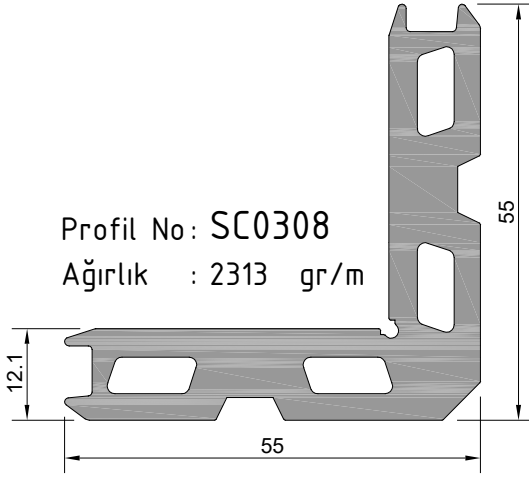

SC0308-a	25.68mm	100 adet/pcs
SC0308-b	29.74mm	100 adet/pcs
SC0308-c	24.36mm	100 adet/pcs
SC0308-d	10.30mm	100 adet/pcs
SC0308-e	6.70mm	100 adet/pcs
SC0308-f	23mm	100 adet/pcs
SC0308-g	19.50mm	100 adet/pcs

SC0308-h	9.9mm	100 adet/pcs
----------	-------	--------------

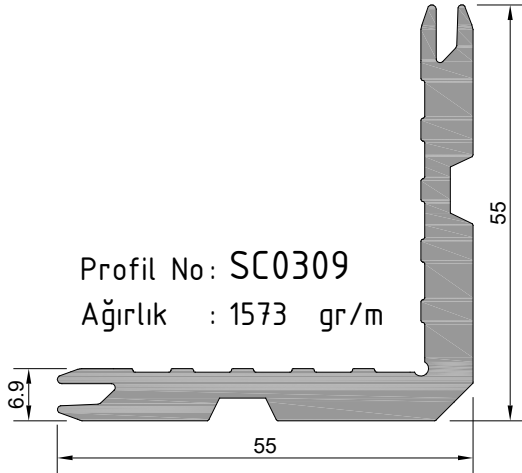

SC0309-a	6.5mm	100 adet/pcs	SC0309-f	4.7mm	100 adet/pcs
SC0309-b	8.5mm	100 adet/pcs	SC0309-g	54.2mm	100 adet/pcs
SC0309-c	18.9mm	100 adet/pcs	SC0309-h	23.8mm	100 adet/pcs
SC0309-d	20mm	100 adet/pcs	SC0309-i	48.2mm	100 adet/pcs
SC0309-e	25.3mm	100 adet/pcs	SC0309-j	52.8mm	100 adet/pcs

F50 KLASİK SİSTEM SİLİKON CEPHE PROFİLLERİ

F50 CONDENSAT SYSTEM
SILICONE FACADE PROFILE

ÜRÜN TEKNİK ÖZELLİKLERİ
PRODUCT'S TECHNICAL FEATURES

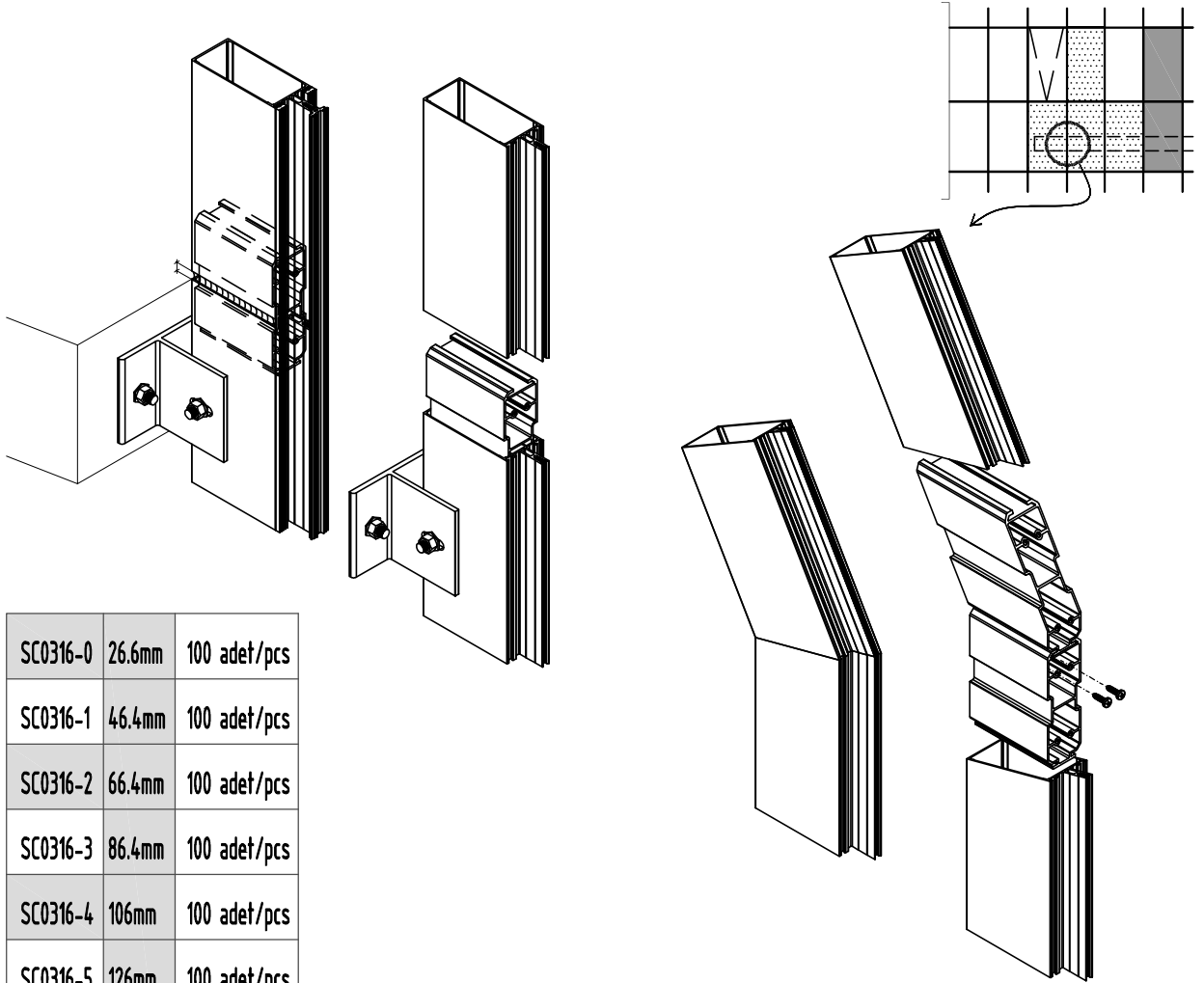

SC0316-0	26.6mm	100 adet/pcs
SC0316-1	46.4mm	100 adet/pcs
SC0316-2	66.4mm	100 adet/pcs
SC0316-3	86.4mm	100 adet/pcs
SC0316-4	106mm	100 adet/pcs
SC0316-5	126mm	100 adet/pcs
SC0316-6	146mm	100 adet/pcs
SC0316-7	166mm	100 adet/pcs
SC0316-8	186mm	100 adet/pcs

Profil No: SC0316

Ağırlık : 3079 gr/m

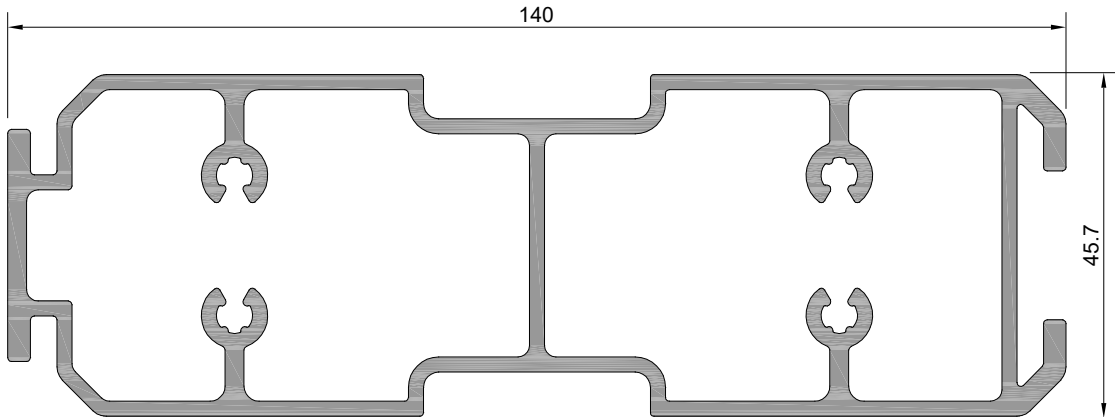

F50 KLASİK SİSTEM SİLİKON CEPHE PROFİLLERİ

F50 CONDENSAT SYSTEM
SILICONE FACADE PROFILE

ÜRÜN TEKNİK ÖZELLİKLERİ
PRODUCT'S TECHNICAL FEATURES

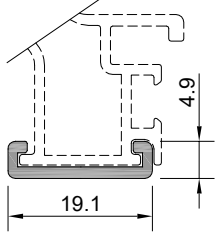

Profil No: SC0207
Ağırlık : 109 gr/m

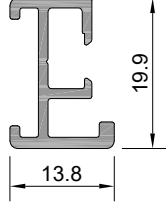

Profil No: SC0217
Ağırlık : 242 gr/m

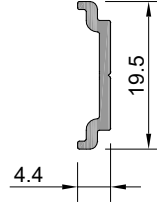

Profil No: SC0303
Ağırlık : 96 gr/m

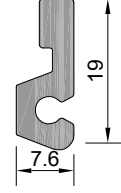

Profil No: SC0304
Ağırlık : 250 gr/m

SC0304-a	50 mm	100 adet/pcs
----------	-------	--------------

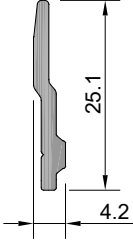

Profil No: SC0312
Ağırlık : 147 gr/m

SC0312-a	50 mm	100 adet/pcs
----------	-------	--------------

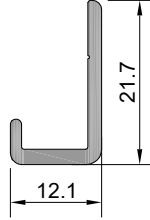

Profil No: SC0343
Ağırlık : 173 gr/m

SC0343-a	50 mm	100 adet/pcs
----------	-------	--------------

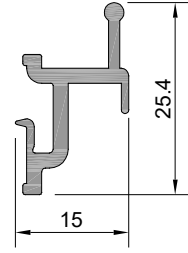

Profil No: SC0344
Ağırlık : 244 gr/m

SC0344-a	50 mm	100 adet/pcs
----------	-------	--------------

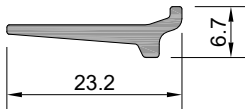

Profil No: SC0350
Ağırlık : 140 gr/m

SC0350-a	50 mm	100 adet/pcs
----------	-------	--------------

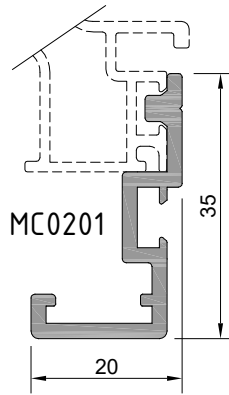

Profil No: MC0201
Ağırlık : 397 gr/m

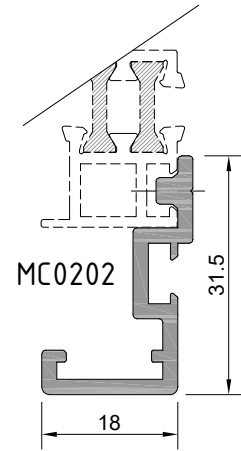

Profil No: MC0202
Ağırlık : 378 gr/m

F50 KLASİK SİSTEM SİLİKON CEPHE PROFİLLERİ

F50 CONDENSAT SYSTEM
SILICONE FACADE PROFILE

ÜRÜN TEKNİK ÖZELLİKLERİ
PRODUCT'S TECHNICAL FEATURES

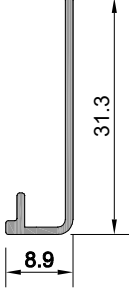

Profil No: SC0346

Ağırlık : 120 gr/m

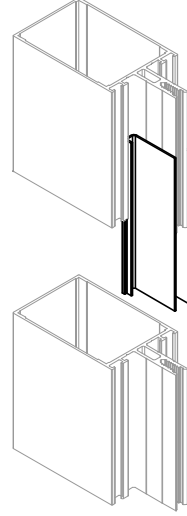
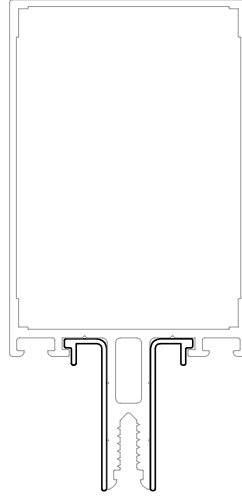
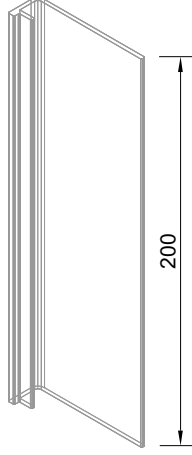

F50 KLASİK SİSTEM
SİLİKON CEPHE
F50 CLASSIC SYSTEM
SILICONE FACADE

YAN BİTİM - SABİT
WALL CONNECTION-FIXED

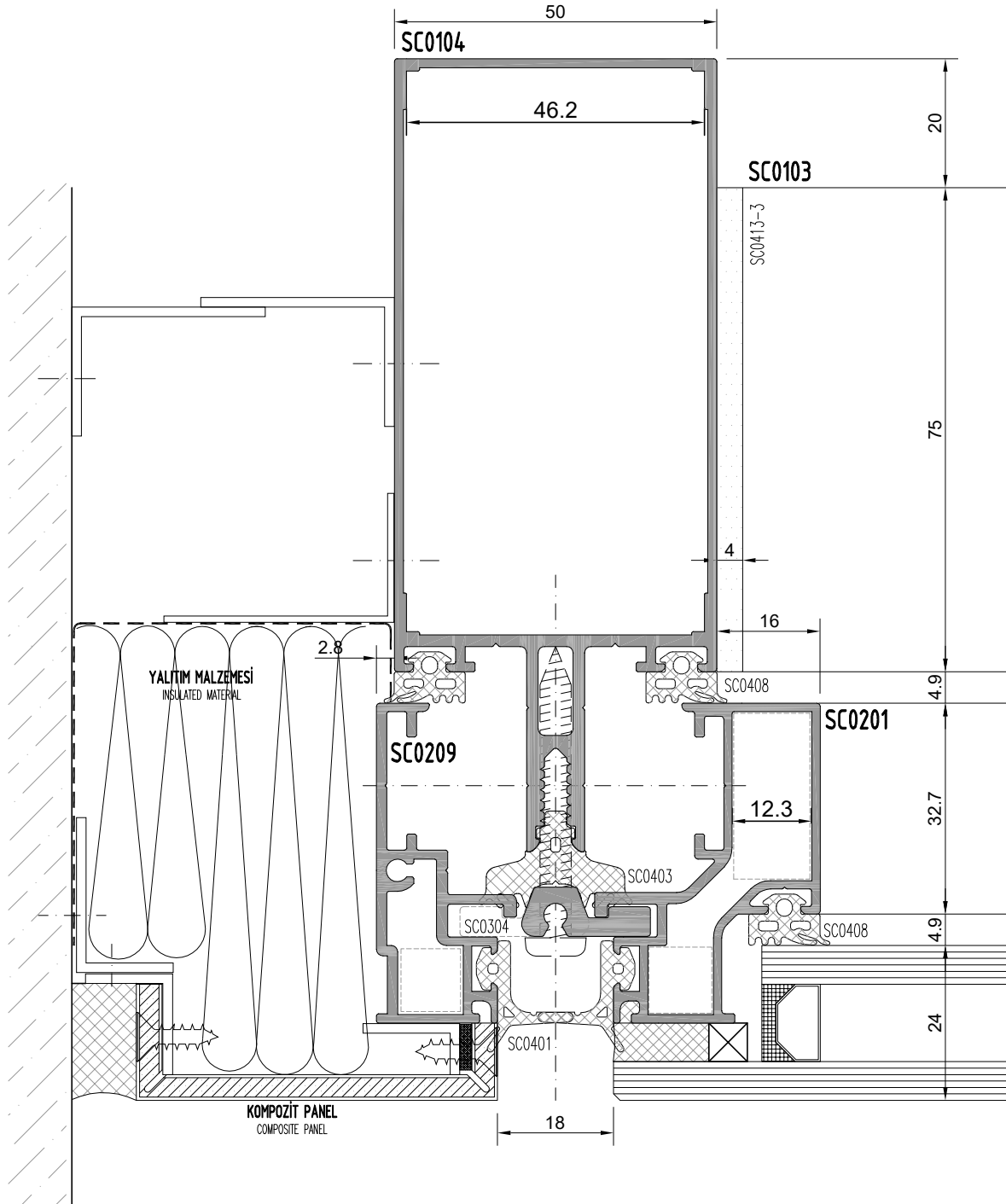
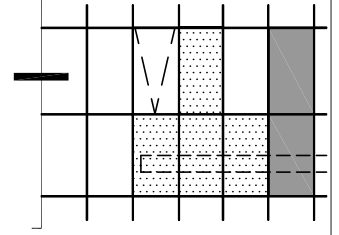

F50 KLASİK SİSTEM
SİLİKON CEPHE
F50 CLASSIC SYSTEM
SILICONE FACADE

SABİT - SABİT
FIXED-FIXED

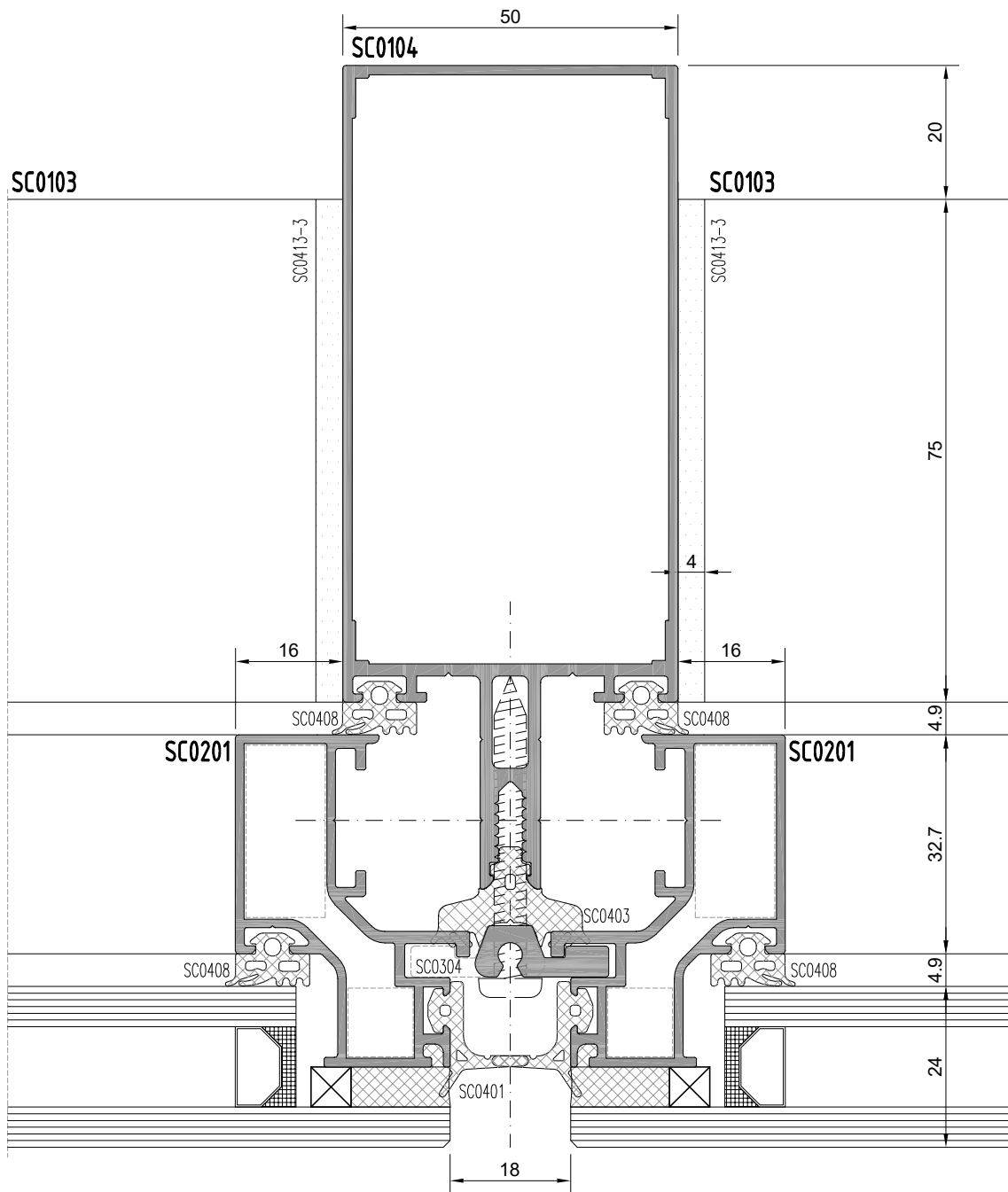
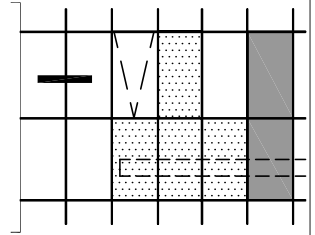

F50 KLASİK SİSTEM
SİLİKON CEPHE
F50 CLASSIC SYSTEM
SILICONE FACADE

SABIT - KANAT
FIXED-SASH

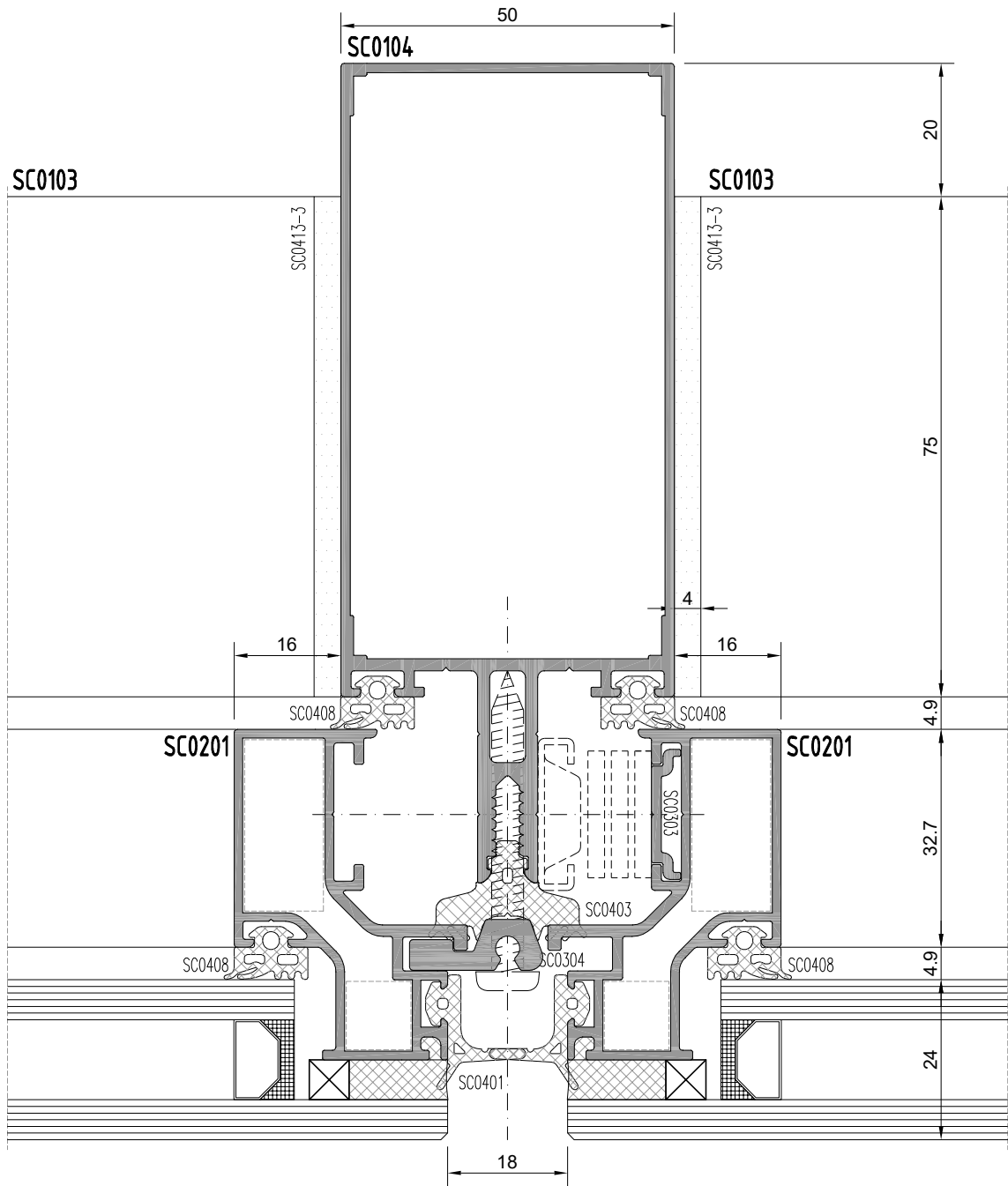
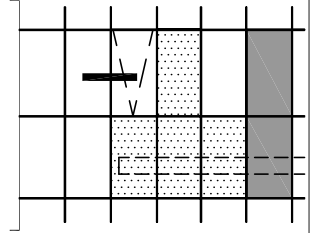

F50 KLASİK SİSTEM
SİLİKON CEPHE
F50 CLASSIC SYSTEM
SILICONE FACADE

KANAT - SPANDREL
SASH-SPANDREL

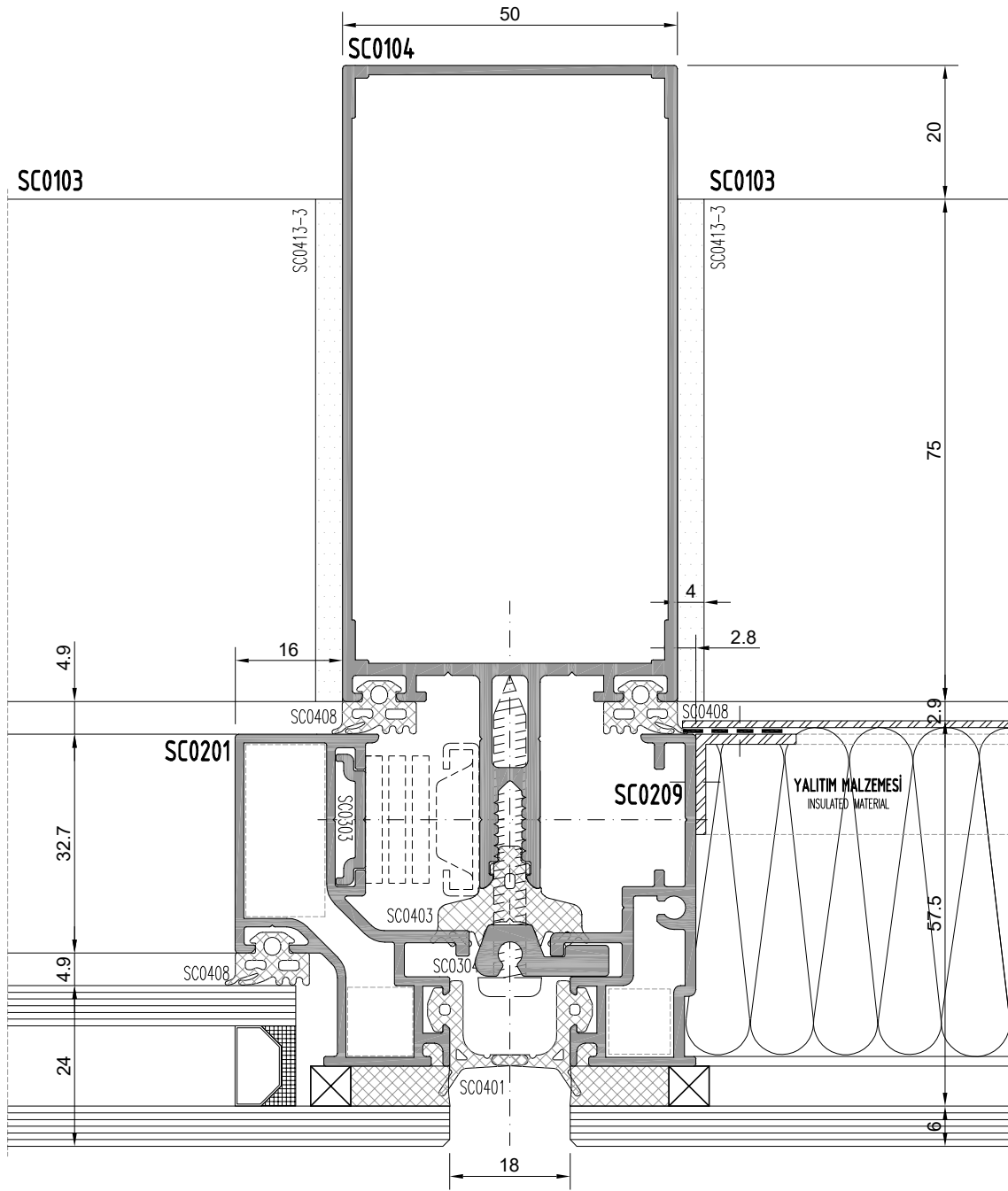
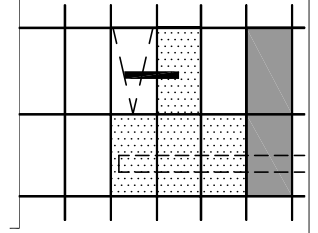

F50 KLASİK SİSTEM
SİLİKON CEPHE
F50 CLASSIC SYSTEM
SILICONE FACADE

SABIT - KANAT
FIXED-SASH

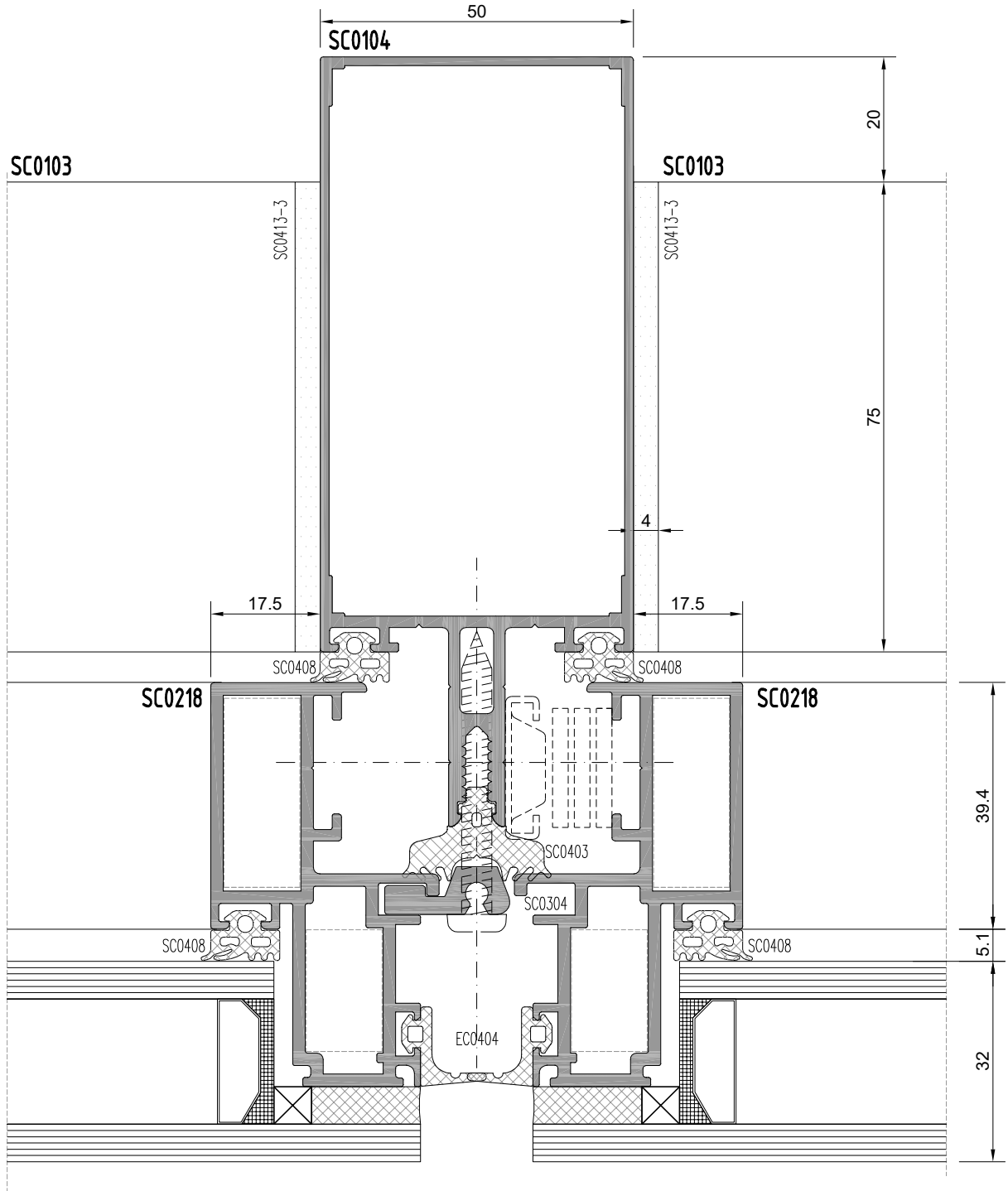
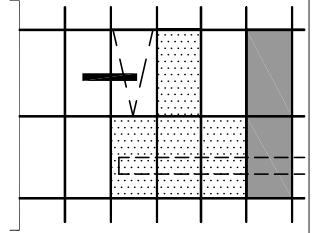

F50 KLASİK SİSTEM
SİLİKON CEPHE
F50 CLASSIC SYSTEM
SILICONE FACADE

SABİT - SABİT
FIXED-FIXED

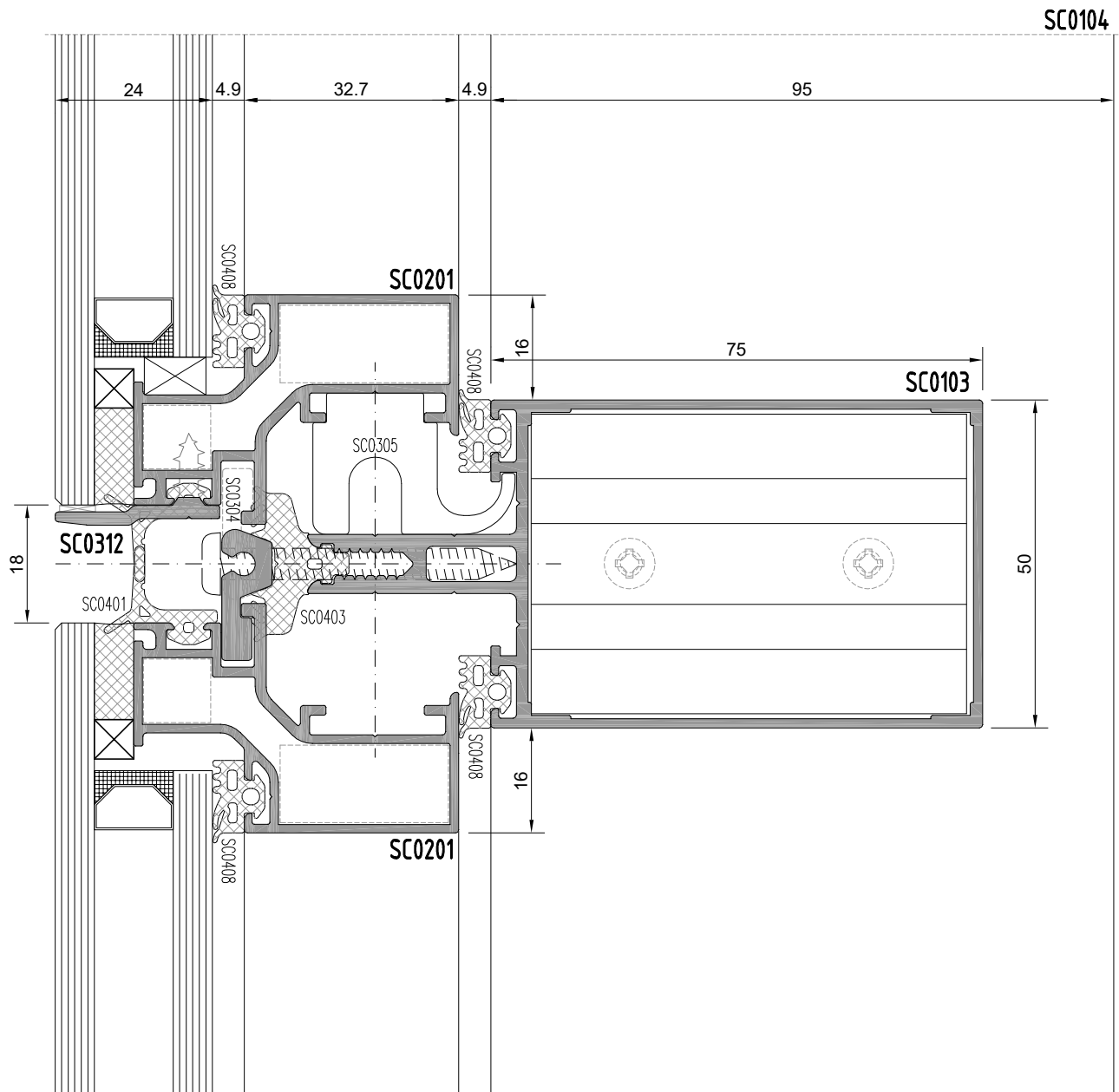
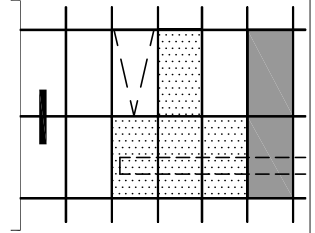

F50 KLASİK SİSTEM
SİLİKON CEPHE
F50 CLASSIC SYSTEM
SILICONE FACADE

SABİT - SPANDREL
FIXED-SPANDREL

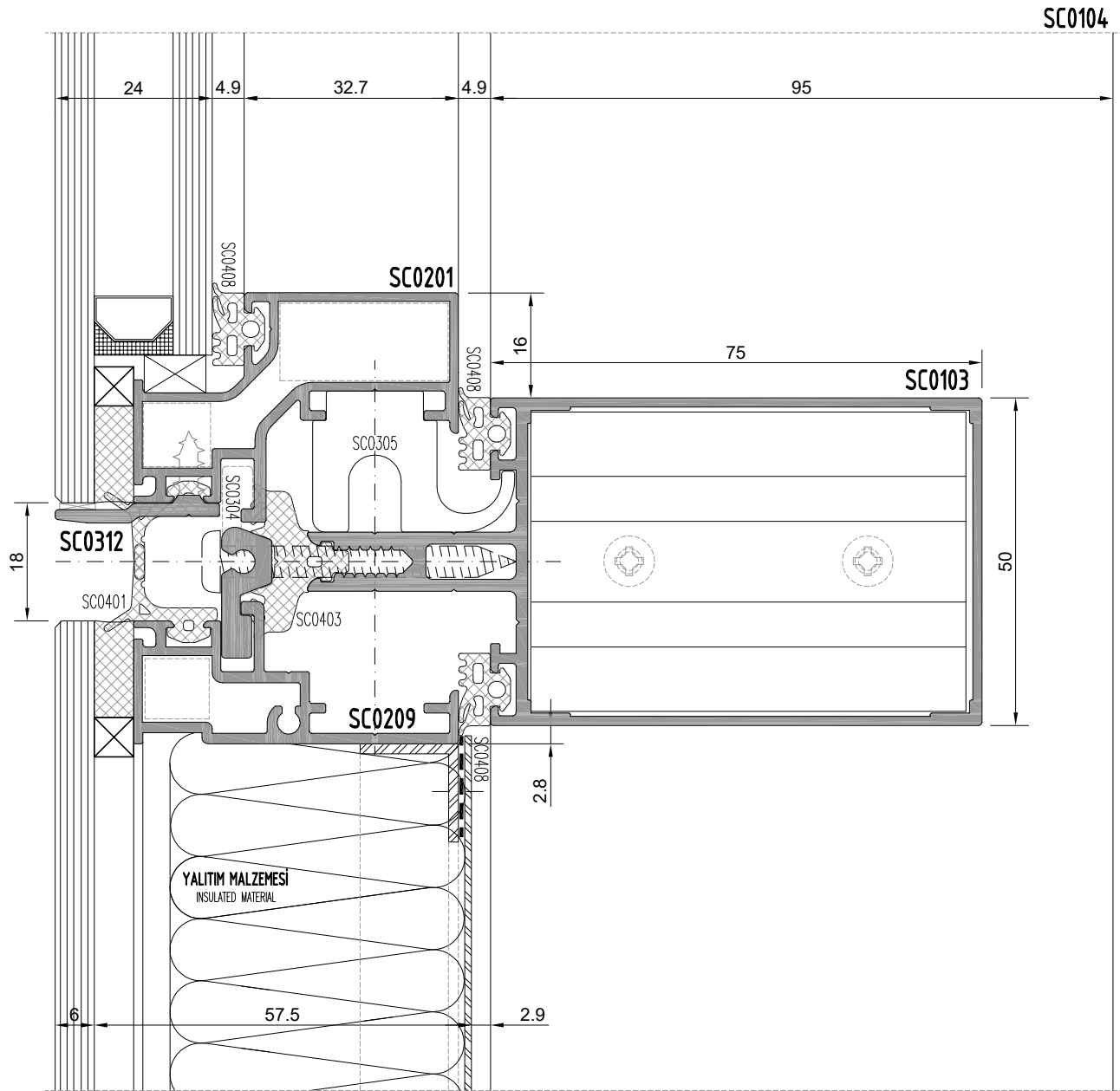
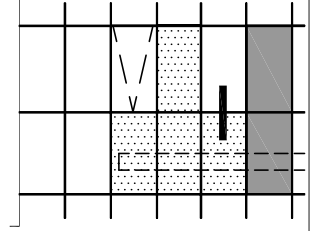

F50 KLASİK SİSTEM
SİLİKON CEPHE
F50 CLASSIC SYSTEM
SILICONE FACADE

KOMPOZİT - KOMPOZİT
COMPOSITE-COMPOSITE

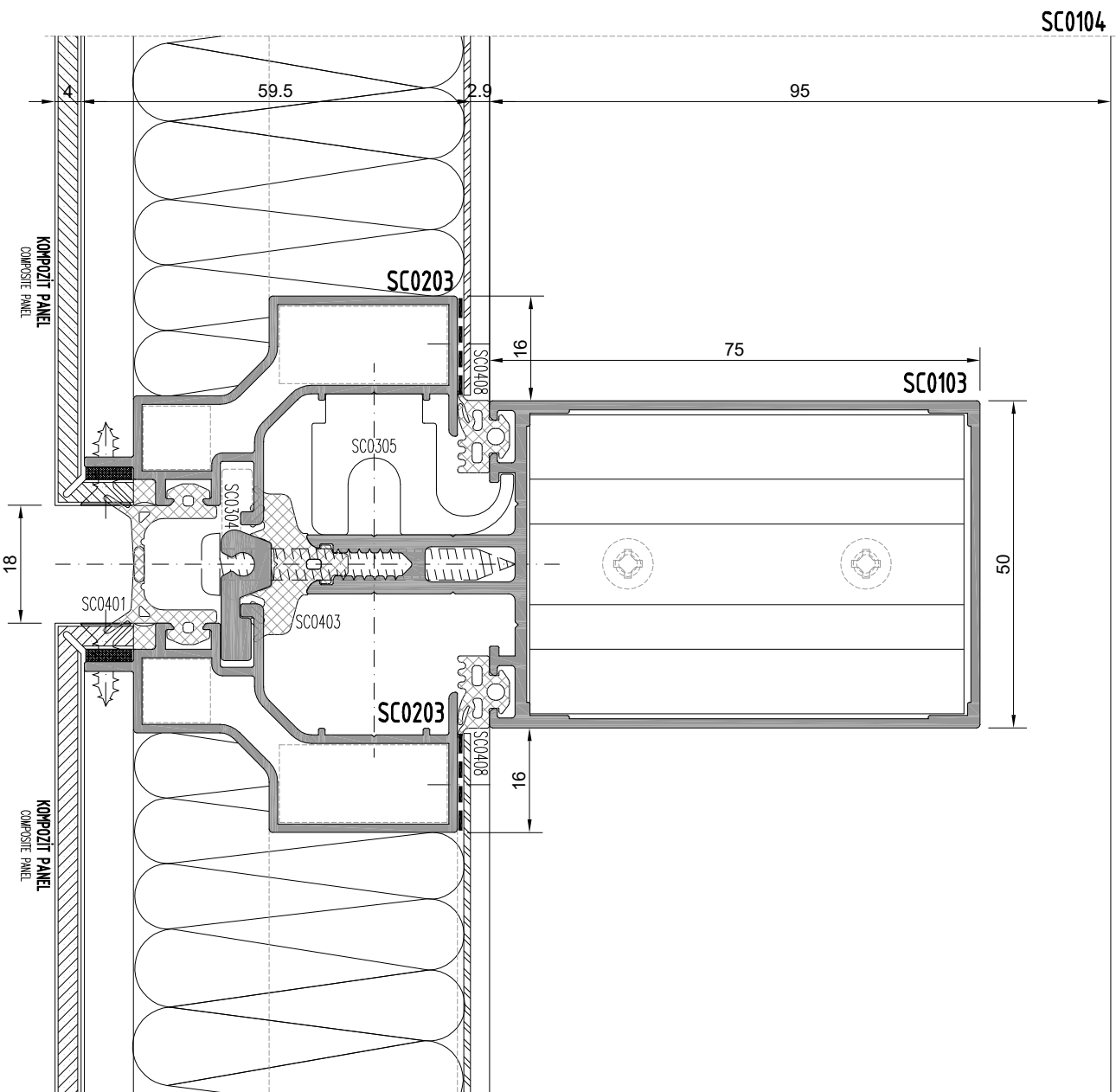
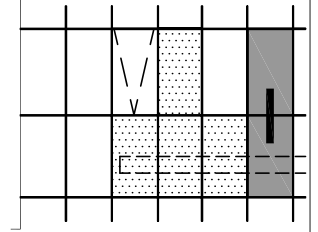

F50 KLASİK SİSTEM
SİLİKON CEPHE
F50 CLASSIC SYSTEM
SILICONE FACADE

KANAT - SPANDREL
SASH-SPANDREL

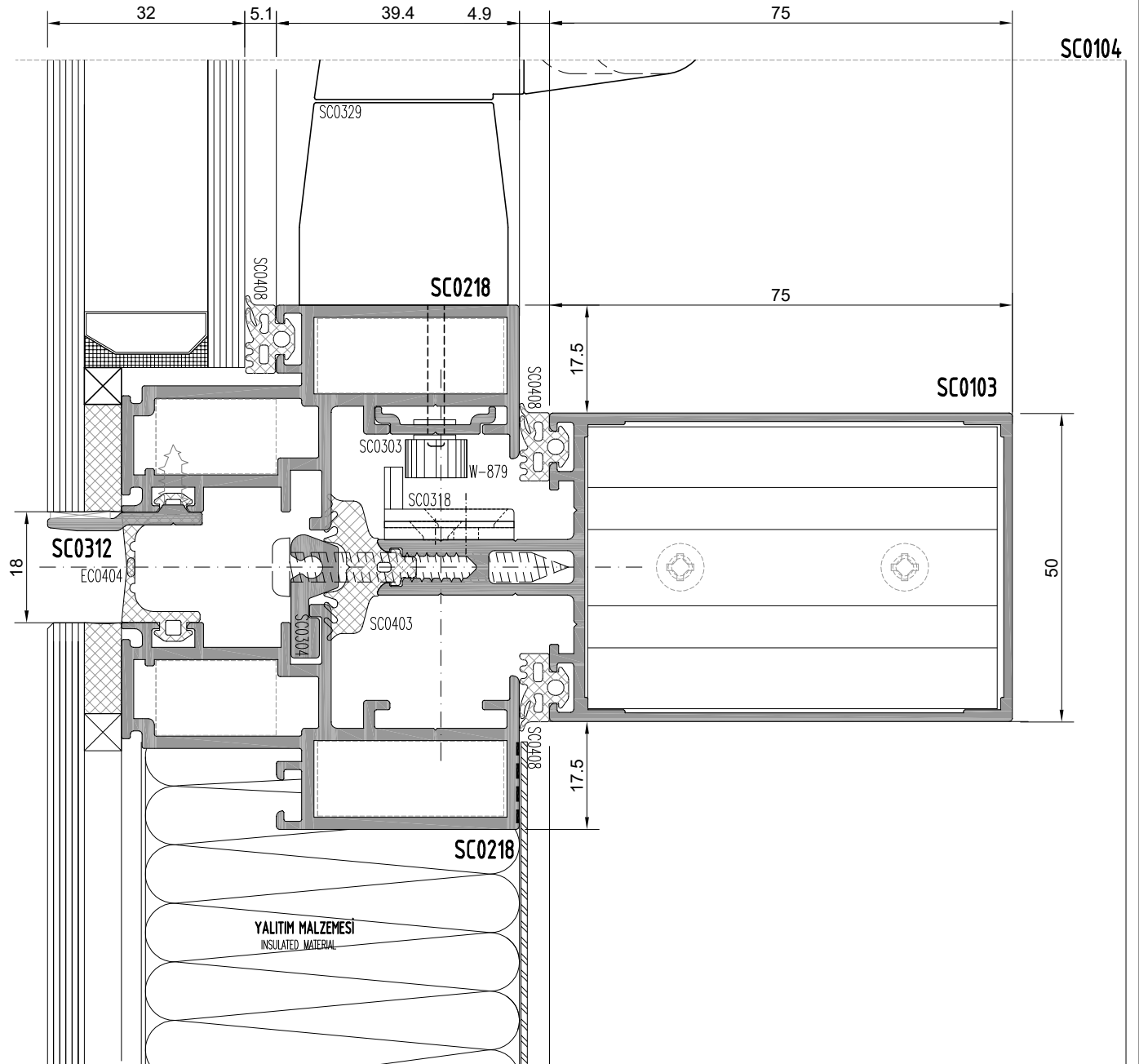
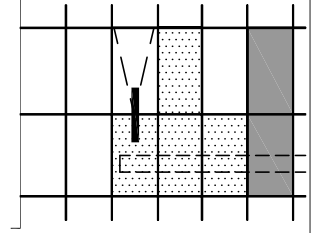

F50 KLASİK SİSTEM
SİLİKON CEPHE
F50 CLASSIC SYSTEM
SILICONE FACADE

SABİT - KOMPOZİT
FIXED-COMPOSITE

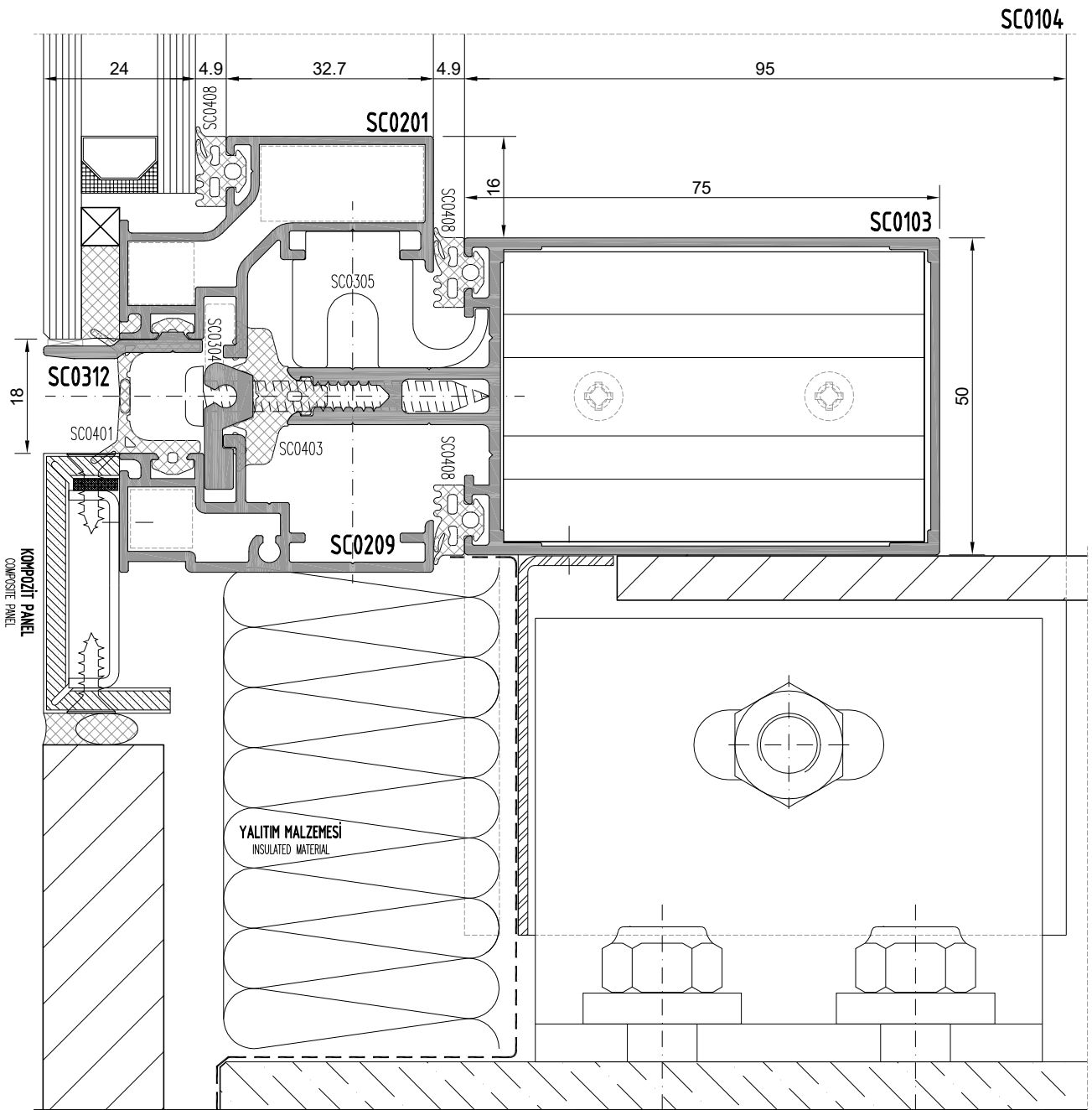
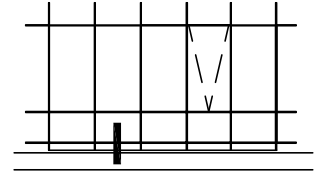

F50 KLASİK SİSTEM
SİLİKON CEPHE
F50 CLASSIC SYSTEM
SILICONE FACADE

KÖŞE DETAY
CORNER DETAIL

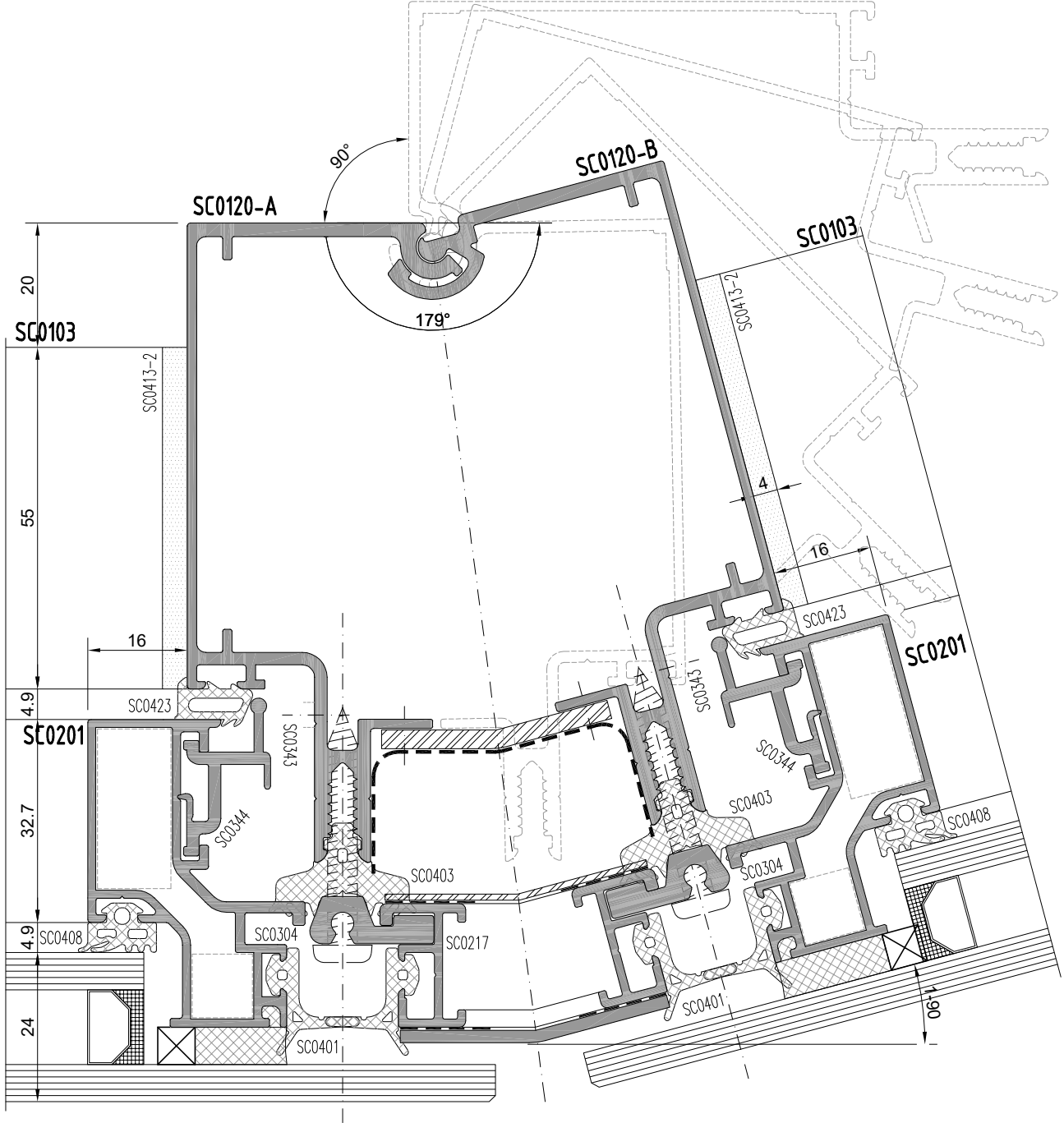
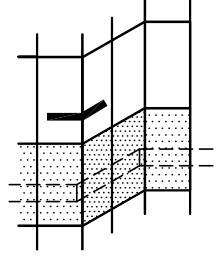

F50 KLASİK SİSTEM
SİLİKON CEPHE
F50 CLASSIC SYSTEM
SILICONE FACADE

KÖŞE DETAY
CORNER DETAIL

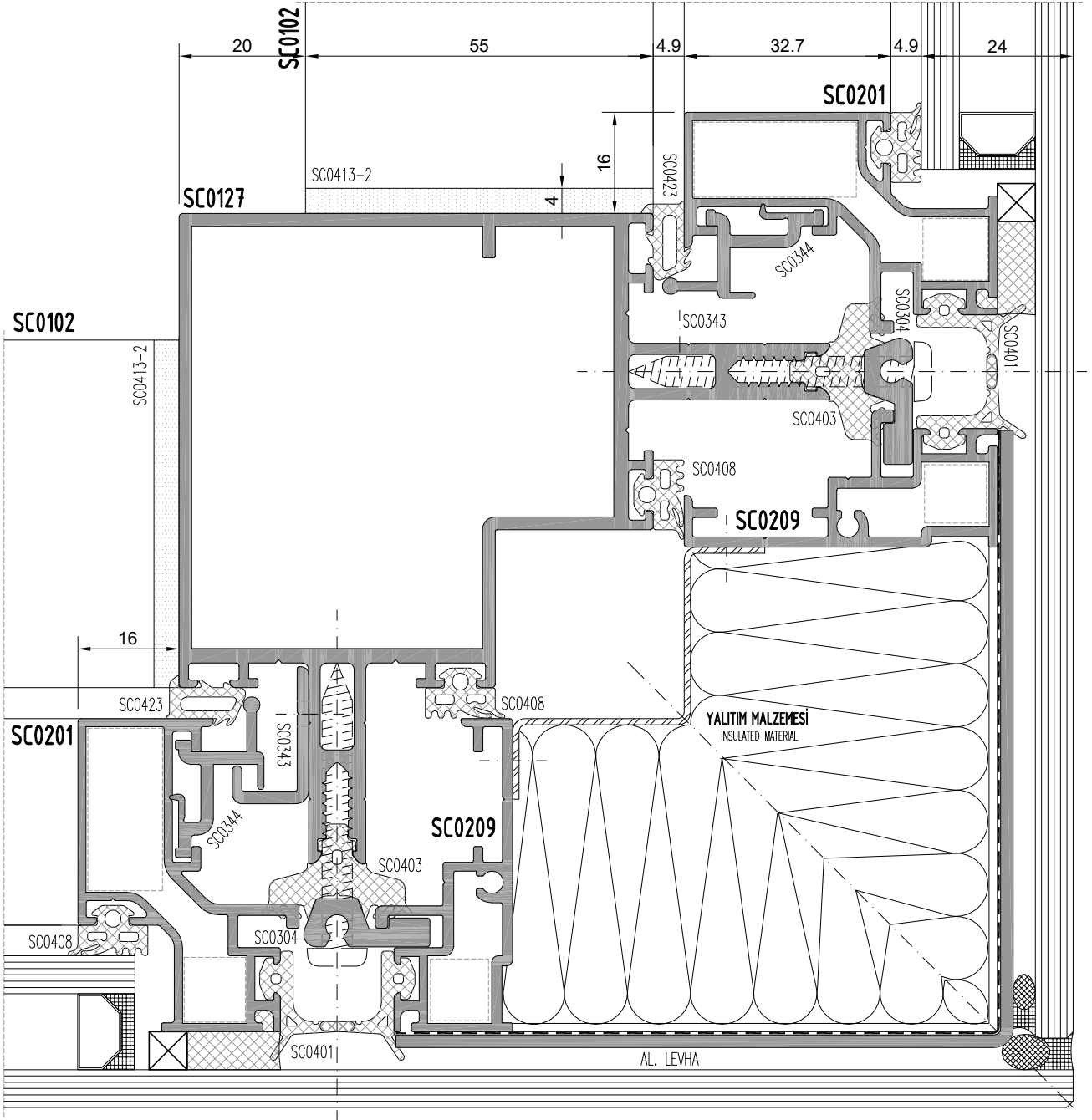
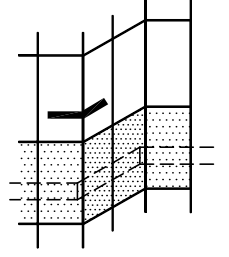

F50 KLASİK SİSTEM
SİLİKON CEPHE
F50 CLASSIC SYSTEM
SILICONE FACADE

YAN BİTİM - SABİT
WALL CONNECTION-FIXED

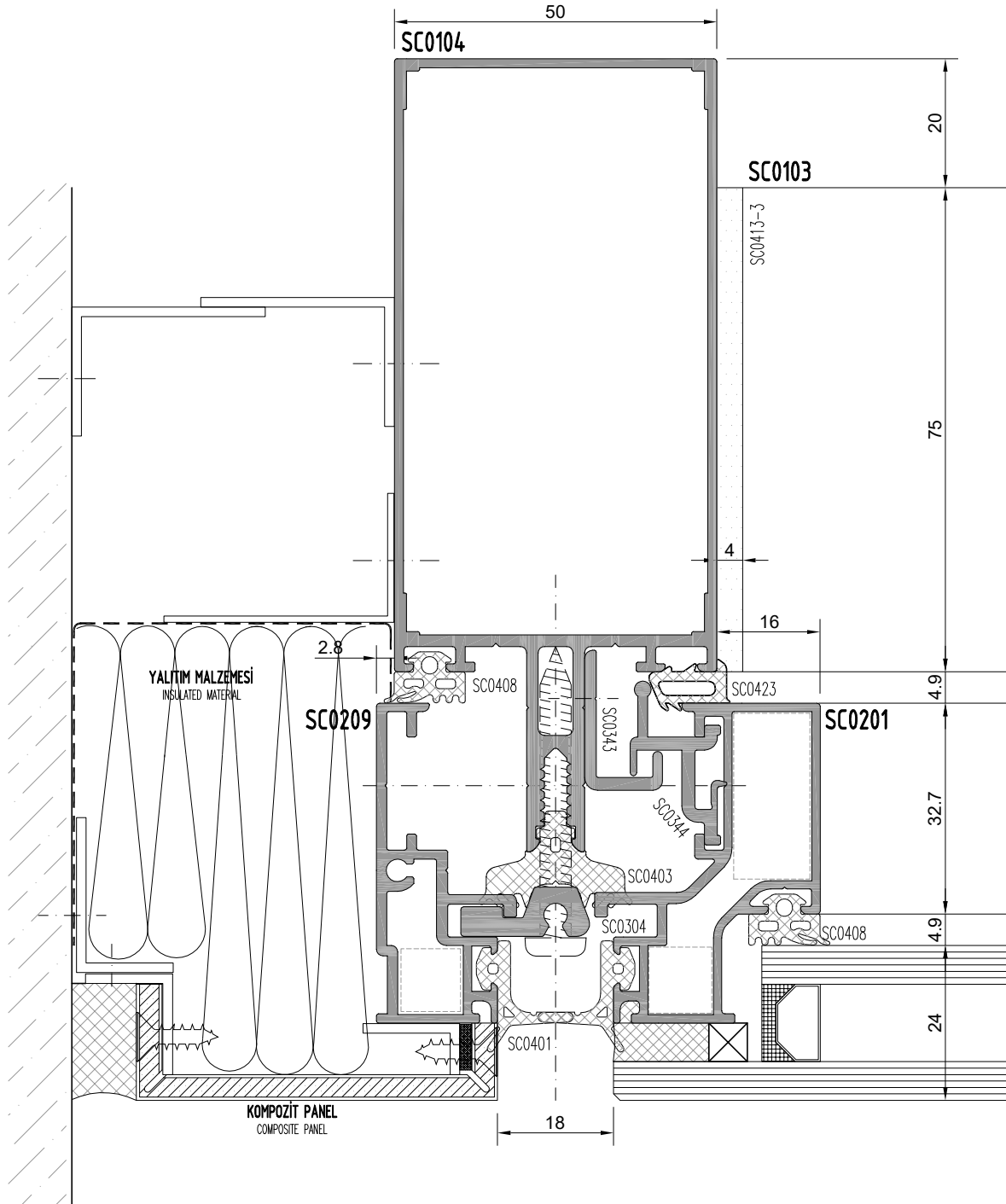
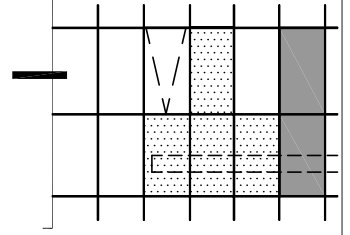

F50 KLASİK SİSTEM
SİLİKON CEPHE
F50 CLASSIC SYSTEM
SILICONE FACADE

SABİT - SABİT
FIXED-FIXED

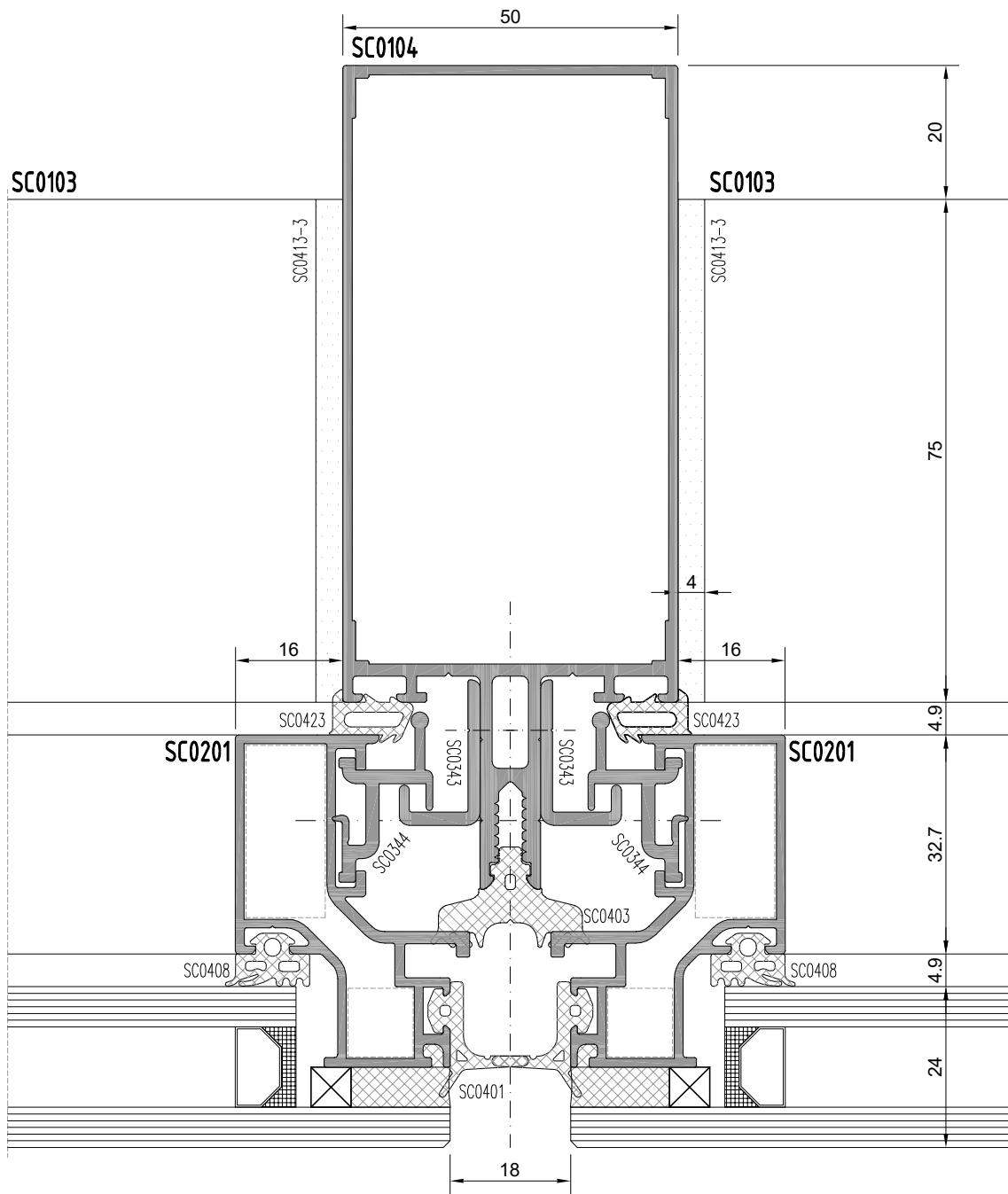
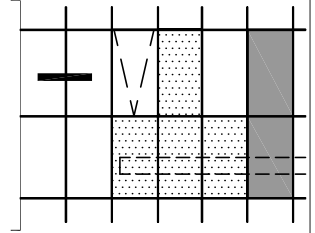

F50 KLASİK SİSTEM
SİLİKON CEPHE
F50 CLASSIC SYSTEM
SILICONE FACADE

KANAT - SPANDREL
SASH-SPANDREL

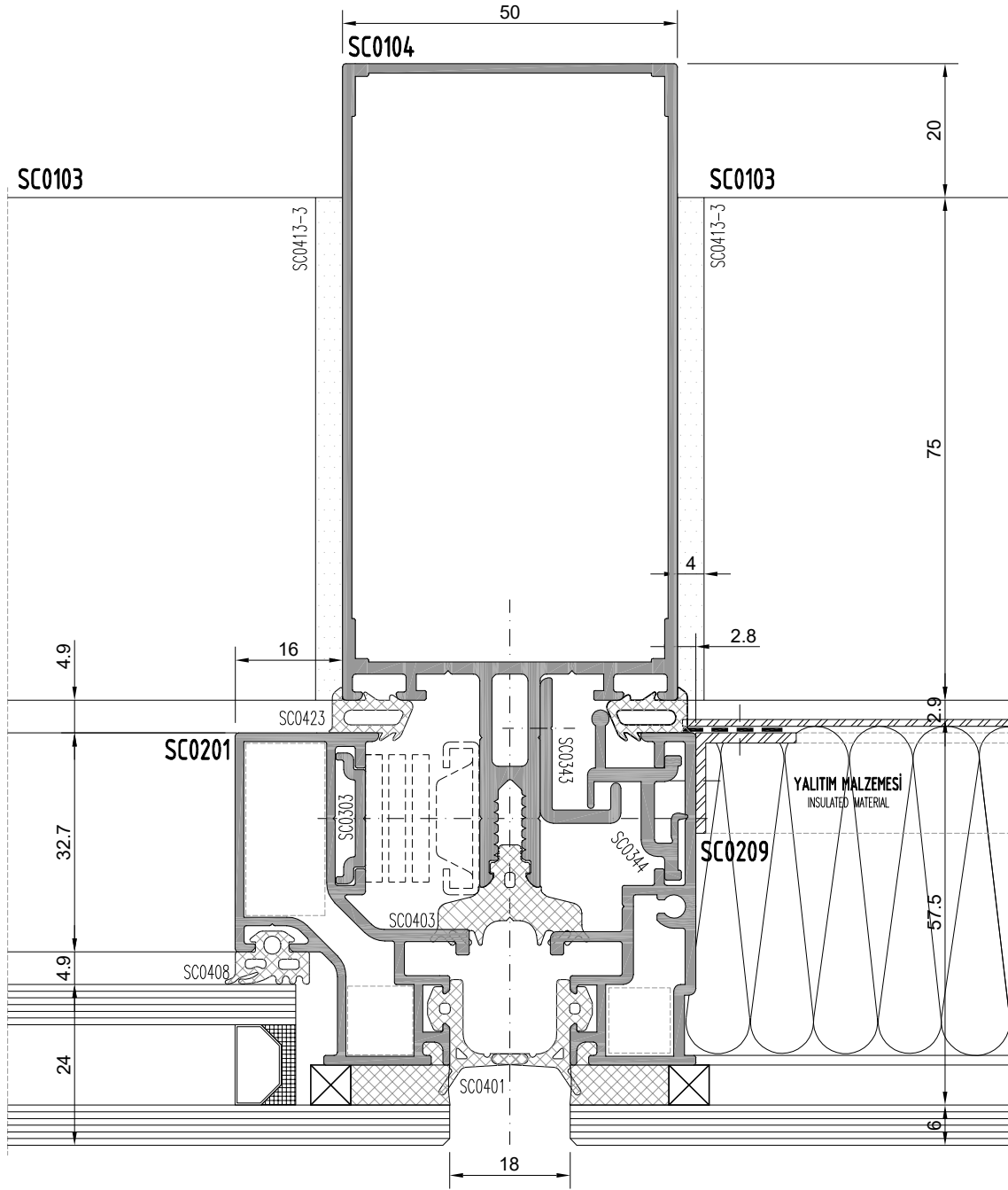
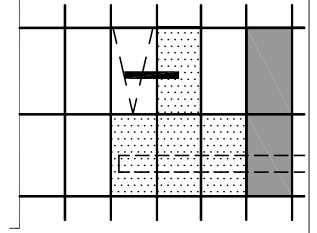

F50 KLASİK SİSTEM
SİLİKON CEPHE
F50 CLASSIC SYSTEM
SILICONE FACADE

SABİT - SPANDREL
FIXED-SPANDREL

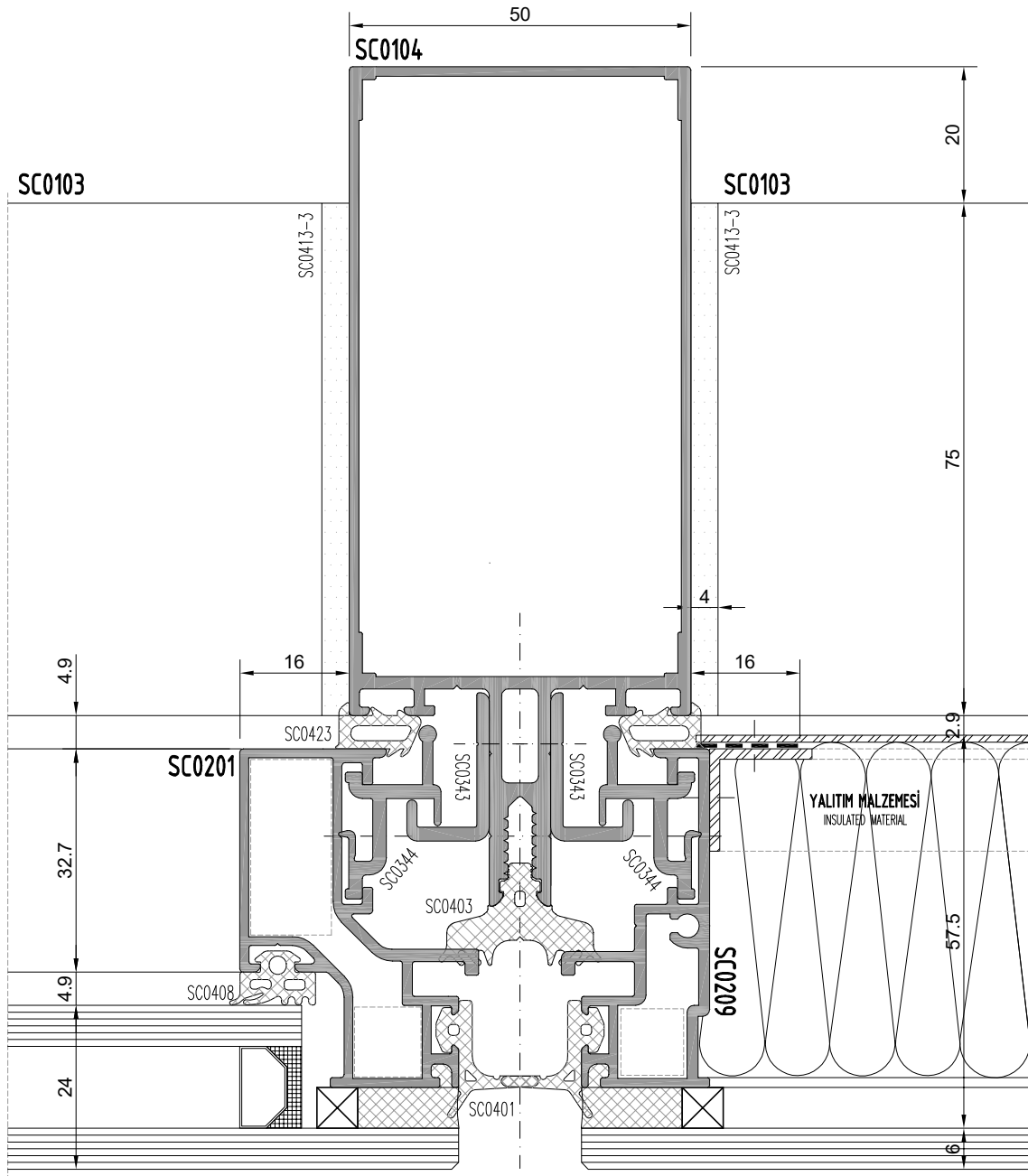
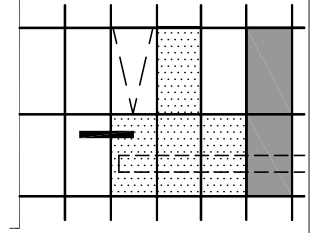

F50 KLASİK SİSTEM
SİLİKON CEPHE
F50 CLASSIC SYSTEM
SILICONE FACADE

SABIT - KANAT
FIXED-SASH

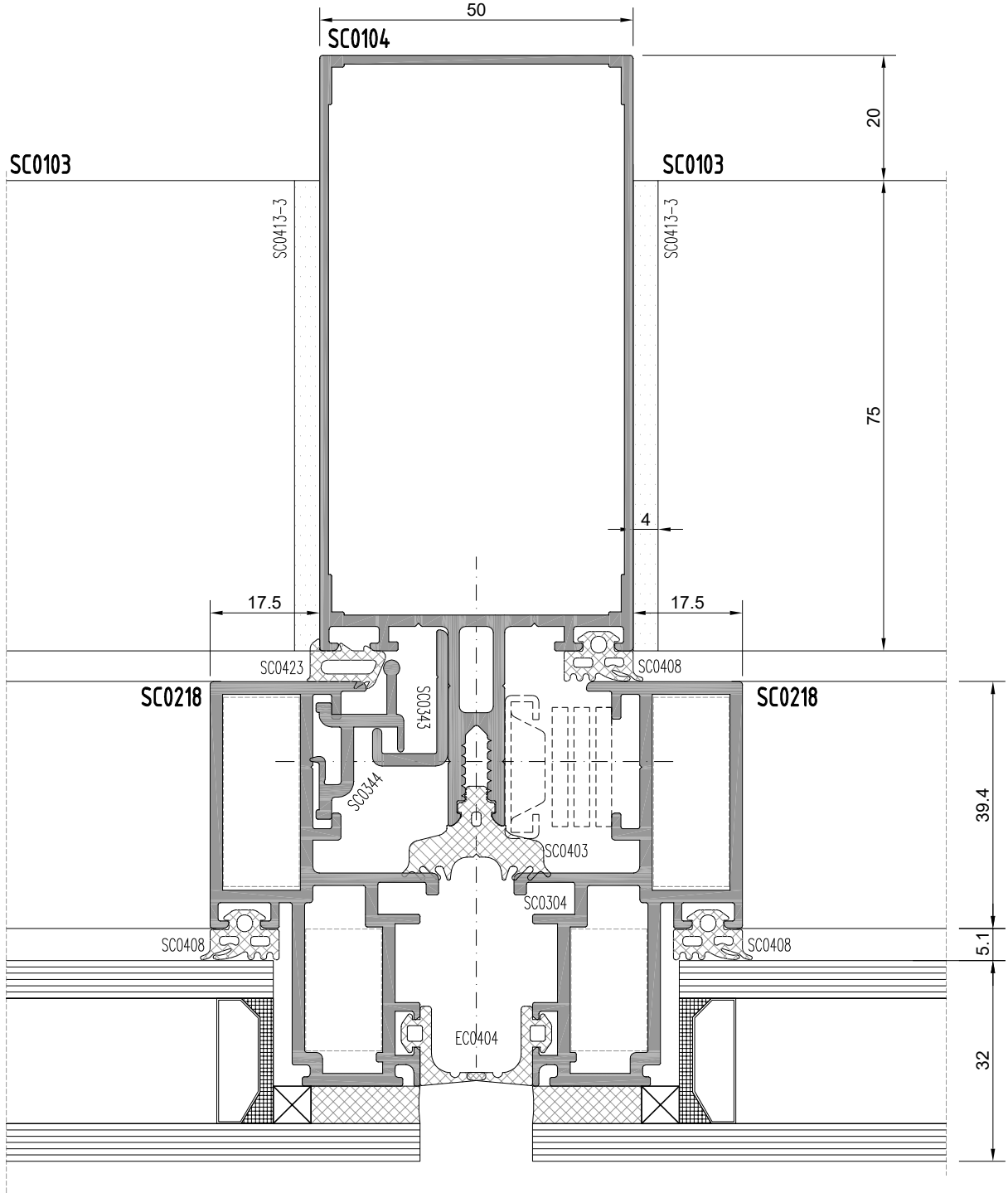
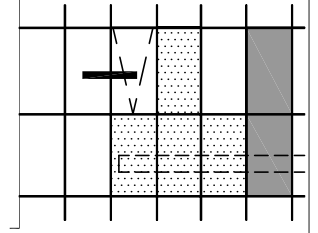

F50 KLASİK SİSTEM
SİLİKON CEPHE
F50 CLASSIC SYSTEM
SILICONE FACADE

SABİT - SABİT
FIXED-FIXED

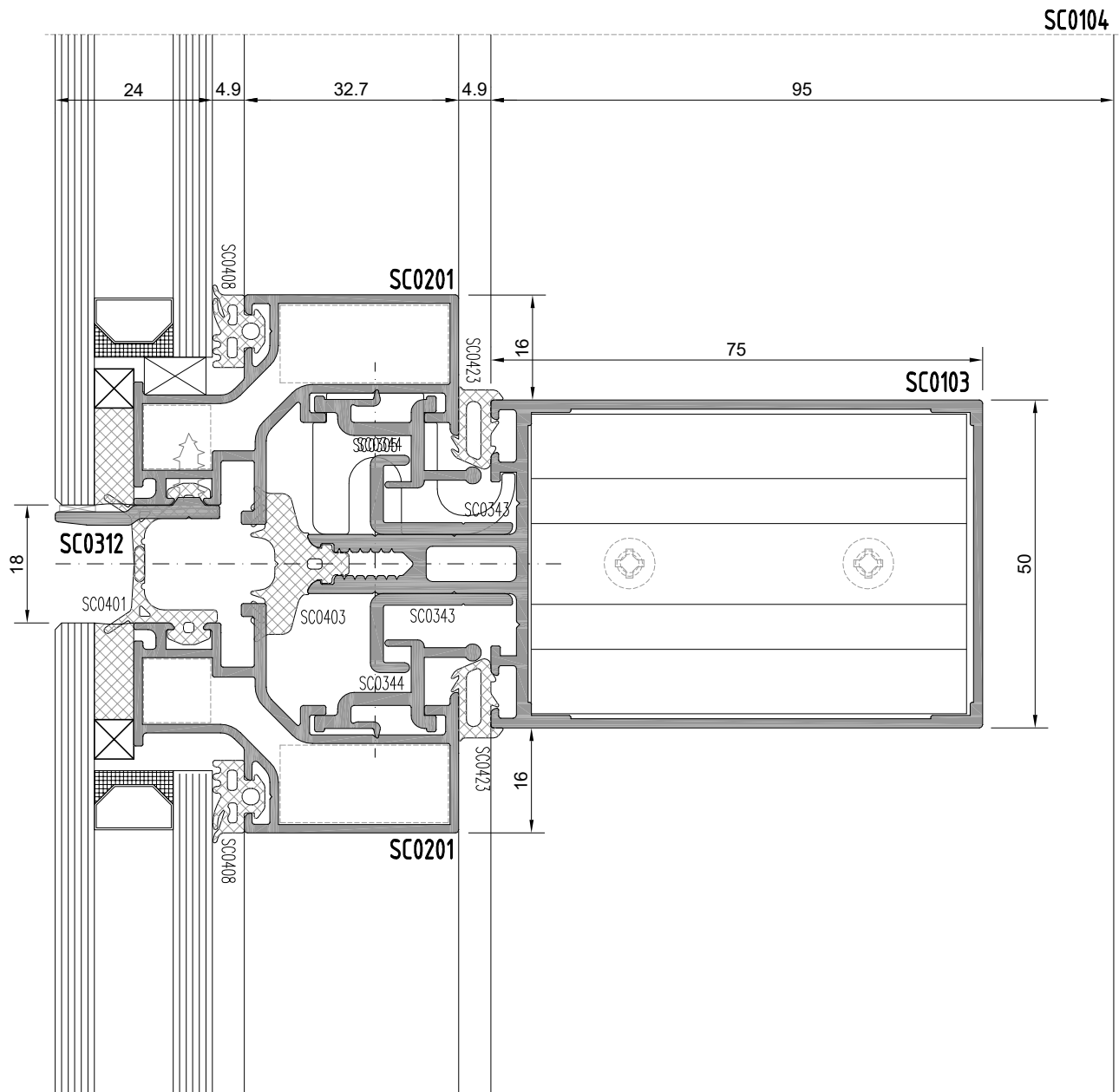
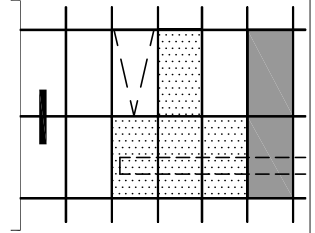

F50 KLASİK SİSTEM
SİLİKON CEPHE
F50 CLASSIC SYSTEM
SILICONE FACADE

SABİT - SPANDREL
FIXED-SPANDREL

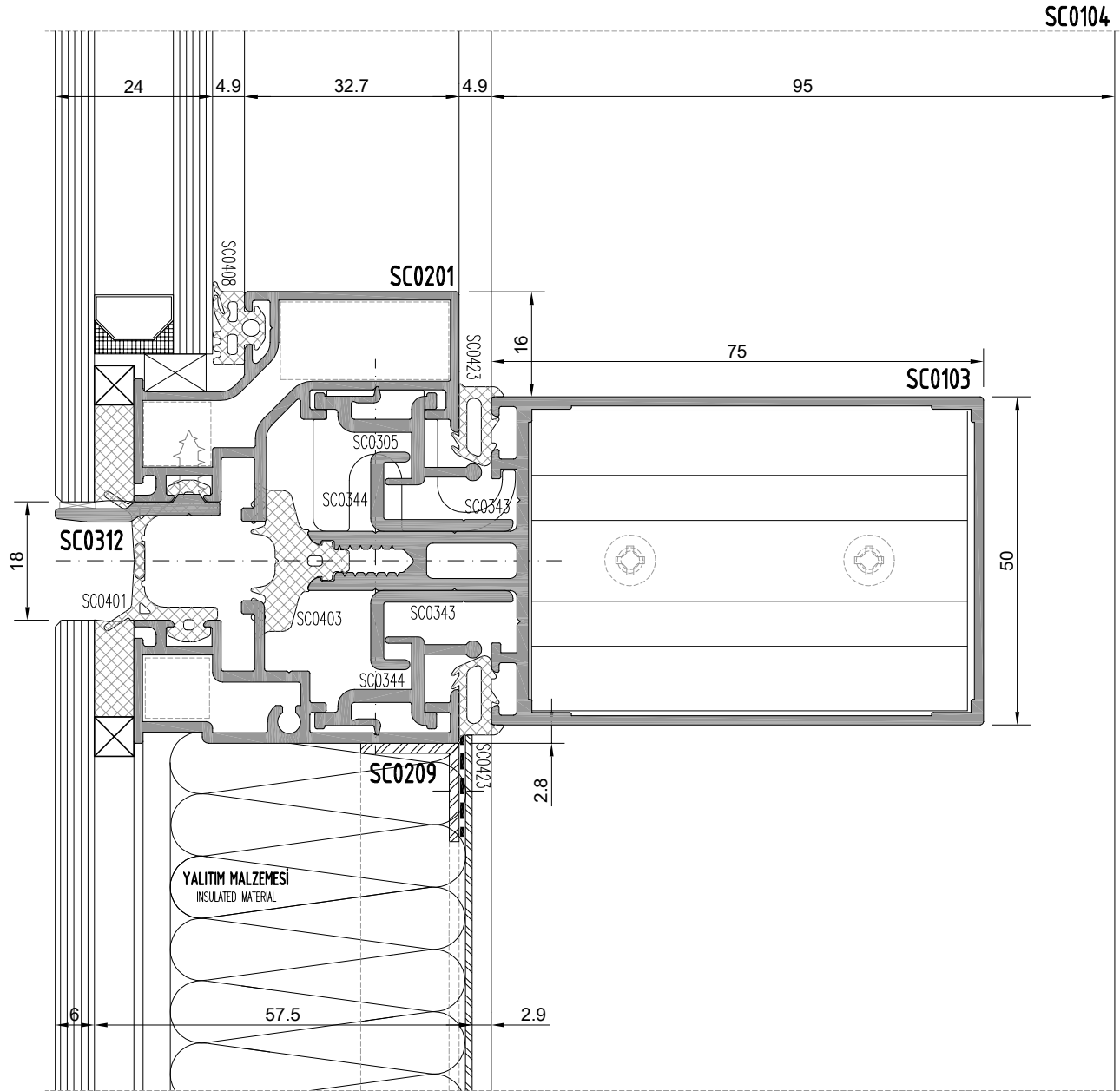
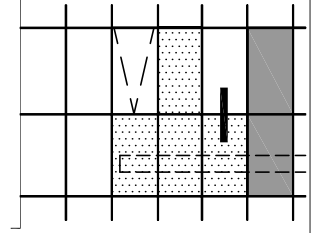

F50 KLASİK SİSTEM
SİLİKON CEPHE
F50 CLASSIC SYSTEM
SILICONE FACADE

KANAT - SPANDREL
SASH-SPANDREL

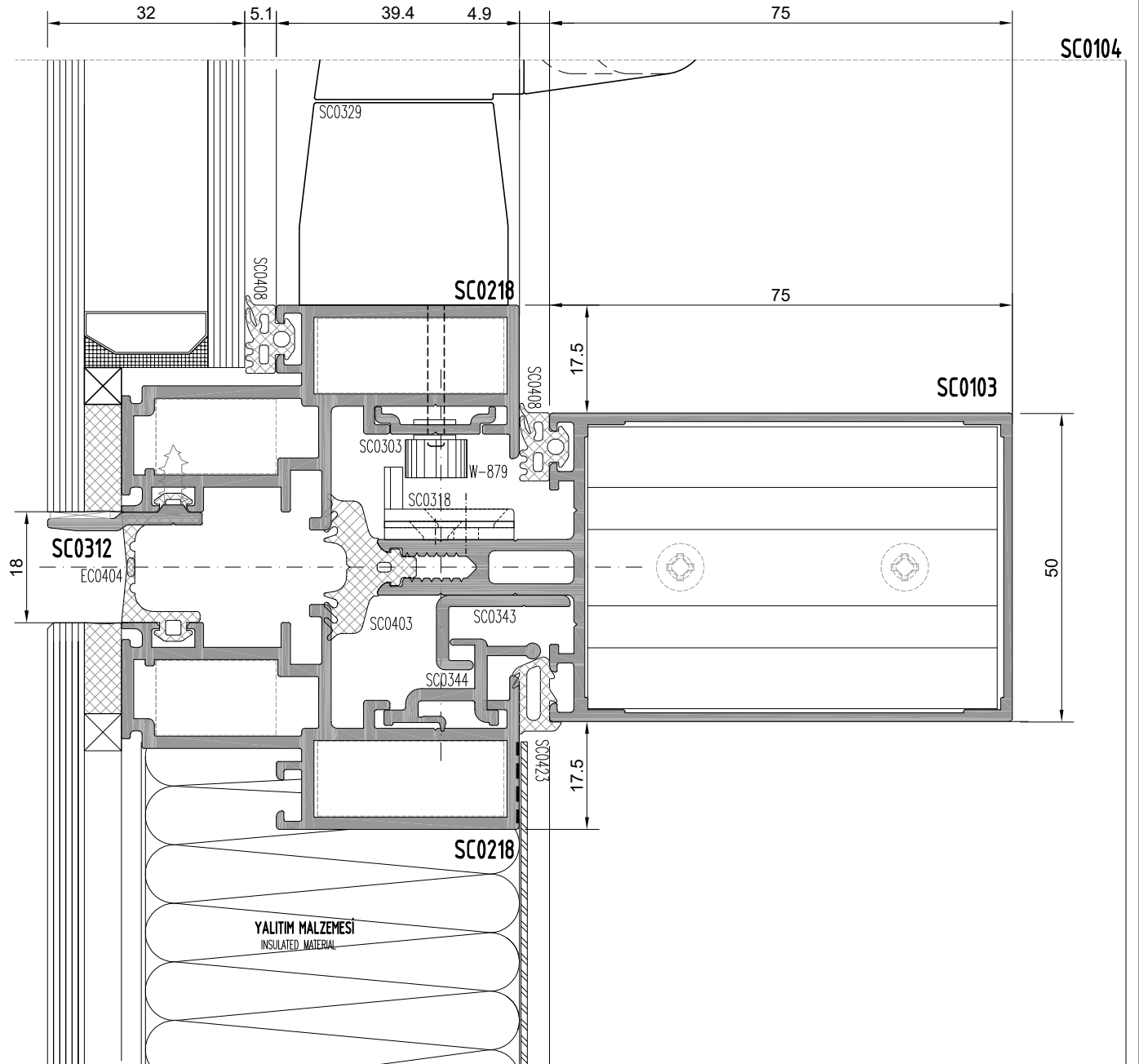
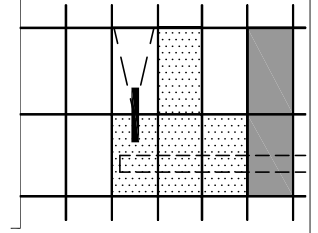

F50 KLASİK SİSTEM
SİLİKON CEPHE
F50 CLASSIC SYSTEM
SILICONE FACADE

SABİT - KOMPOZİT
FIXED-COMPOSITE

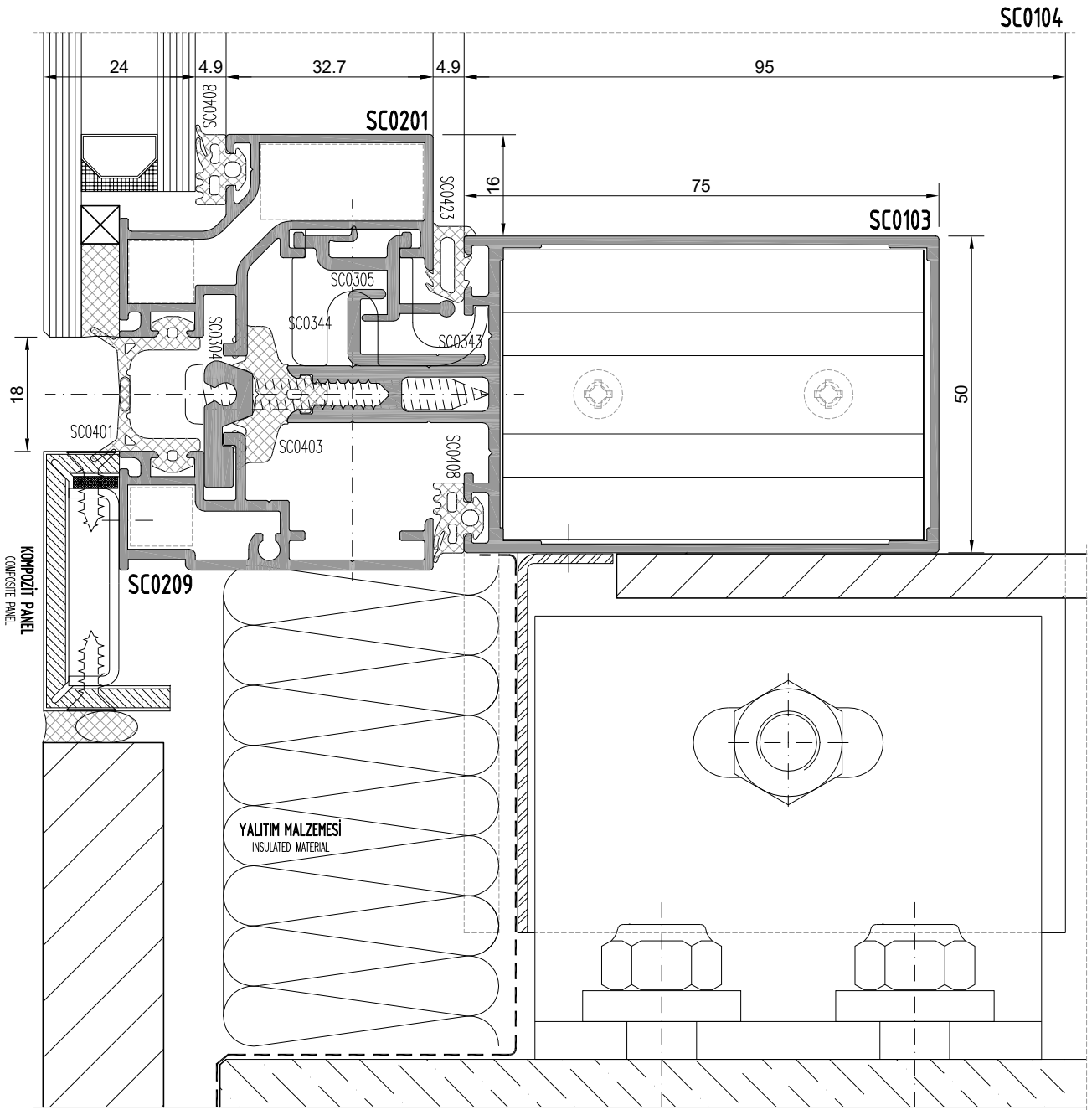
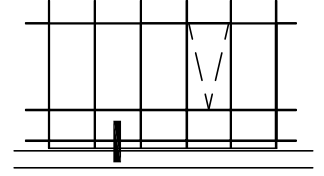

F50 KLASİK SİSTEM
SİLİKON CEPHE
F50 CLASSIC SYSTEM
SILICONE FACADE

SABİT - SABİT
FIXED-FIXED

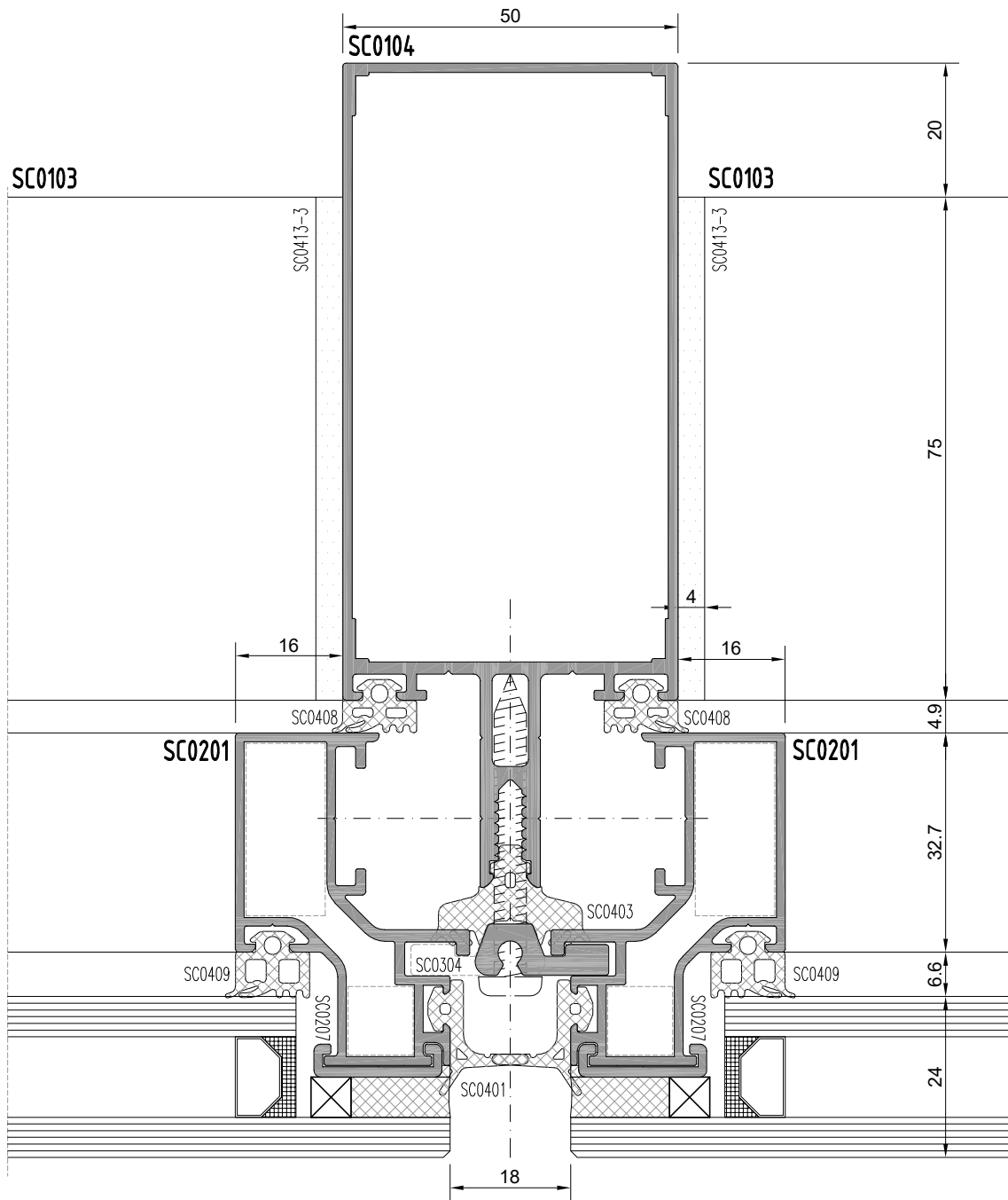
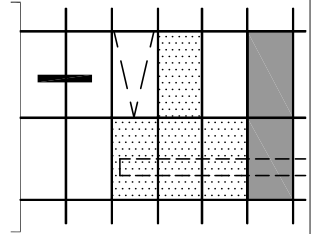

F50 KLASİK SİSTEM
SİLİKON CEPHE
F50 CLASSIC SYSTEM
SILICONE FACADE

SABİT - KANAT
FIXED-SASH

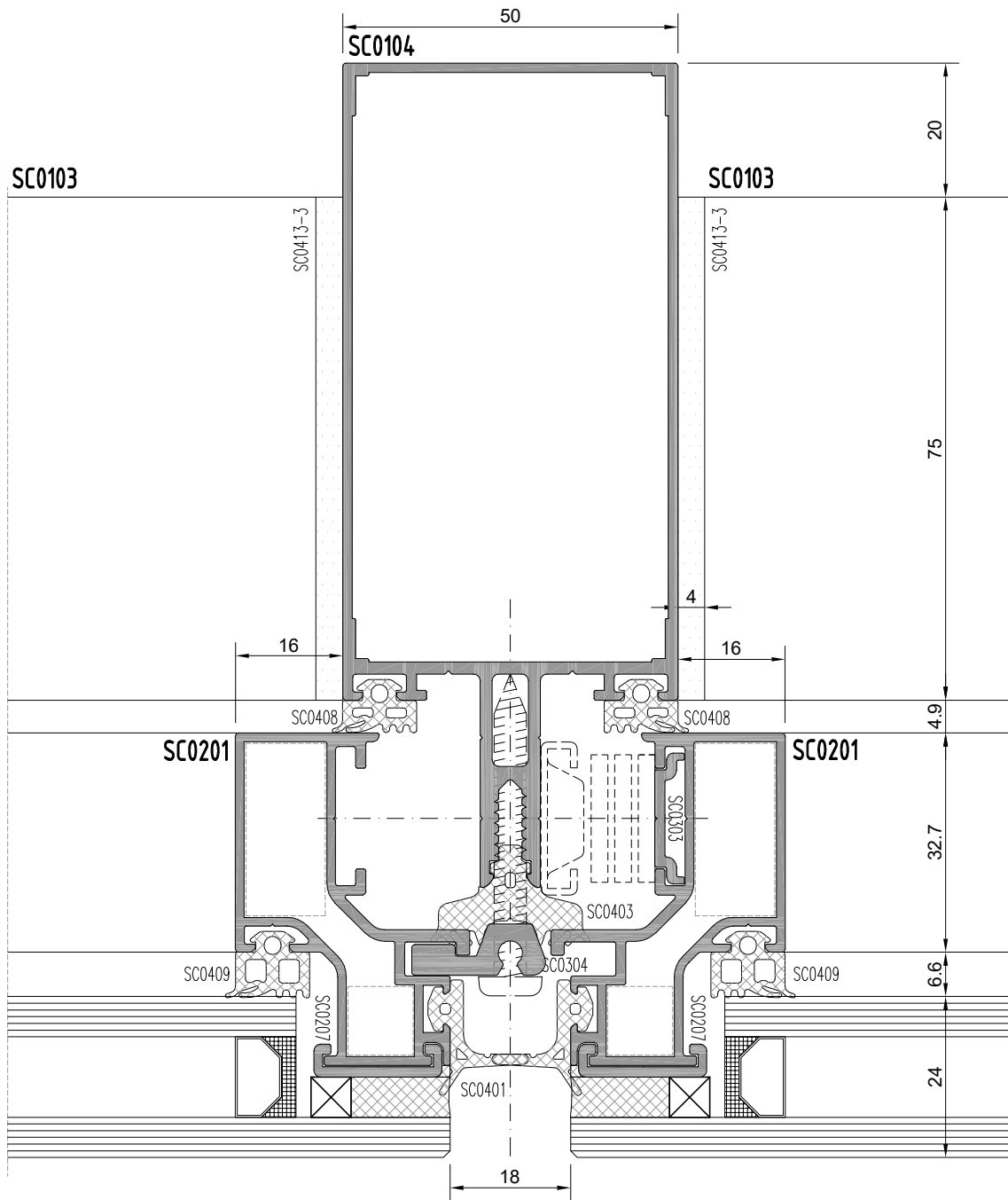
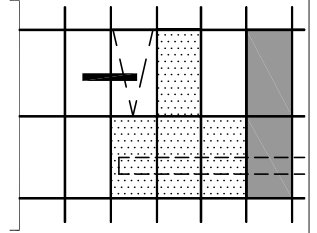

F50 KLASİK SİSTEM
SİLİKON CEPHE
F50 CLASSIC SYSTEM
SILICONE FACADE

KANAT - SPANDREL
SASH-SPANDREL

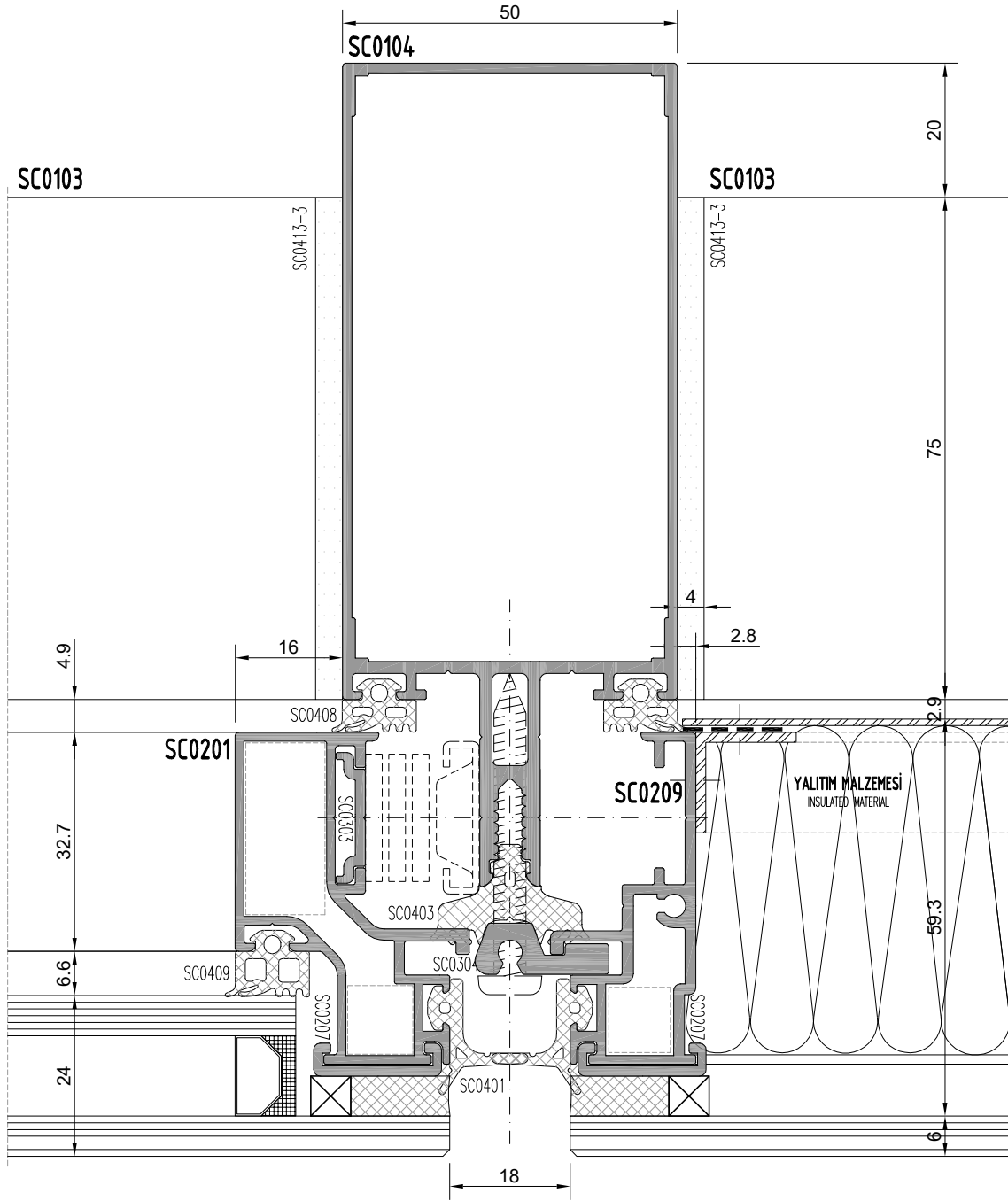
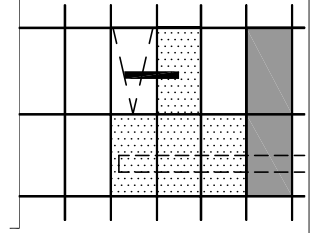

F50 KLASİK SİSTEM
SİLİKON CEPHE
F50 CLASSIC SYSTEM
SILICONE FACADE

SPANDREL - SABİT
SPANDREL-FIXED

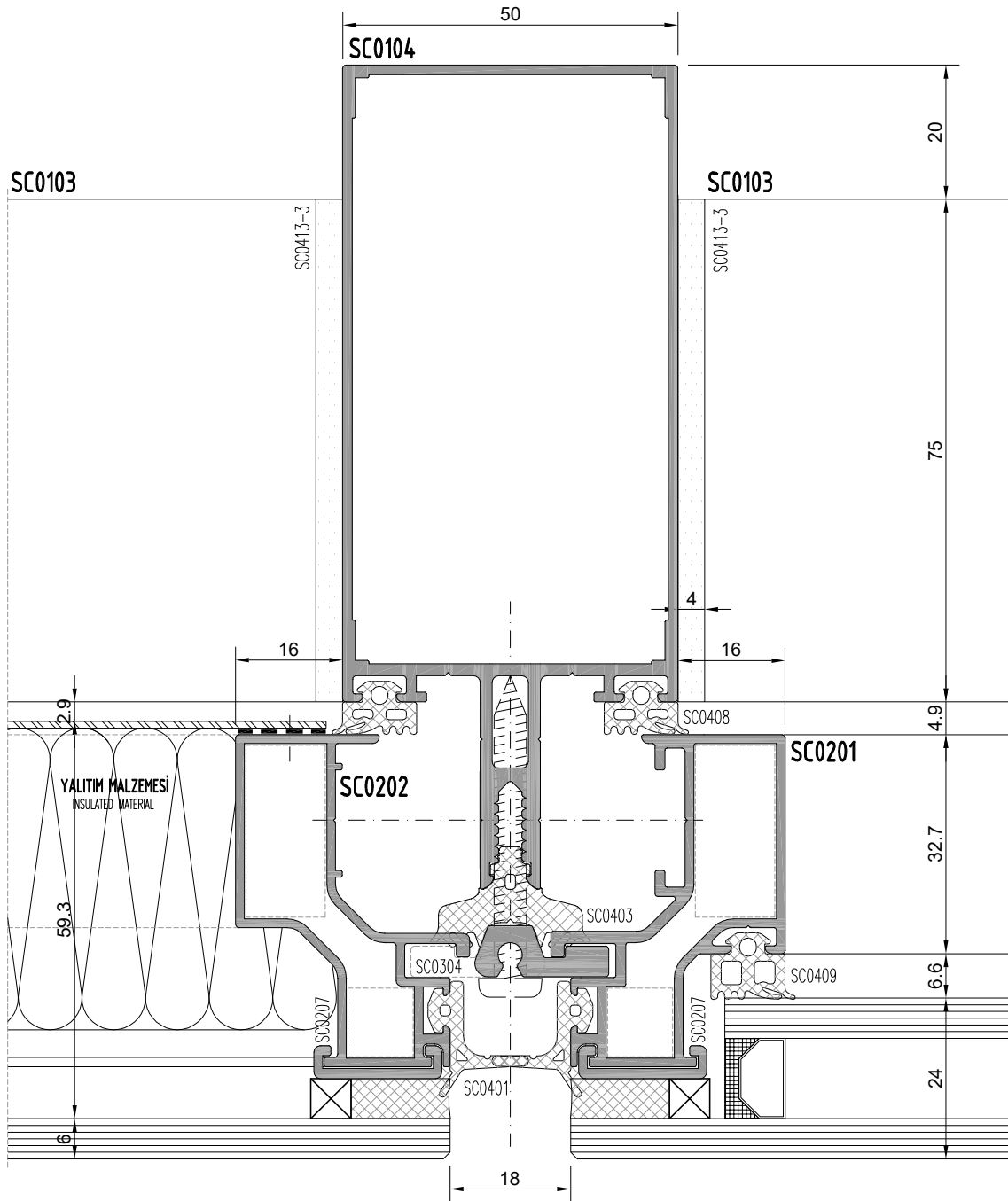
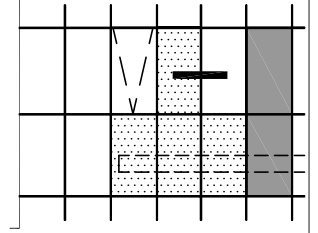

F50 KLASİK SİSTEM
SİLİKON CEPHE
F50 CLASSIC SYSTEM
SILICONE FACADE

SABİT - KOMPOZİT
FIXED-COMPOSITE

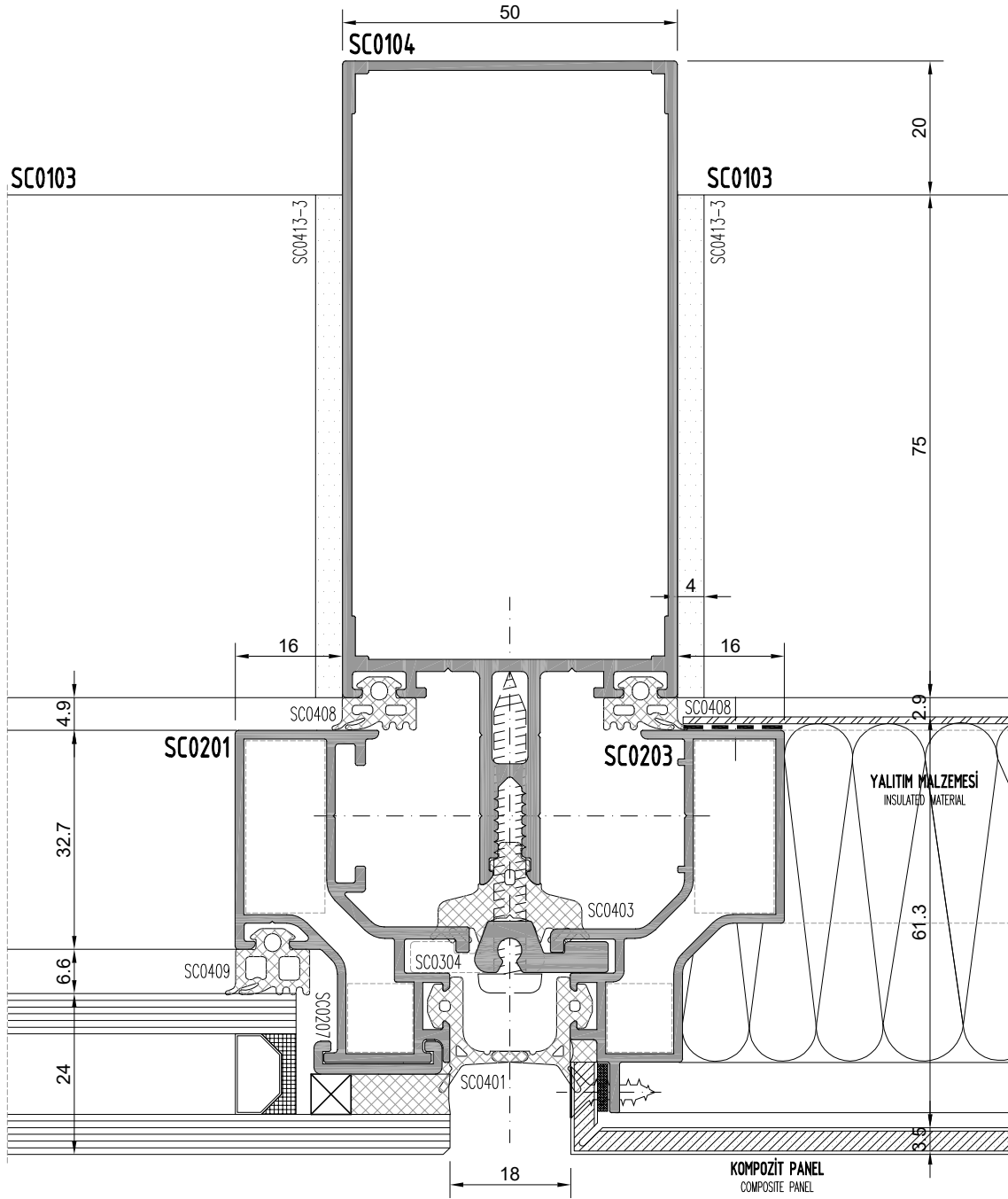
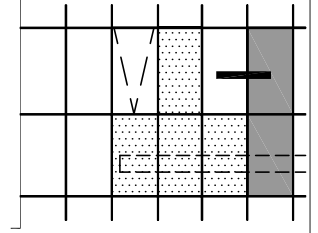

F50 KLASİK SİSTEM
SİLİKON CEPHE
F50 CLASSIC SYSTEM
SILICONE FACADE

SABIT - KANAT
FIXED-SASH

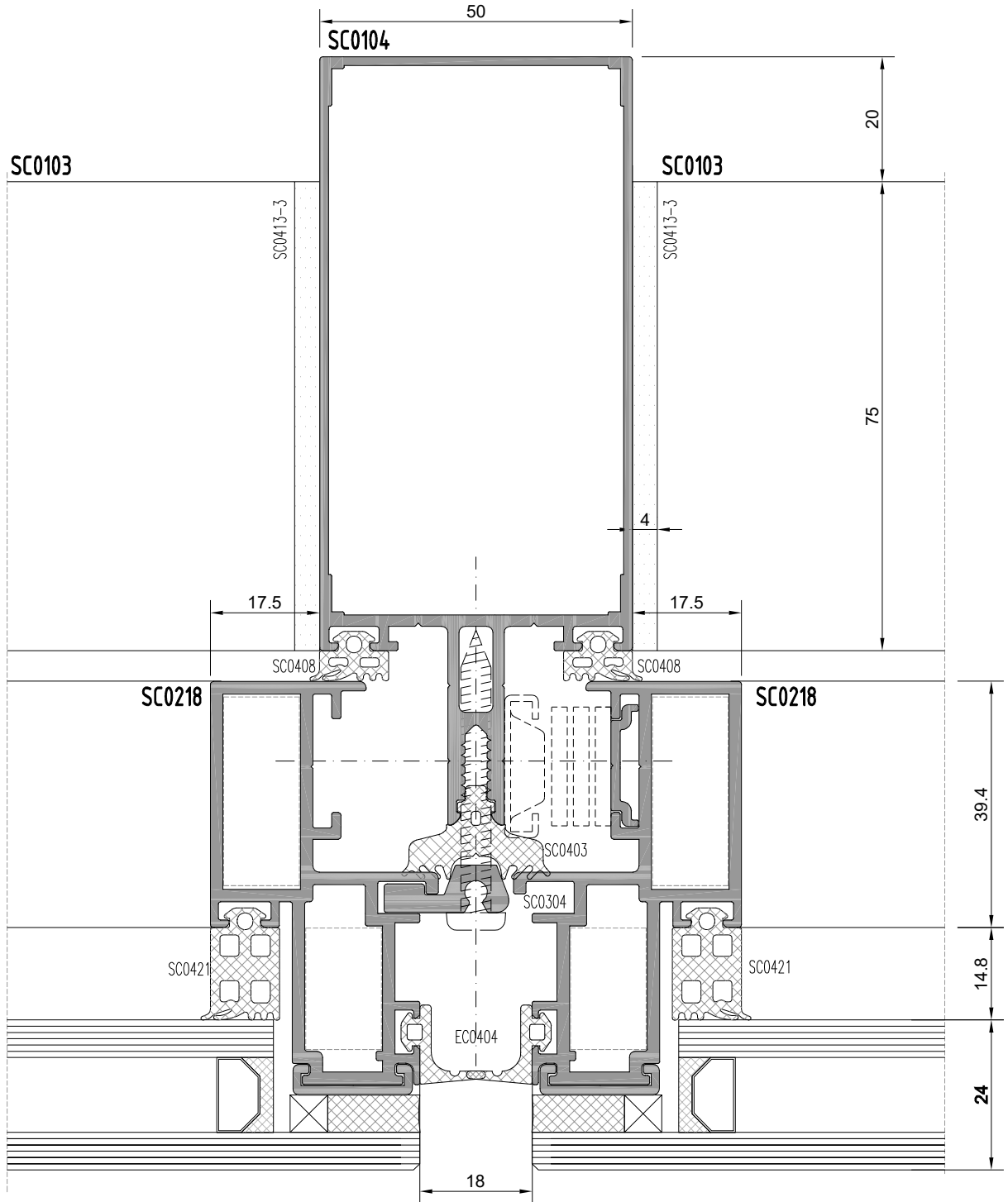
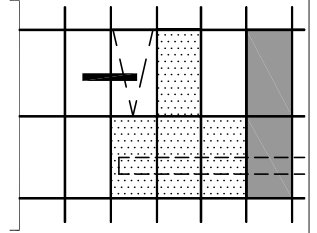

F50 KLASİK SİSTEM
SİLİKON CEPHE
F50 CLASSIC SYSTEM
SILICONE FACADE

SABİT - SPANDREL
FIXED-SPANDREL

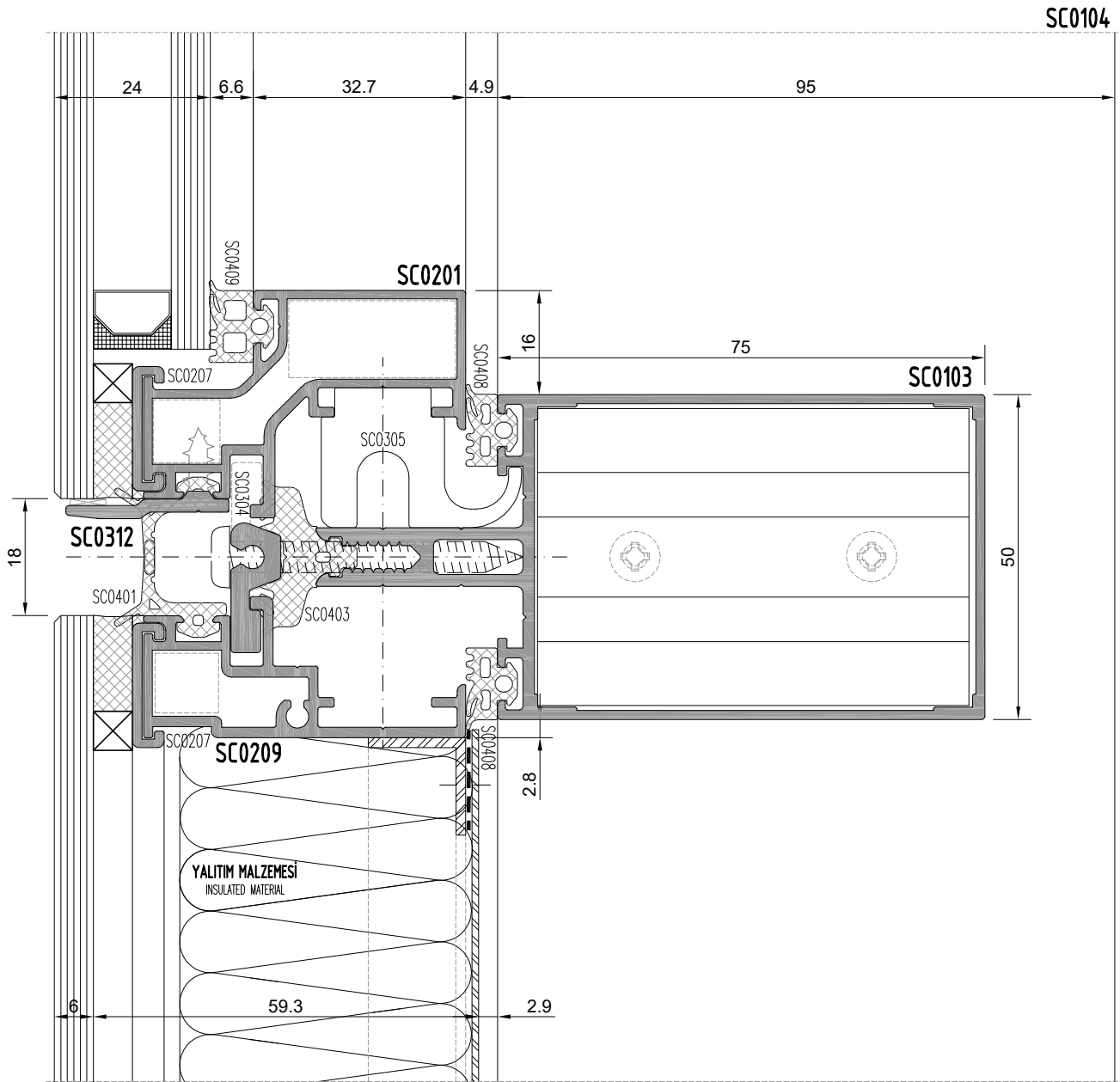
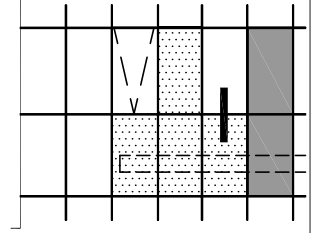

F50 KLASİK SİSTEM
SİLİKON CEPHE
F50 CLASSIC SYSTEM
SILICONE FACADE

KANAT - SPANDREL
SASH-SPANDREL

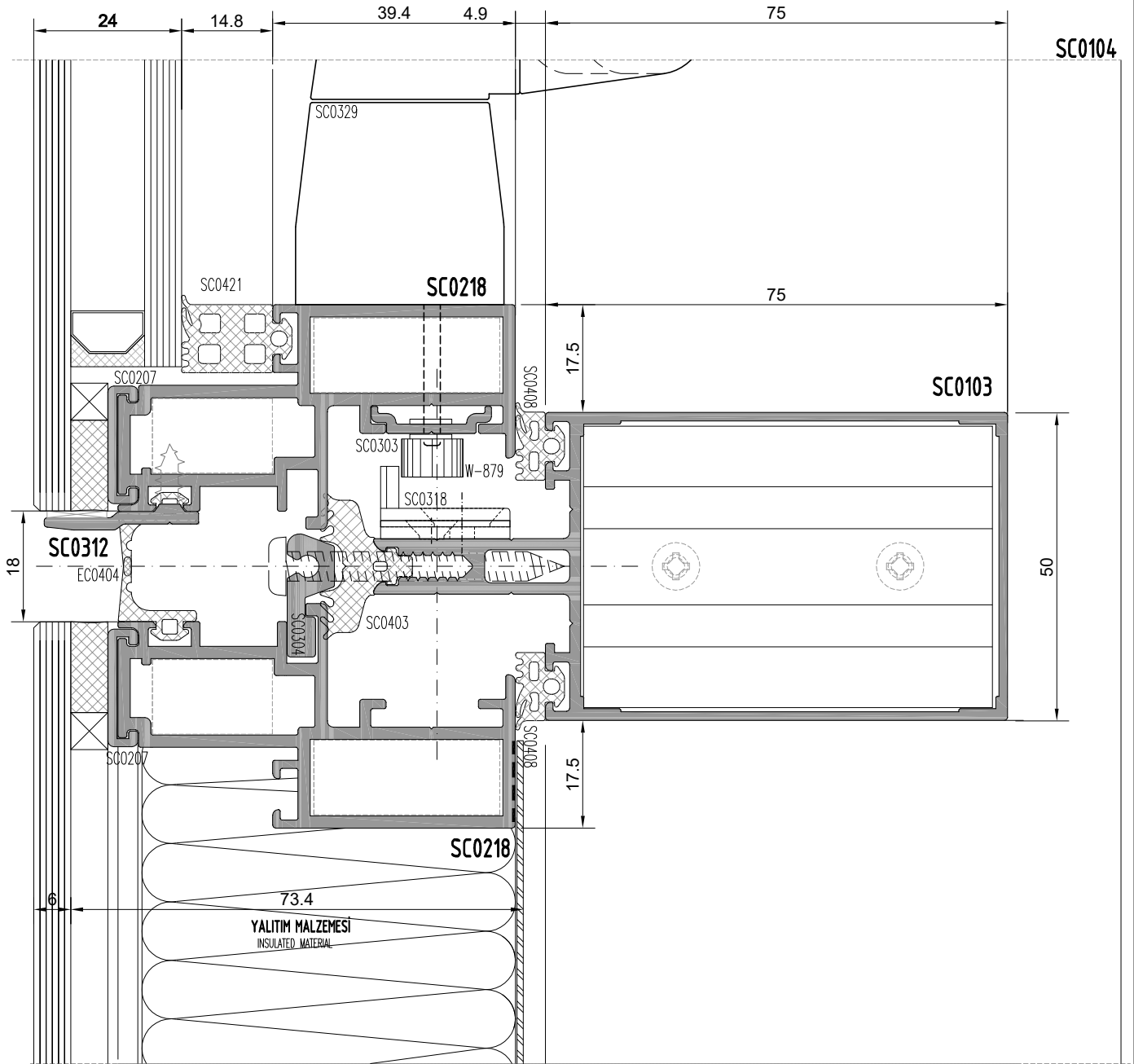
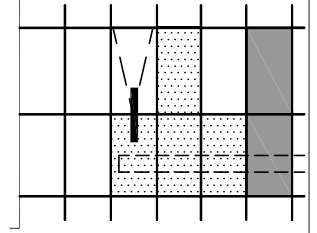

F50 KLASİK SİSTEM
SİLİKON CEPHE
F50 CLASSIC SYSTEM
SILICONE FACADE

SABİT - SABİT
FIXED-FIXED

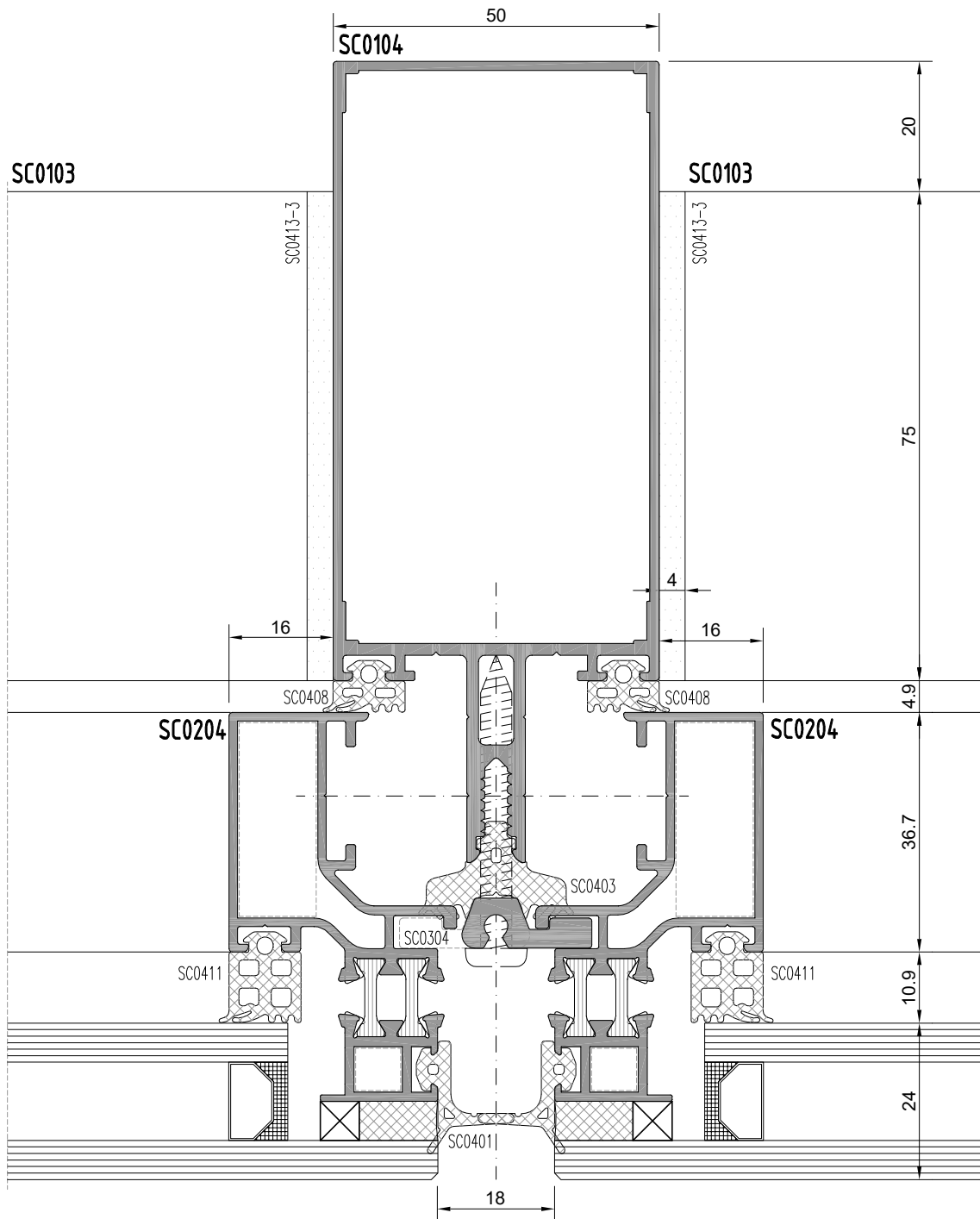
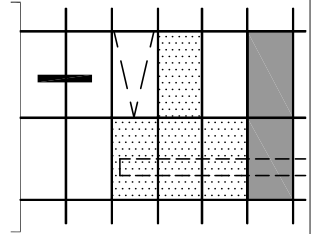

F50 KLASİK SİSTEM
SİLİKON CEPHE
F50 CLASSIC SYSTEM
SILICONE FACADE

SABİT - KANAT
FIXED-SASH

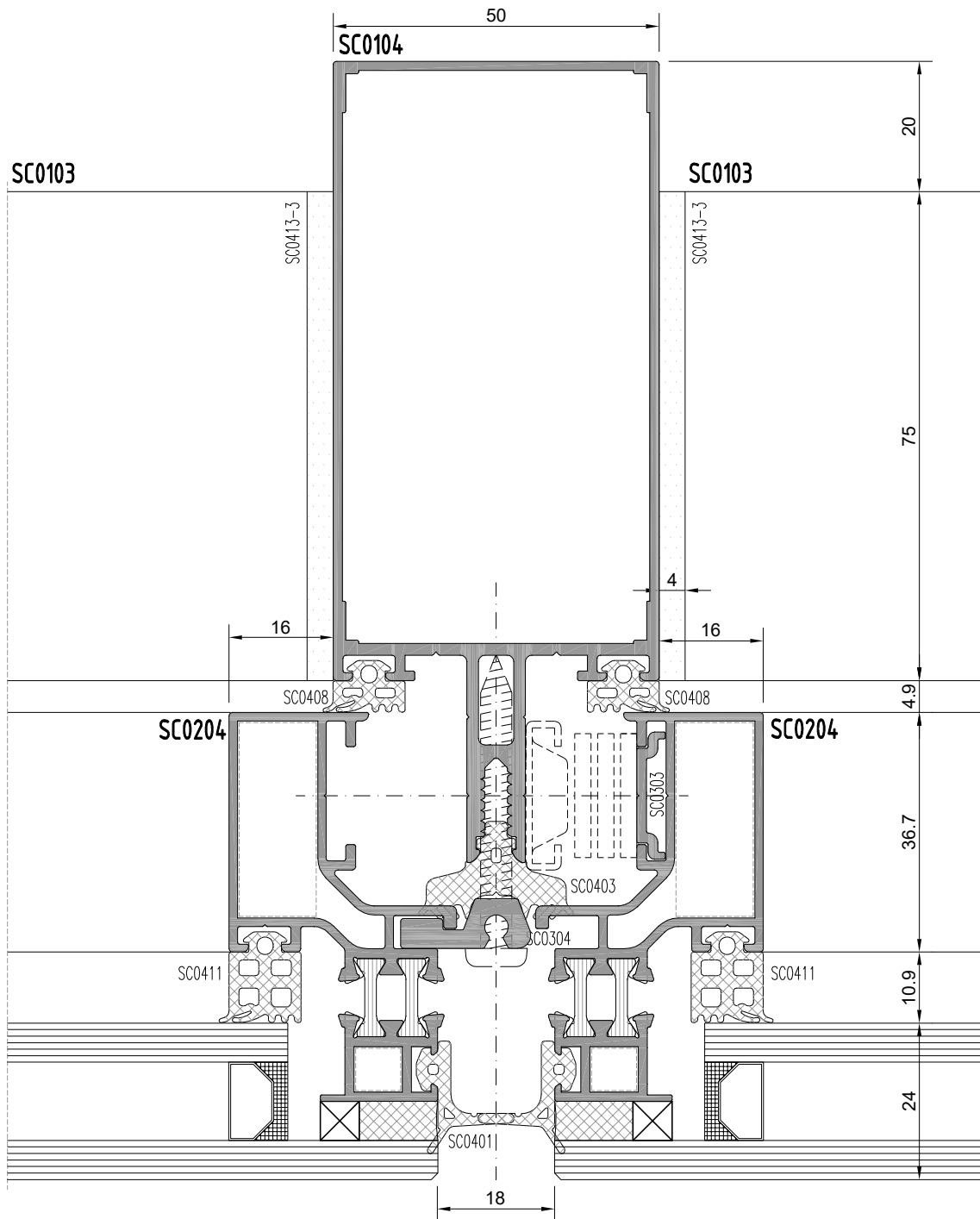
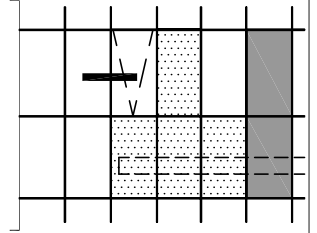

F50 KLASİK SİSTEM
SİLİKON CEPHE
F50 CLASSIC SYSTEM
SILICONE FACADE

SPANDREL - SABİT
SPANDREL-FIXED

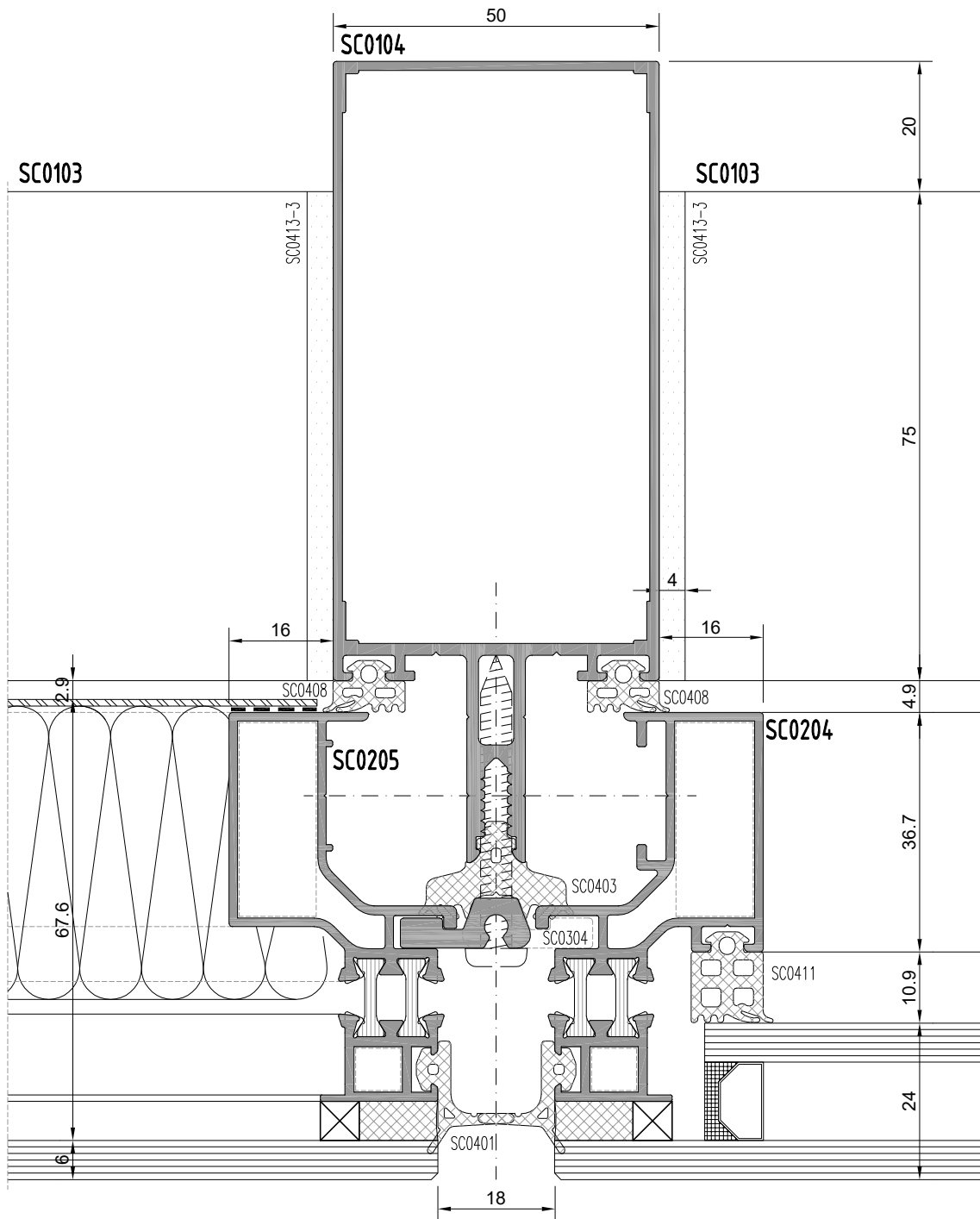
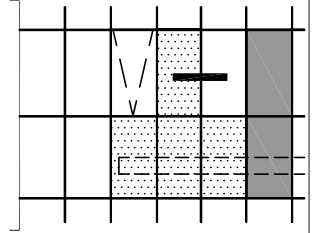

F50 KLASİK SİSTEM
SİLİKON CEPHE
F50 CLASSIC SYSTEM
SILICONE FACADE

SABİT - KOMPOZİT
FIXED-COMPOSITE

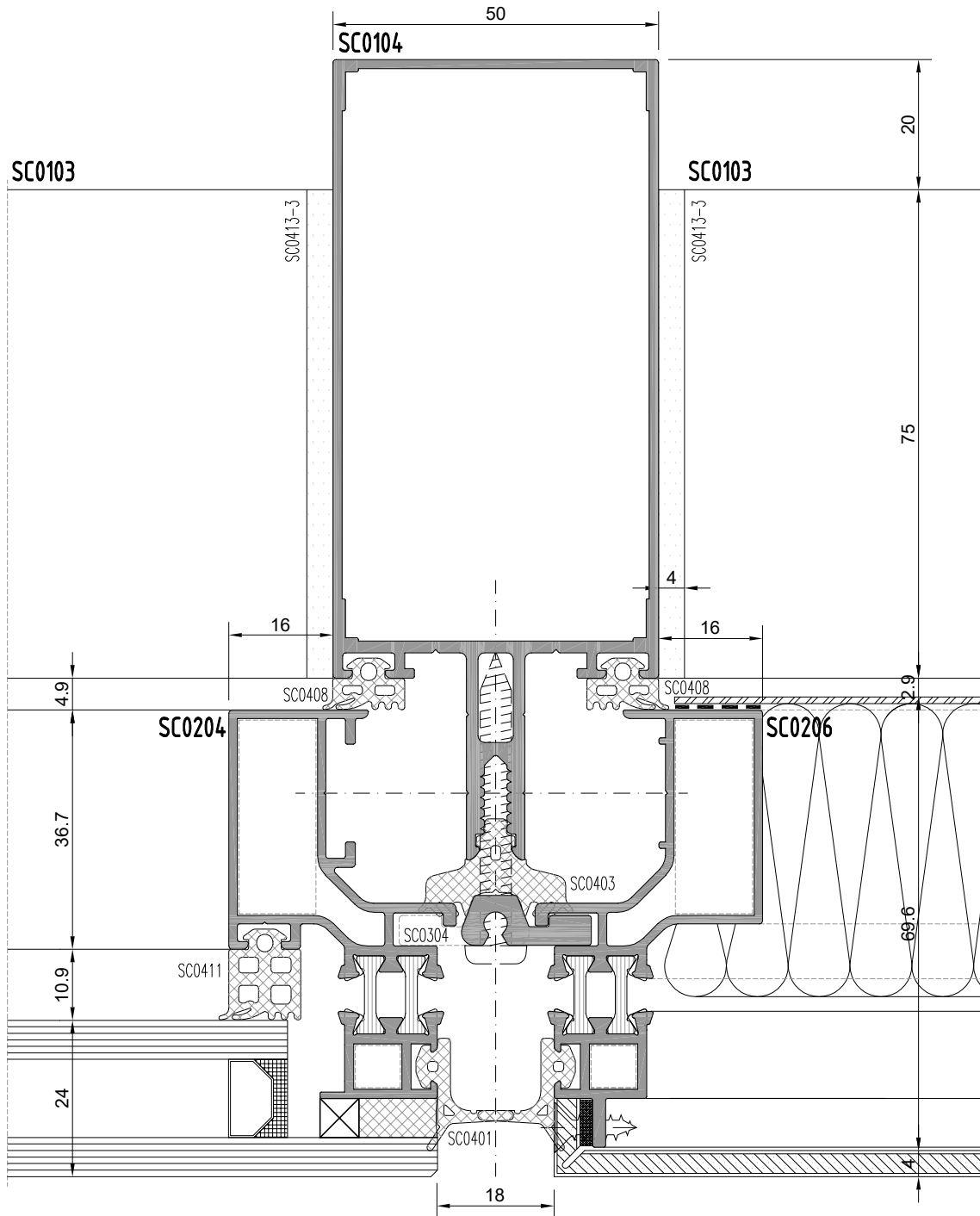
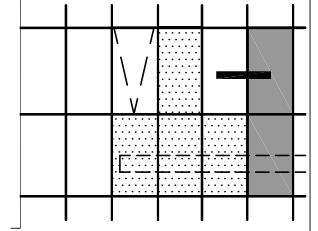

F50 KLASİK SİSTEM
SİLİKON CEPHE
F50 CLASSIC SYSTEM
SILICONE FACADE

SABİT - SABİT
FIXED-FIXED

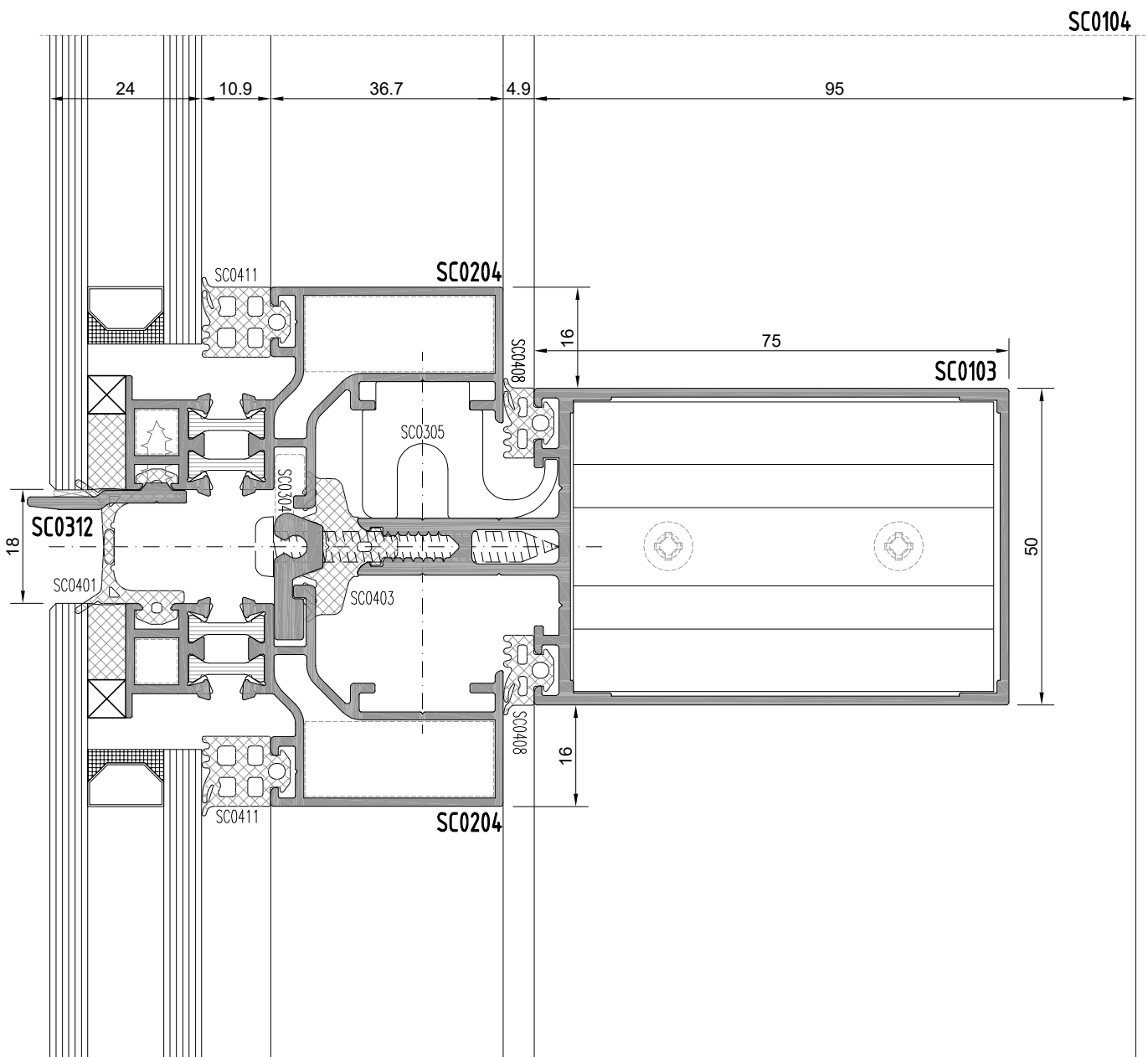
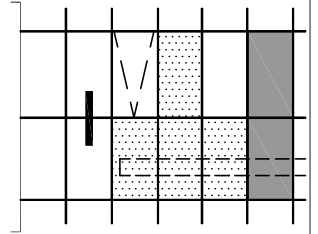

F50 KLASİK SİSTEM
SİLİKON CEPHE
F50 CLASSIC SYSTEM
SILICONE FACADE

KANAT - SPANDREL
SASH-SPANDREL

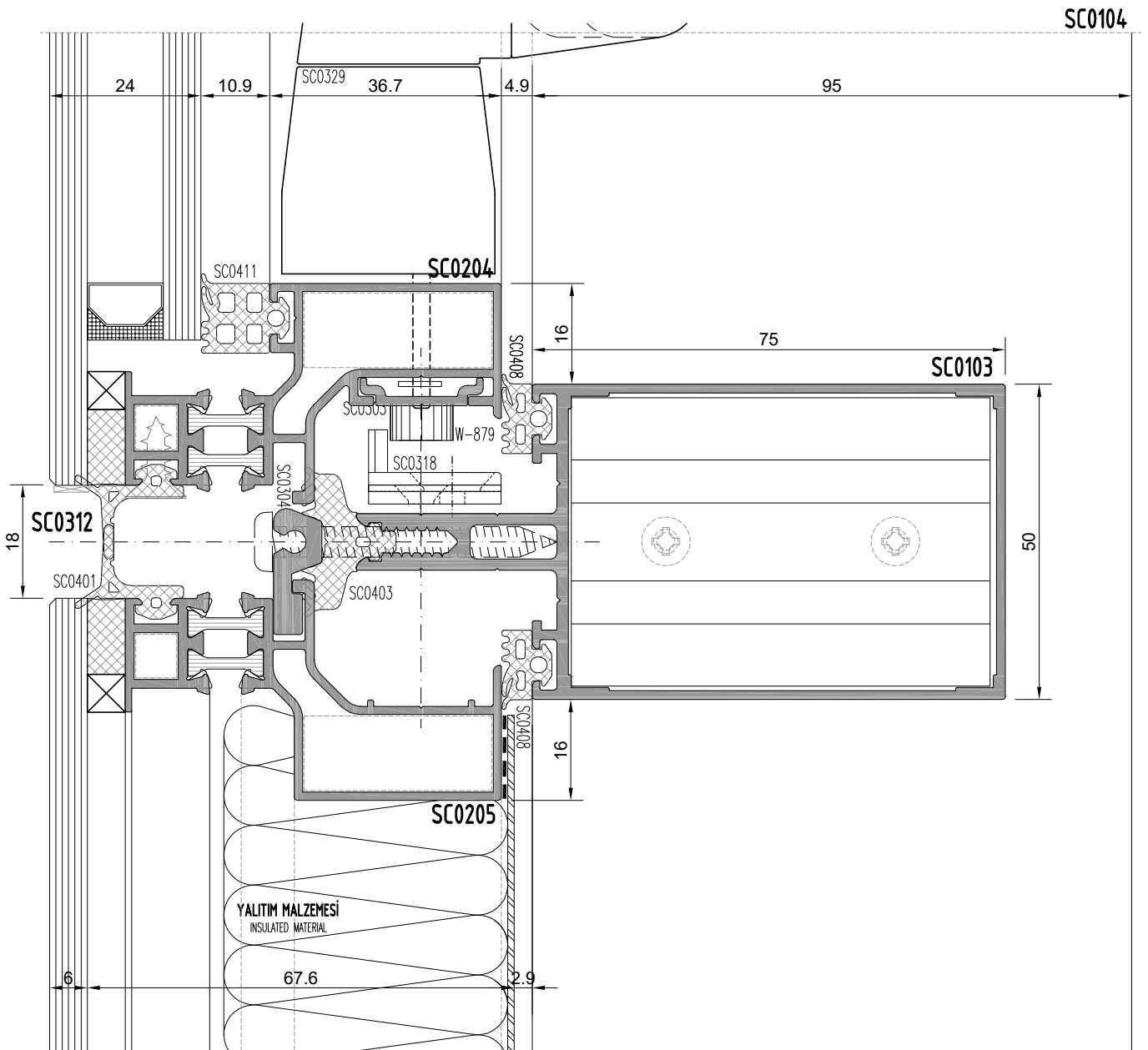
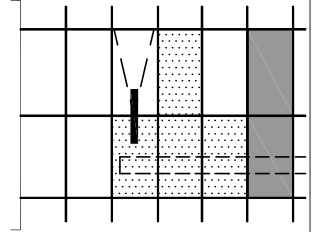

F50 KLASİK SİSTEM
SİLİKON CEPHE
F50 CLASSIC SYSTEM
SILICONE FACADE

SABİT - SPANDREL
FIXED-SPANDREL

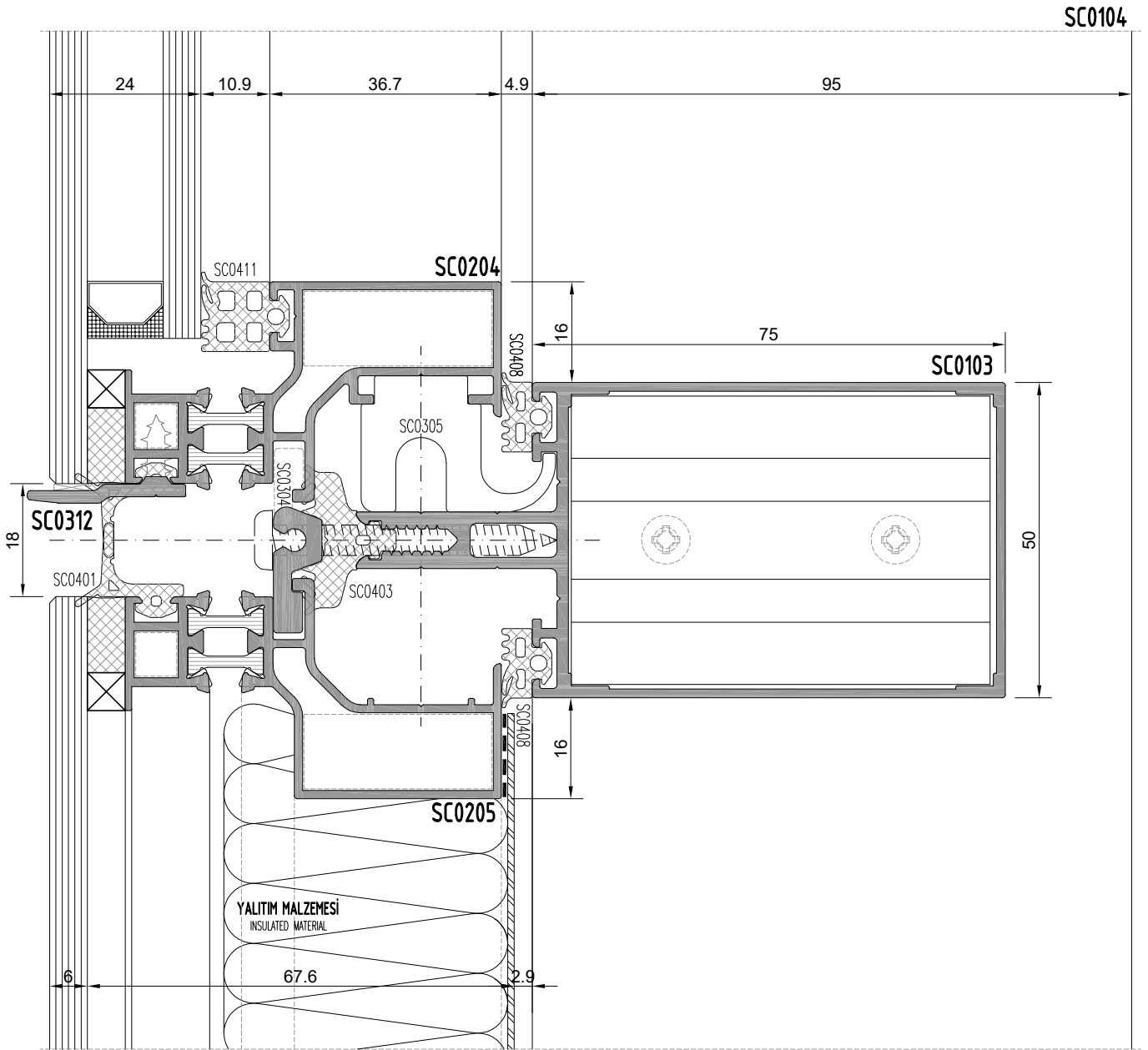
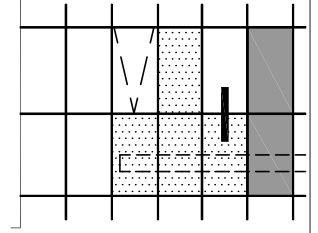

F50 KLASİK SİSTEM
SİLİKON CEPHE
F50 CLASSIC SYSTEM
SILICONE FACADE

SABİT - SABİT
FIXED-FIXED

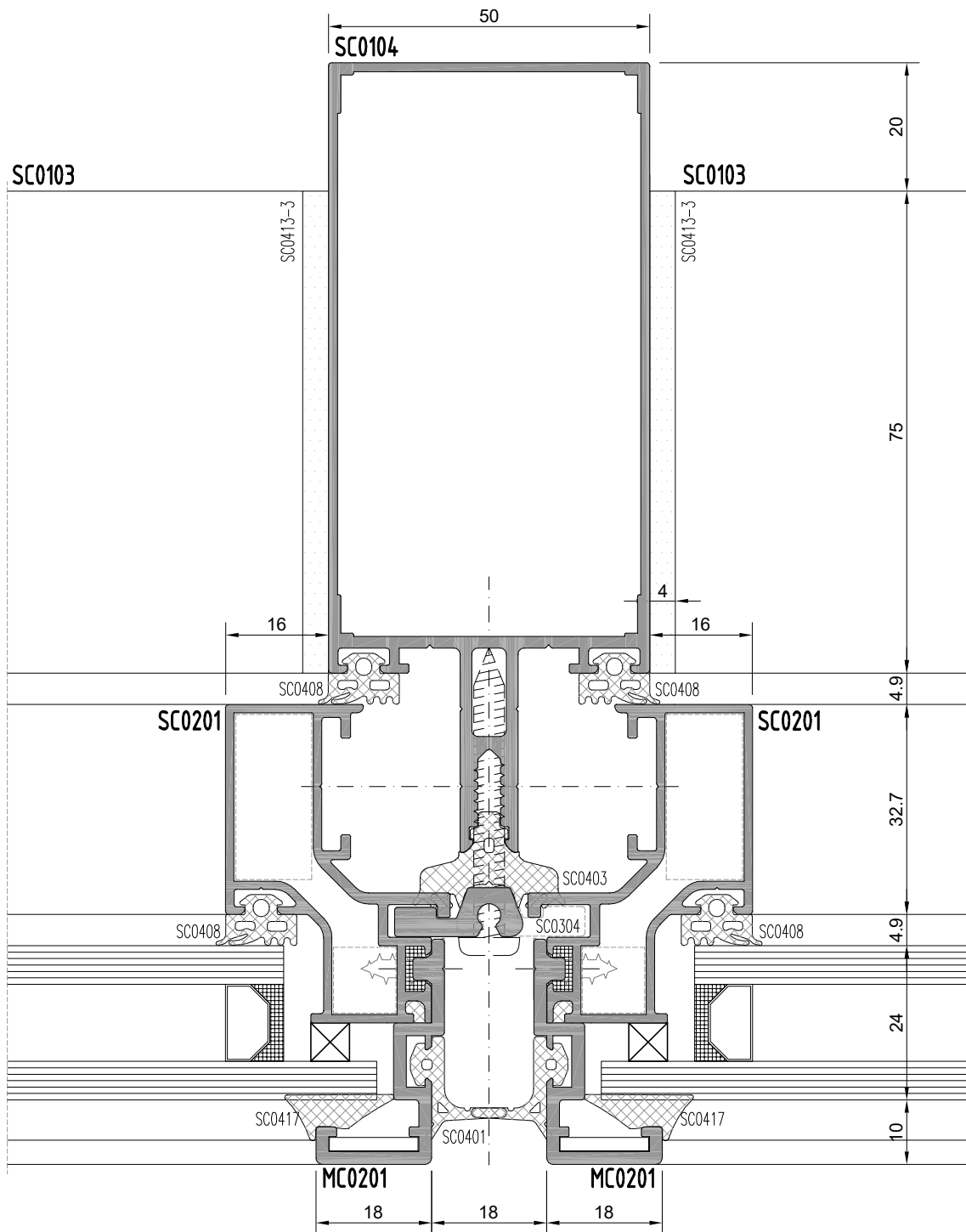
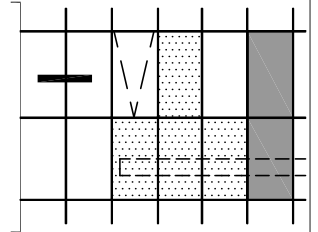

F50 KLASİK SİSTEM
SİLİKON CEPHE
F50 CLASSIC SYSTEM
SILICONE FACADE

SABİT - KANAT
FIXED-SASH

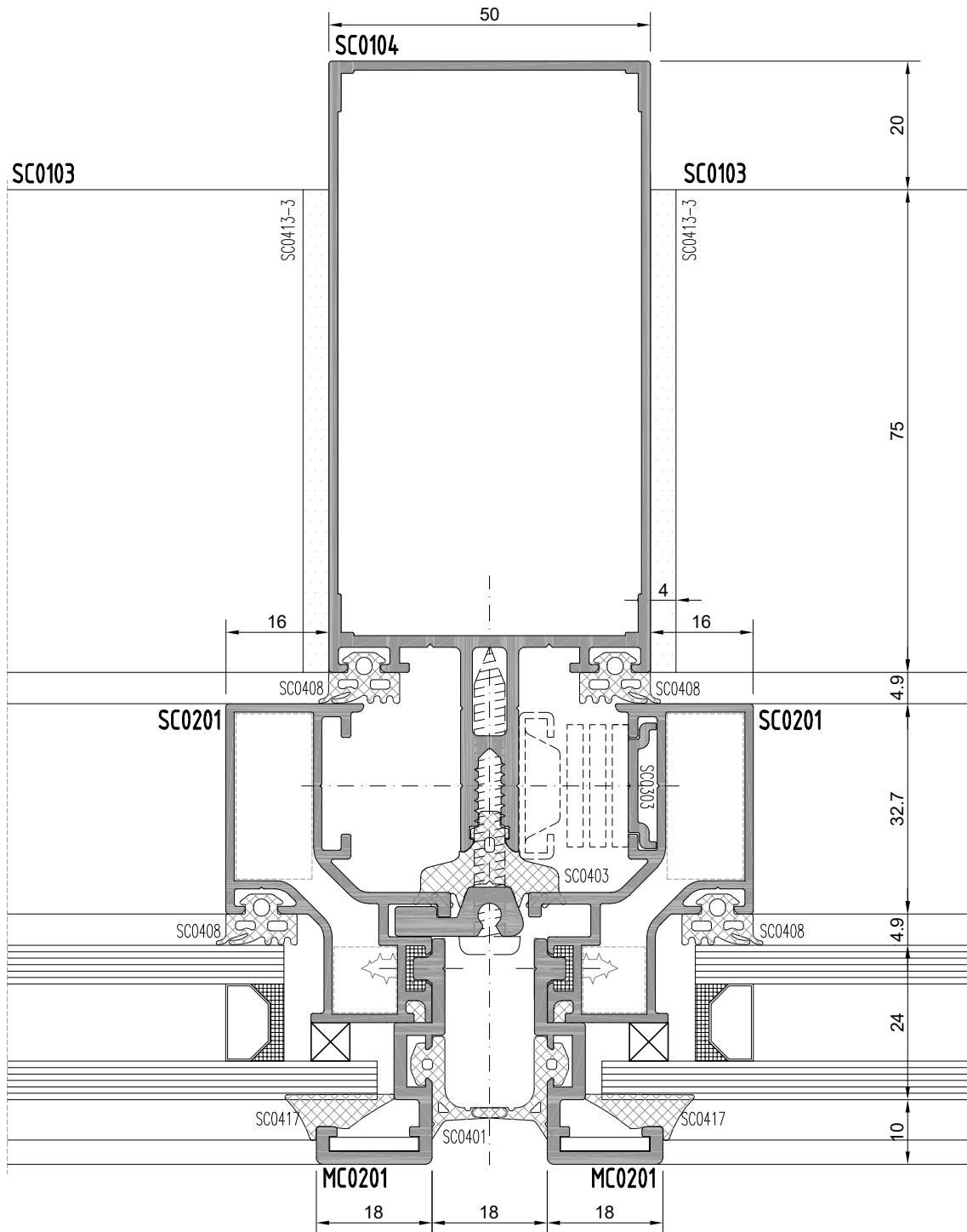
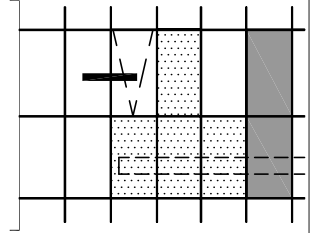

F50 KLASİK SİSTEM
SİLİKON CEPHE
F50 CLASSIC SYSTEM
SILICONE FACADE

KANAT - SPANDREL
SASH-SPANDREL

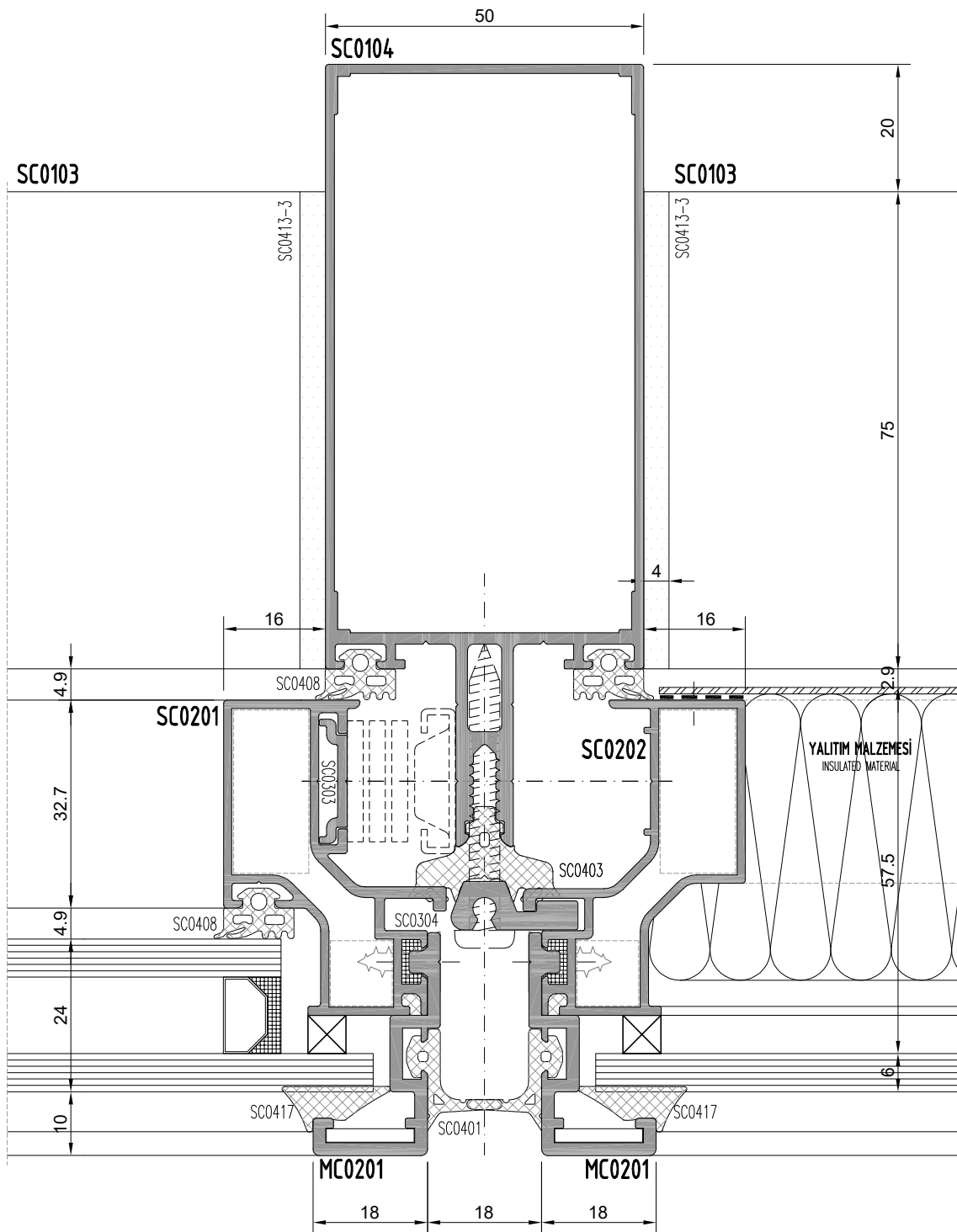
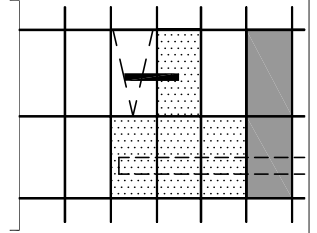

F50 KLASİK SİSTEM
SİLİKON CEPHE
F50 CLASSIC SYSTEM
SILICONE FACADE

SABİT - KOMPOZİT
FIXED-COMPOSITE

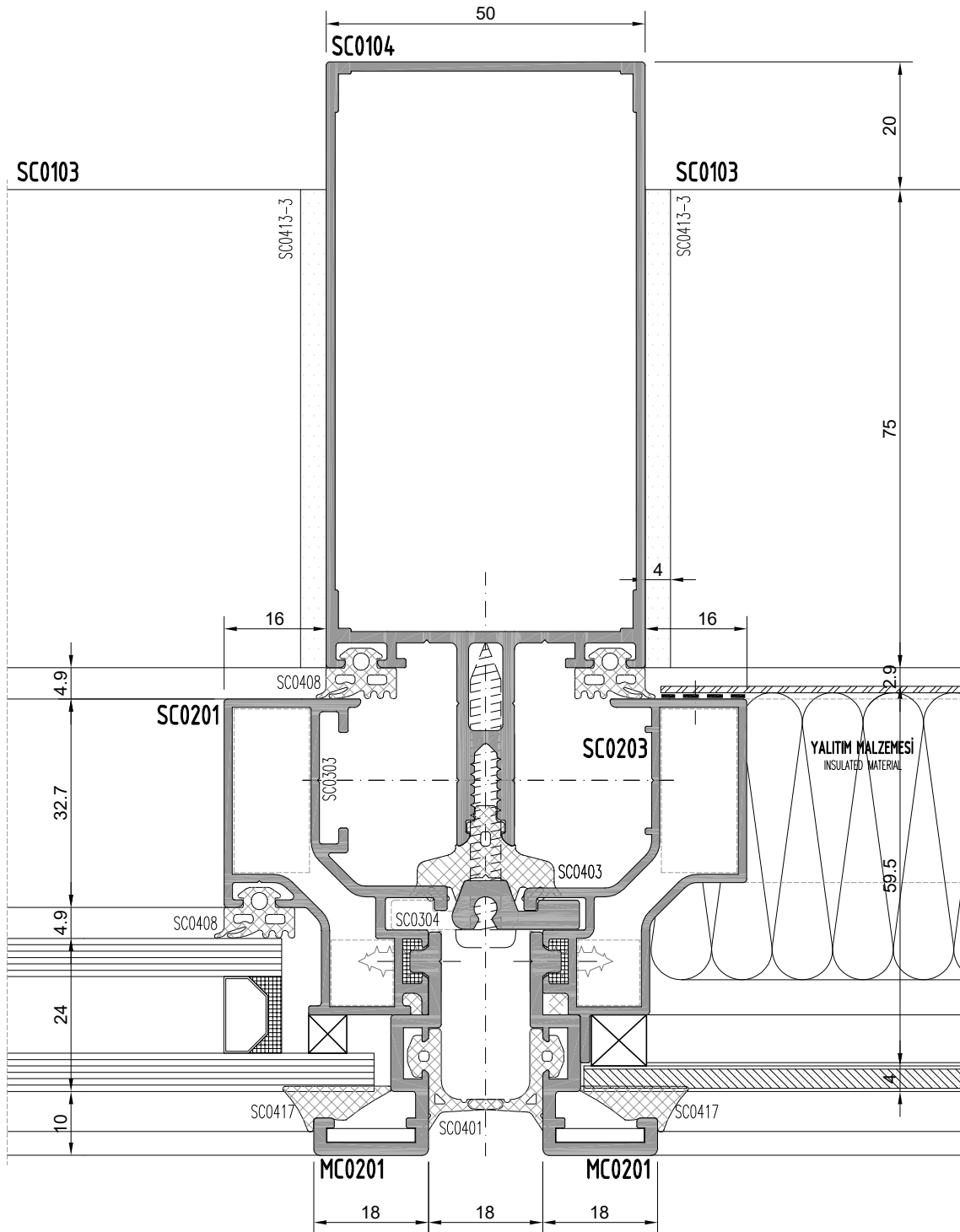
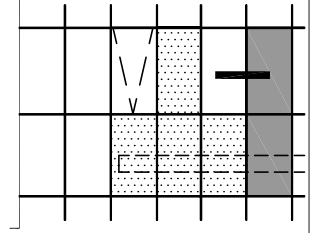

F50 KLASİK SİSTEM
SİLİKON CEPHE
F50 CLASSIC SYSTEM
SILICONE FACADE

SABİT - SABİT
FIXED-FIXED

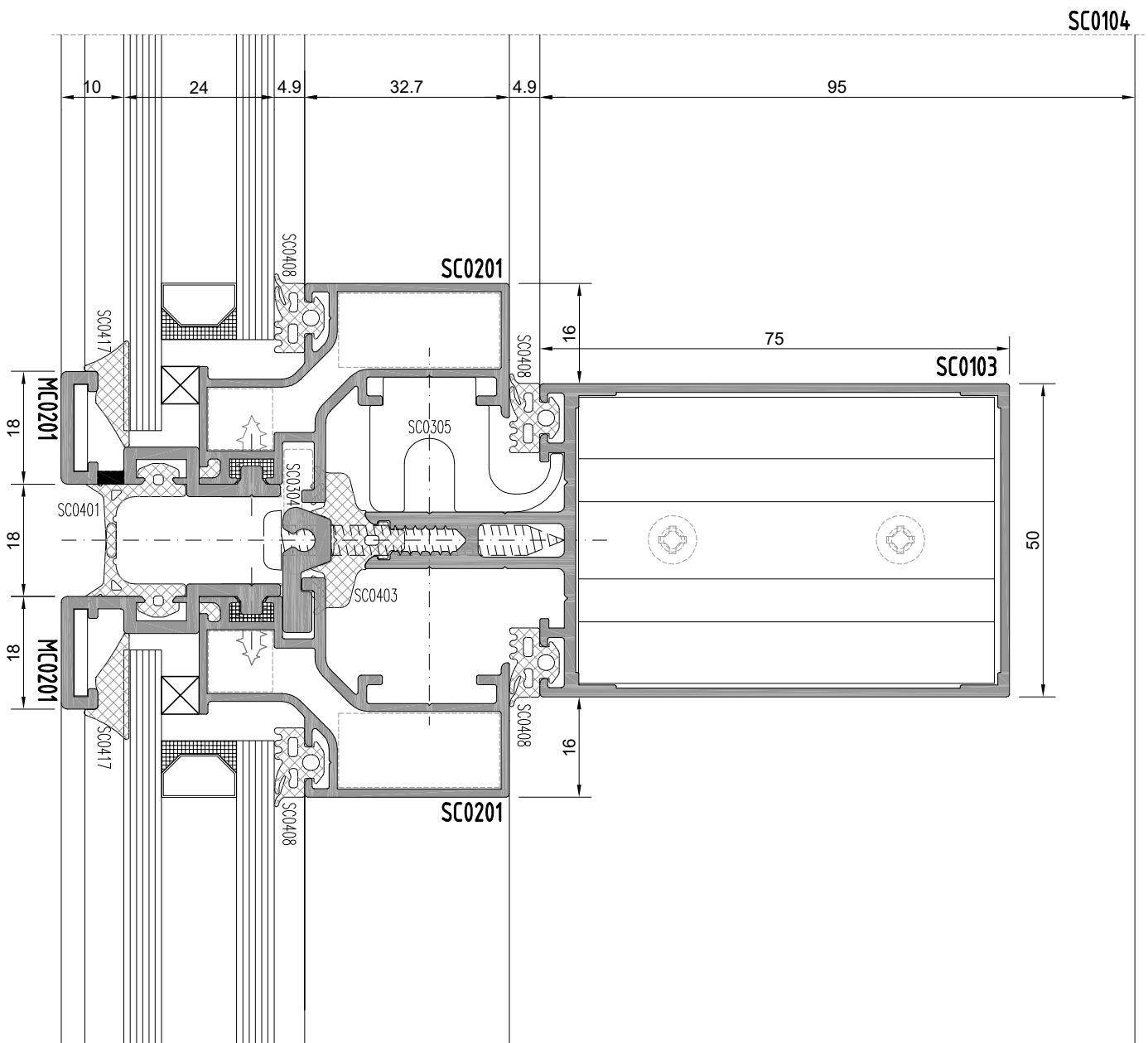
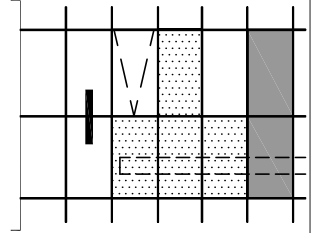

F50 KLASİK SİSTEM
SİLİKON CEPHE
F50 CLASSIC SYSTEM
SILICONE FACADE

SABİT - SABİT
FIXED-FIXED

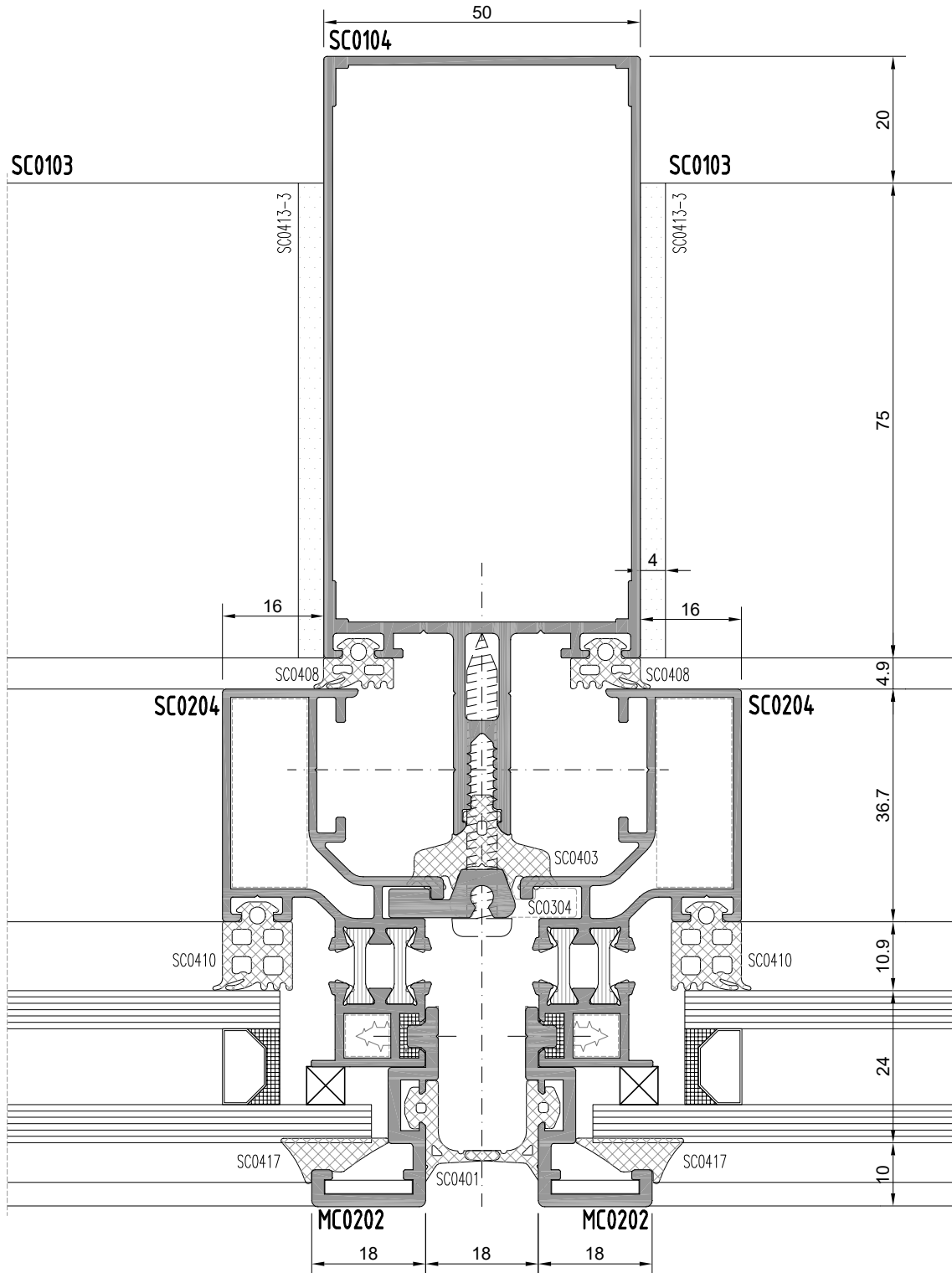
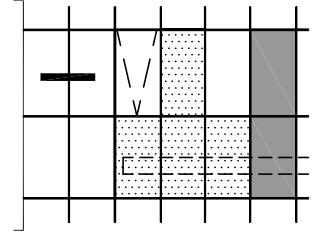

F50 KLASİK SİSTEM
SİLİKON CEPHE
F50 CLASSIC SYSTEM
SILICONE FACADE

SABİT - KANAT
FIXED-SASH

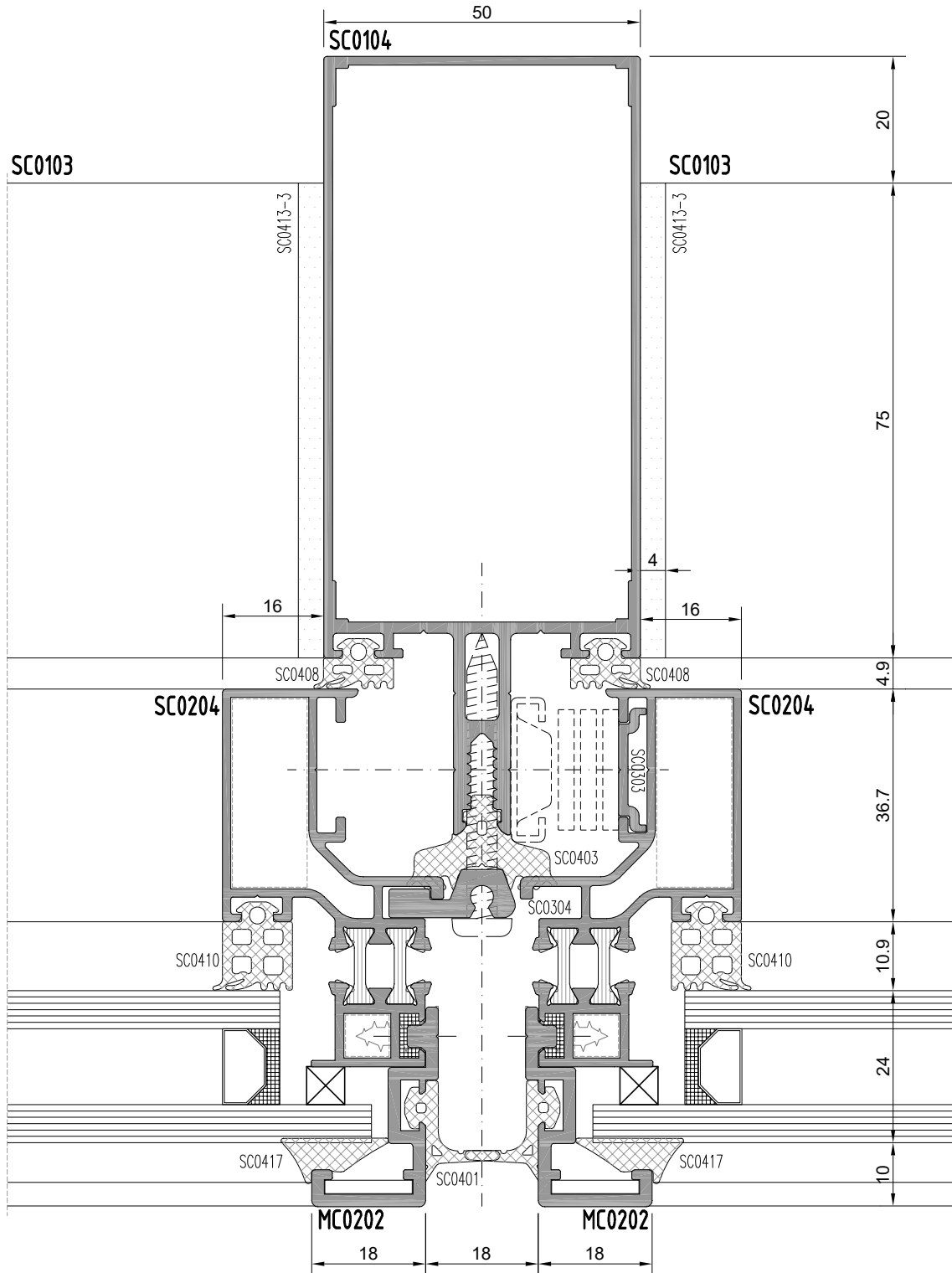
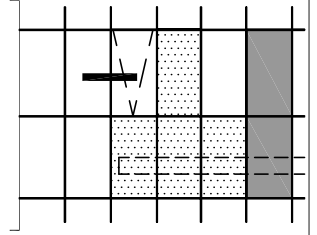

F50 KLASİK SİSTEM
SİLİKON CEPHE
F50 CLASSIC SYSTEM
SILICONE FACADE

KANAT - SPANDREL
SASH-SPANDREL

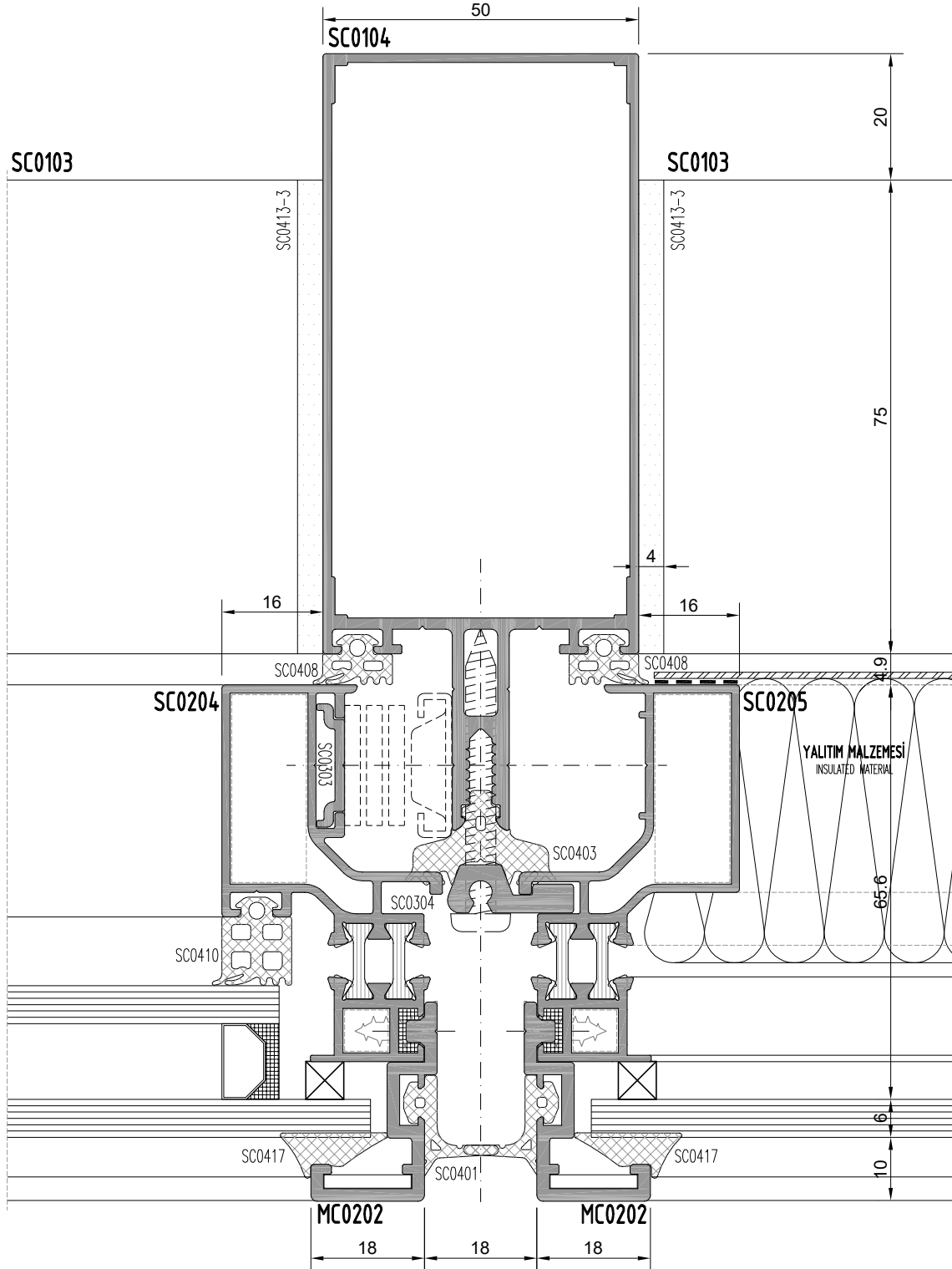
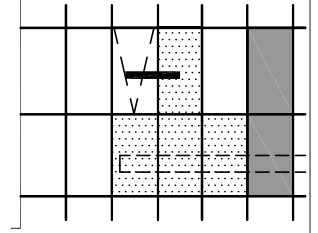

F50 KLASİK SİSTEM
SİLİKON CEPHE
F50 CLASSIC SYSTEM
SILICONE FACADE

SABİT - SABİT
FIXED-FIXED

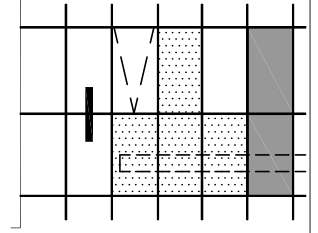

SC0104

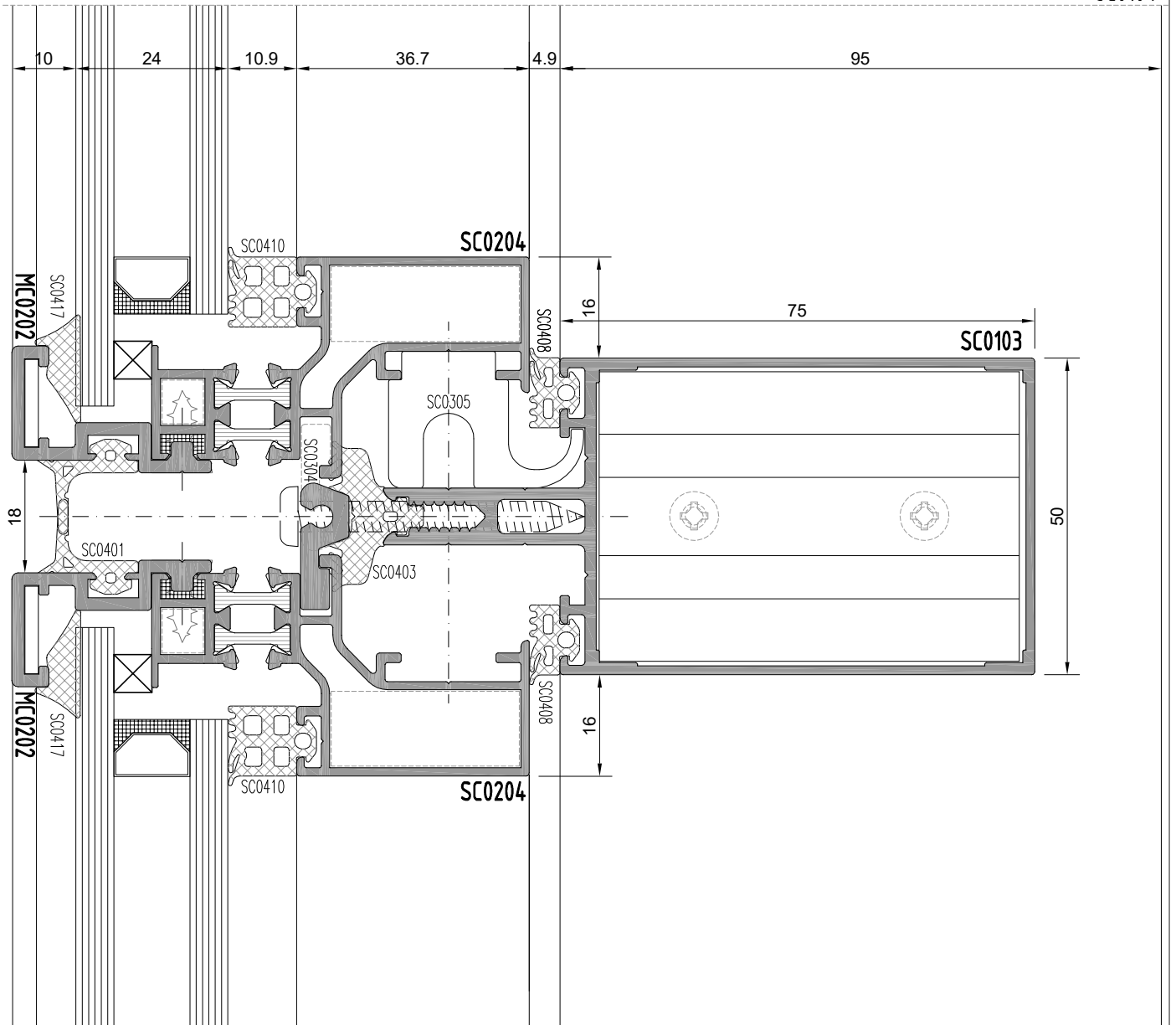

F50 KLASİK SİSTEM
SİLİKON CEPHE
F50 CLASSIC SYSTEM
SILICONE FACADE

SPANDREL - SPANDREL
SPANDREL-SPANDREL

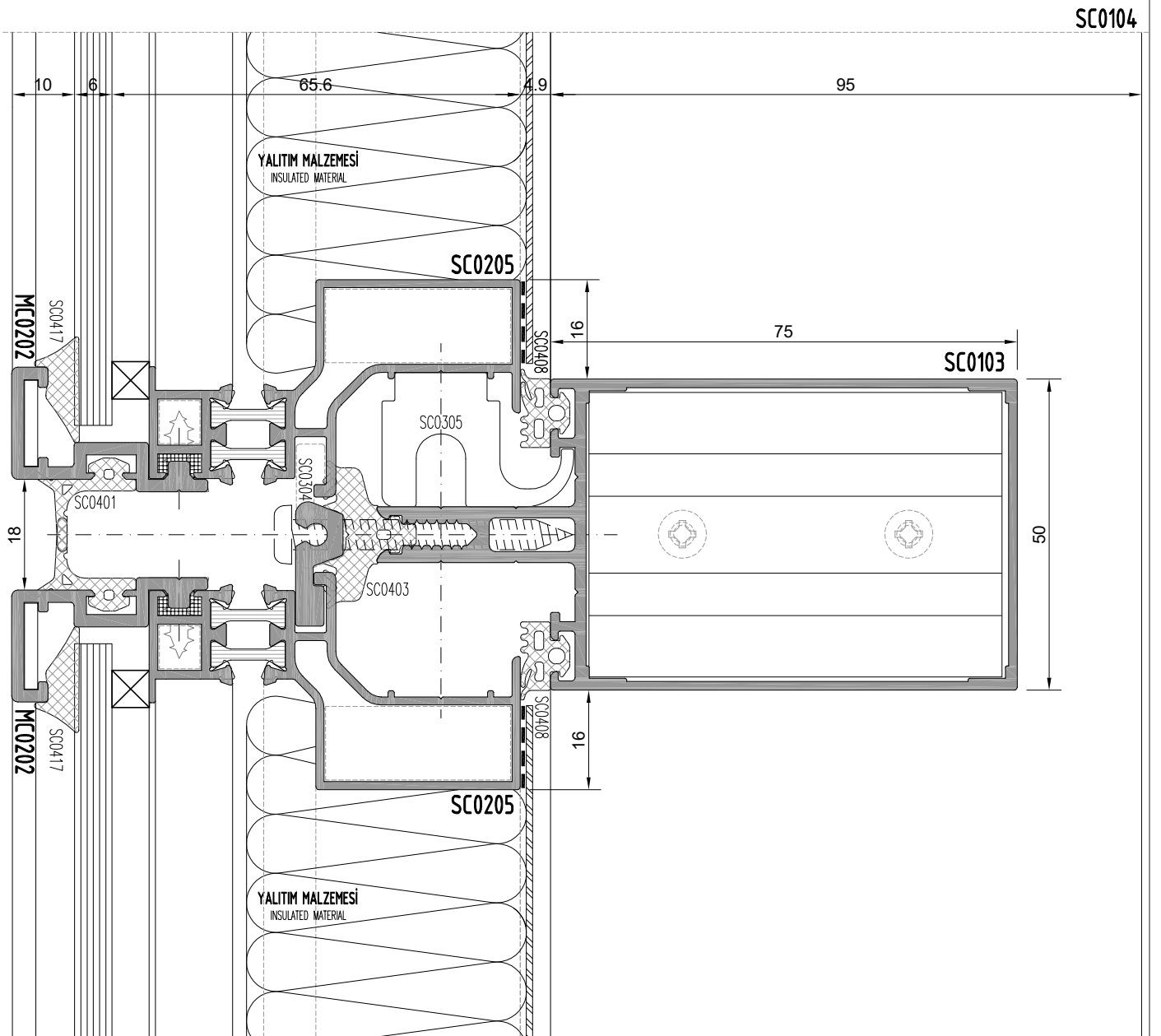
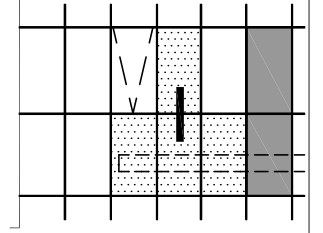

F50 KLASİK SİSTEM
SİLİKON CEPHE
F50 CLASSIC SYSTEM
SILICONE FACADE

KOMPOZİT - KOMPOZİT
COMPOSITE-COMPOSITE

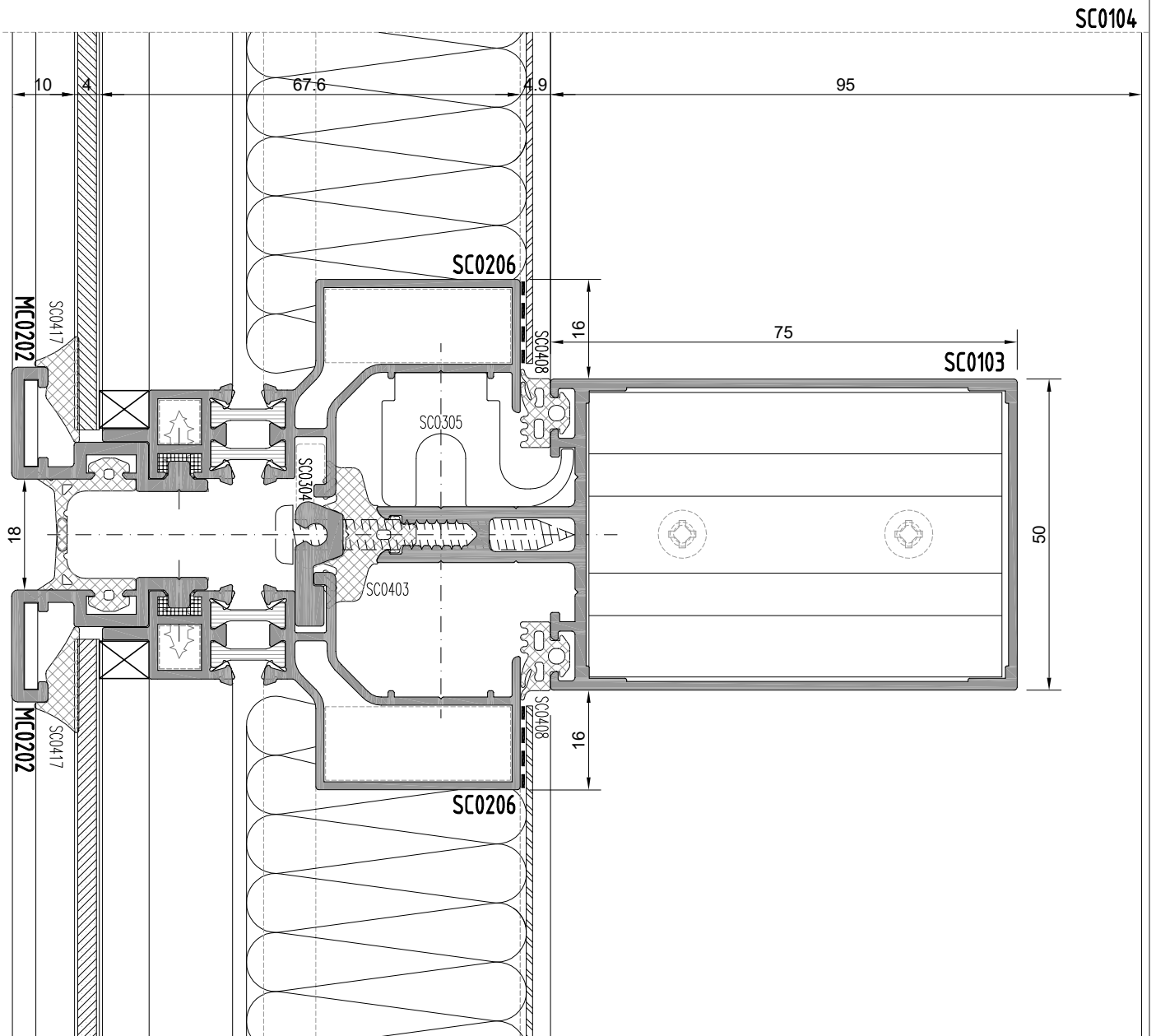
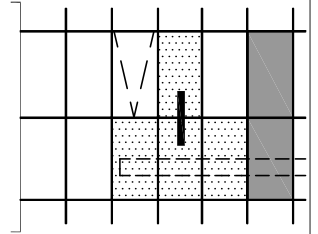

F50 KLASİK SİSTEM
SİLİKON CEPHE
F50 CLASSIC SYSTEM
SILICONE FACADE

SABİT - KANAT
FIXED-SASH

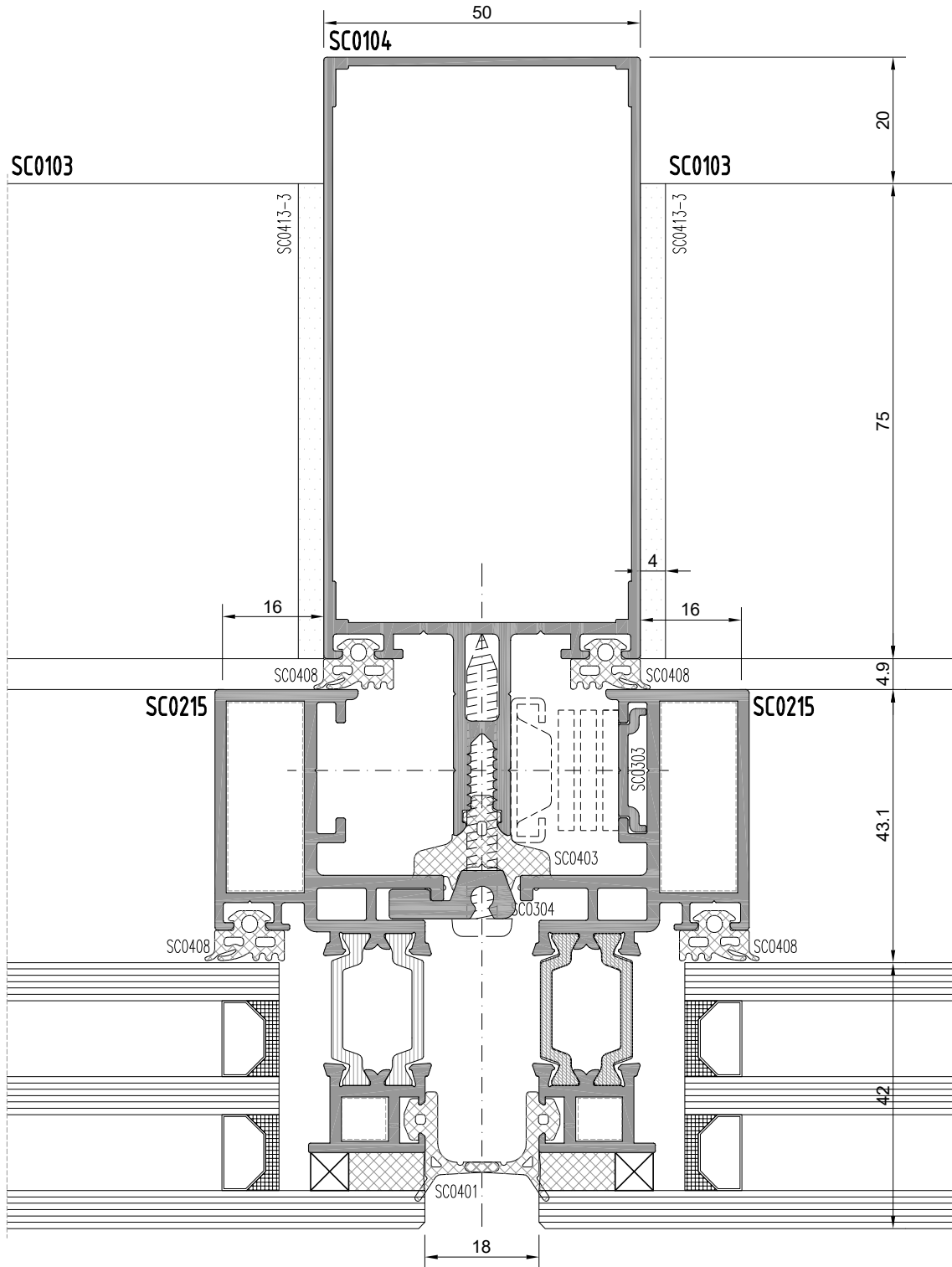
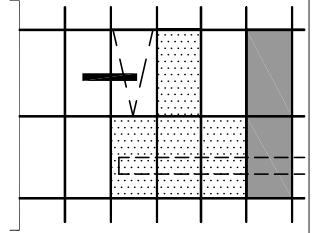

F50 KLASİK SİSTEM
SİLİKON CEPHE
F50 CLASSIC SYSTEM
SILICONE FACADE

SABİT - SABİT
FIXED-FIXED

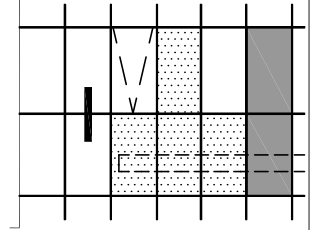

SC0104

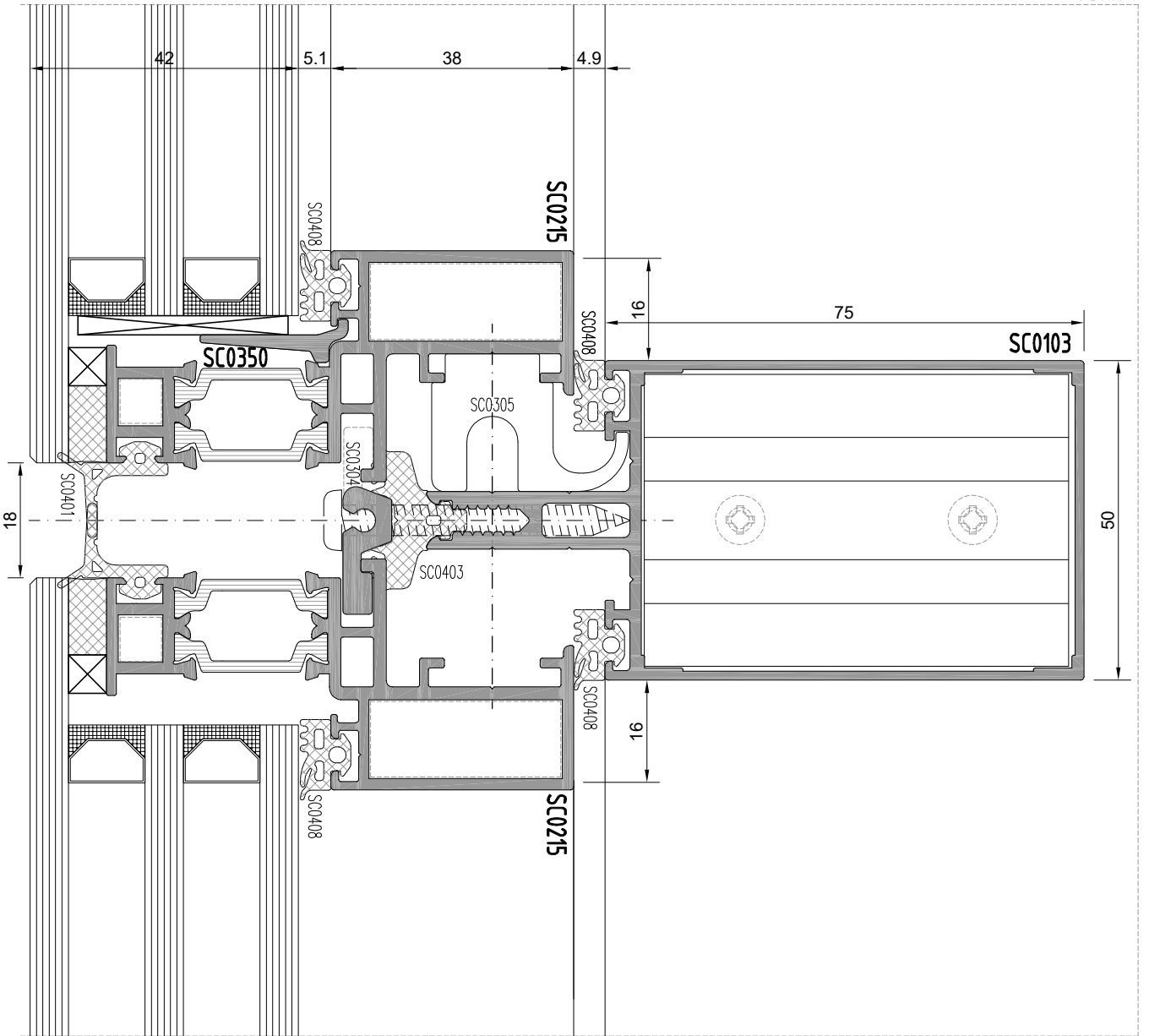





F50 KLASİK SİSTEM

SİLİKON CEPHE

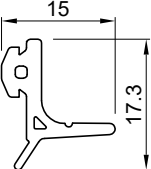
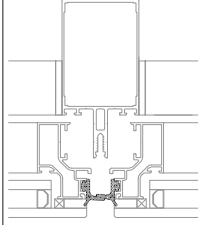
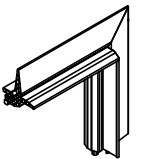
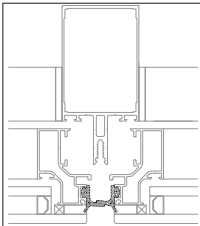
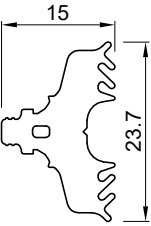
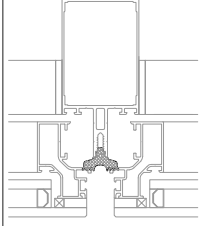
F50 CLASSIG SYSTEM
SILICONE FACADE

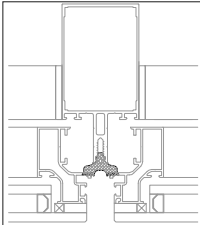
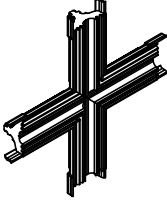
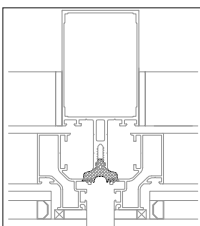
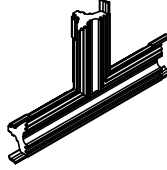
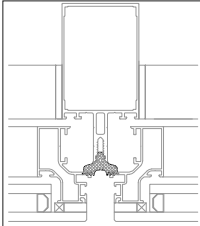
Fitil listesi
Gasket list

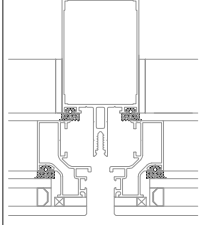

kod code	şekil drawing	tanım description	teorik ağırlık teoretical weight gr / m	paket ağırlığı package weight kg / package	paket metrajı in one package metre / package	kullanım yeri aplication
SC0401		Panel dış fitili Frame gasket	74 gr/m	15 kg	202 m	
SC0402		Panel dış fitili (köşe) Frame gasket (corner)	89 gr/m	-	50 ad-pcs	
SC0403		Taşıyıcı ön fitili Mullion or transom front gasket	173 gr/m	15 kg	87 m	
SC0404		Taşıyıcı ön fitili (L merkez) Mullion or transom front gasket (L center)	17,6 gr/ad	-	50 ad-pcs	
SC0405		Taşıyıcı ön fitili (T merkez) Mullion or transom front gasket (T center)	31,6 gr/ad	-	50 ad-pcs	
SC0406		Taşıyıcı ön fitili (+ merkez) Mullion or transom front gasket (+ center)	24,6 gr/ad	-	50 ad-pcs	
SC0422		Taşıyıcı ve Panel iç fitili Mullion-transom or Panel gasket inside	46 gr/m	15 kg	326 m	

F50 KLASİK SİSTEM

SİLİKON CEPHE

F50 CLASSIC SYSTEM
SILICONE FAÇADE

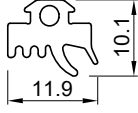
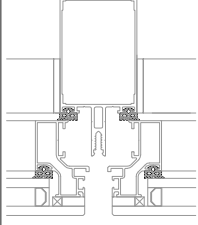
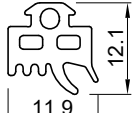
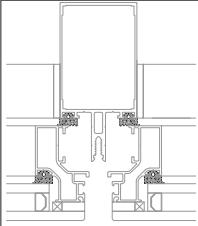
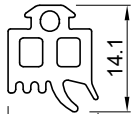
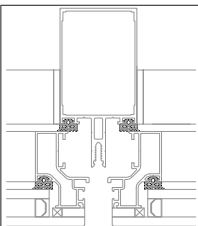
Fıtıl listesi
Gasket list

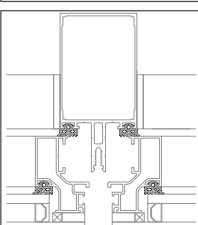
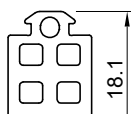
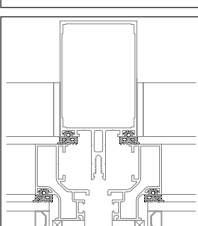
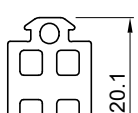
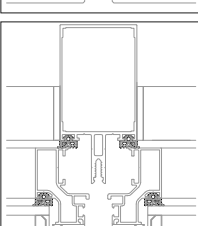
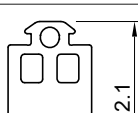
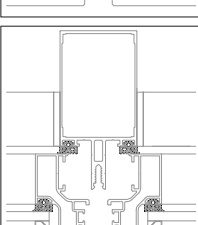
kod code	şekil drawing	tanım description	teorik ağırlık theoretical weight gr / m	paket ağırlığı package weight kg / package	paket metraji in one package metre / package	kullanım yeri aplication
SC0407		Taşıyıcı ve Panel iç fıtılı Mullion-transom or Panel gasket inside	73 gr/m	15 kg	205 m	
SC0408		Taşıyıcı ve Panel iç fıtılı Mullion-transom or Panel gasket inside	88 gr/m	15 kg	170 m	
SC0409		Taşıyıcı ve Panel iç fıtılı Mullion-transom or Panel gasket inside	101 gr/m	15 kg	148 m	
SC0410		Taşıyıcı ve Panel iç fıtılı Mullion-transom or Panel gasket inside	113 gr/m	15 kg	133 m	
SC0411		Taşıyıcı ve Panel iç fıtılı Mullion-transom or Panel gasket inside	144 gr/m	15 kg	104 m	
SC0420		Taşıyıcı ve Panel iç fıtılı Mullion-transom or Panel gasket inside	167 gr/m	15 kg	90 m	
SC0421		Taşıyıcı ve Panel iç fıtılı Mullion-transom or Panel gasket inside	189 gr/m	15 kg	79 m	

F50 KLASİK SİSTEM

SİLİKON CEPHE

F50 CLASSIC SYSTEM
SILICONE FACADE

Fitil listesi
Gasket list

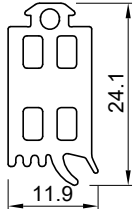
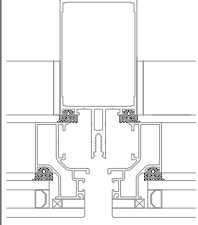
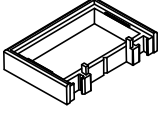
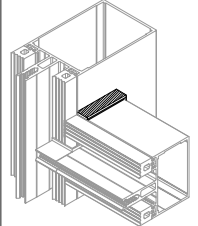
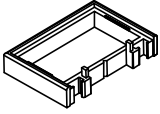
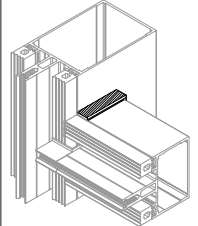
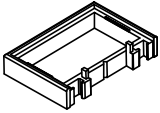
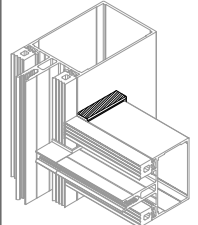
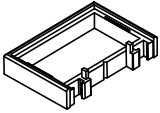
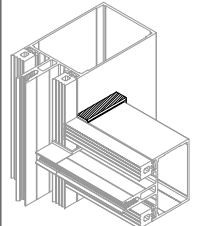
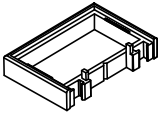
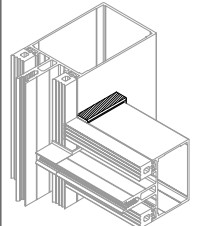
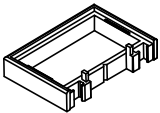
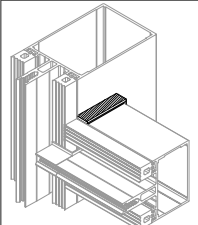
kod code	şekil drawing	tanım description	teorik ağırlık theoretical weight gr / m	paket ağırlığı package weight kg / package	paket metrajı in one package metre / package	kullanım yeri aplication
SC0425		Taşıyıcı ve Panel iç fitili Mullion-transom or Panel gasket inside	217,6 gr/m	15 kg	69 m	
SC0412-1		Kırlangıç geçme Yaka fitili (37 lik) T-connector Gasket for transom (SC0101-SC0110)	7 gr/ad	-	50 ad-pcs	
SC0412-2		Kırlangıç geçme Yaka fitili (57 lik) T-connector Gasket for transom (SC0102-SC0111)	9,2 gr/ad	-	50 ad-pcs	
SC0412-3		Kırlangıç geçme Yaka fitili (77 lik) T-connector Gasket for transom (SC0103-SC0112)	11 gr/ad	-	50 ad-pcs	
SC0412-4		Kırlangıç geçme Yaka fitili (97 lik) T-connector Gasket for transom (SC0104-SC0113)	13 gr/ad	-	50 ad-pcs	
SC0412-5		Kırlangıç geçme Yaka fitili (117 lik) T-connector Gasket for transom (SC0105-SC0114)	13 gr/ad	-	50 ad-pcs	
SC0412-6		Kırlangıç geçme Yaka fitili (137 lik) T-connector Gasket for transom (SC0106-SC0115)	17 gr/ad	-	50 ad-pcs	

F50 KLASİK SİSTEM

SİLİKON CEPHE

F50 CLASSIG SYSTEM
SILICONE FACADE

Fitil listesi
Gasket list

kod code	şekil drawing	tanım description	teorik ağırlık theoretical weight gr / m	paket ağırlığı package weight kg / package	paket metrajı in one package metre / package	kullanım yeri aplication
SC0412-7		Kırlangıç geçme Yaka fitili (157 lik) T-connector Gasket for transom (SC0107-SC0116)	9,2 gr/ad	-	50 ad-pcs	
SC0412-8		Kırlangıç geçme Yaka fitili (177 lik) T-connector Gasket for transom (SC0108-SC0117)	21 gr/ad	-	50 ad-pcs	
SC0413-1		Klasik bağlantı Yaka fitili (35 lik) T-connector Gasket for transom (SC0101-SC0110)	-	-	50 ad-pcs	
SC0413-2		Klasik bağlantı Yaka fitili (55 lik) T-connector Gasket for transom (SC0102-SC0111)	-	-	50 ad-pcs	
SC0413-3		Klasik bağlantı Yaka fitili (75 lik) T-connector Gasket for transom (SC0103-SC0112)	-	-	50 ad-pcs	
SC0413-4		Klasik bağlantı Yaka fitili (95 lik) T-connector Gasket for transom (SC0104-SC0113)	-	-	50 ad-pcs	
SC0413-5		Klasik bağlantı Yaka fitili (115 lik) T-connector Gasket for transom (SC0105-SC0114)	-	-	50 ad-pcs	

F50 KLASİK SİSTEM
SİLİKON CEPHE
F50 CLASSIG SYSTEM
SILICONE FACADE

Fitil listesi
Gasket list

kod code	şekil drawing	tanım description	teorik ağırlık theoretical weight gr / m	paket ağırlığı package weight kg / package	paket metrajı in one package metre / package	kullanım yeri aplication
SC0413-6		Klasik bağlantı Yaka fitili (135 lik) T-connector Gasket for transom (SC0106-SC0115)	-	-	50 ad-pcs	
SC0413-7		Klasik bağlantı Yaka fitili (155 lik) T-connector Gasket for transom (SC0107-SC0116)	-	-	50 ad-pcs	
SC0413-8		Klasik bağlantı Yaka fitili (175 lik) T-connector Gasket for transom (SC0108-SC0117)	-	-	50 ad-pcs	
SC0417		Kalın kama fitili Frame gasket inside	96 gr/m	15 kg	156 m	
SC0423		Taşıyıcı ve Panel iç fitili Mullion-transom or Panel gasket inside	54 gr/m	15 kg	278 m	

F50 KLASİK SİSTEM
SİLİKON CEPHE
F50 CLASSIC SYSTEM
SILICONE FACADE

İMALAT ŞEMASI
PRODUCTION PLAN

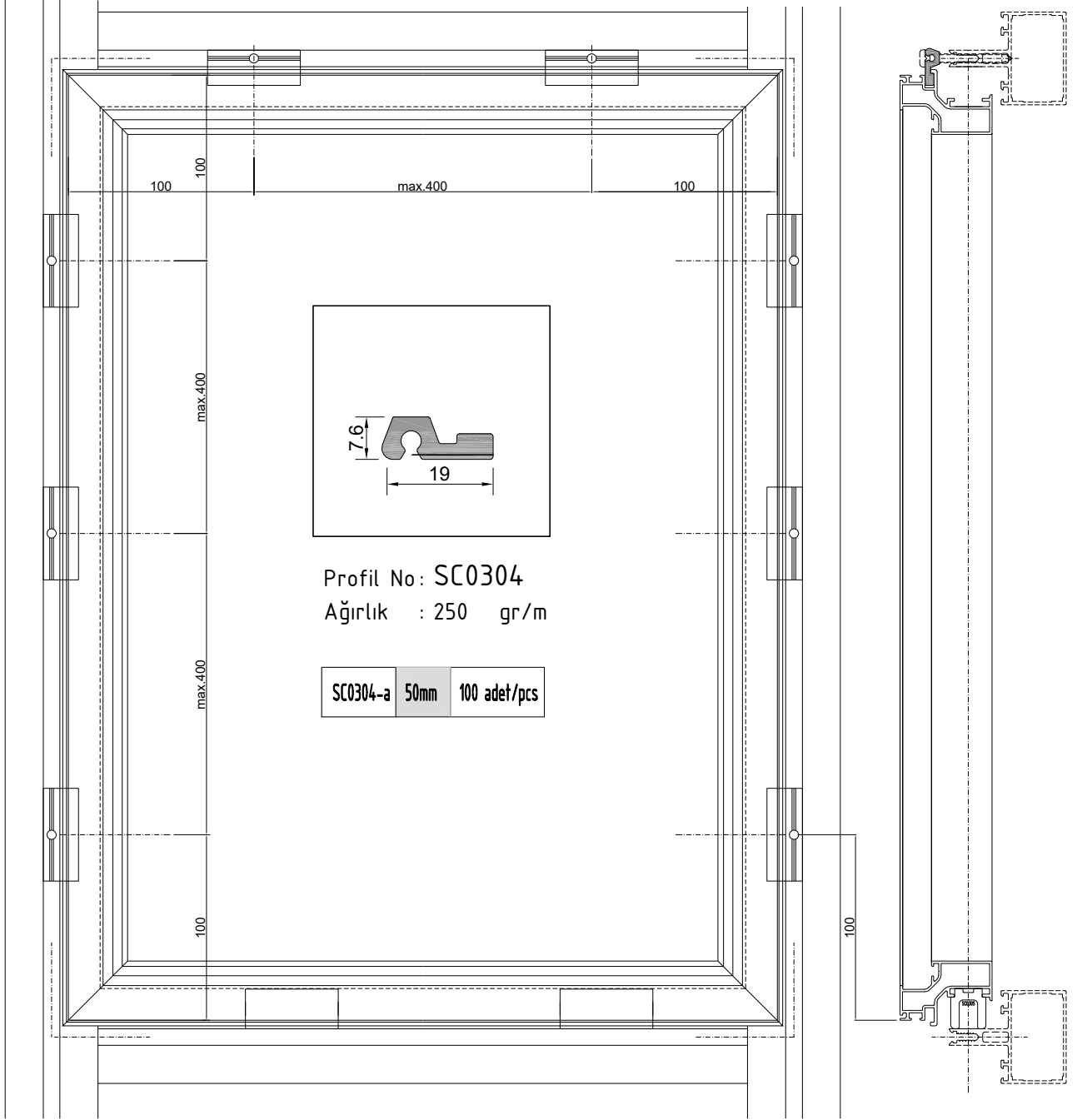

SC (T) Dıştan kilitleme sistemi
SC(T) Outside locking systems

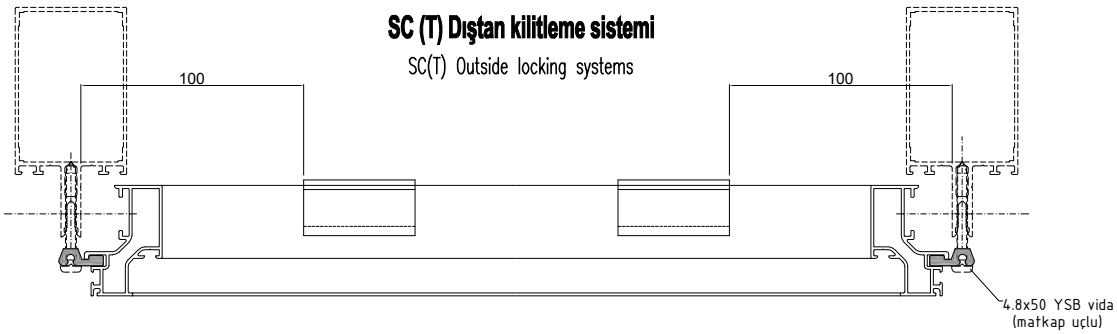

F50 KLASİK SİSTEM

SİLİKON CEPHE

F50 CLASSIC SYSTEM
SILICONE FACADE

İMALAT ŞEMASI
PRODUCTION PLAN

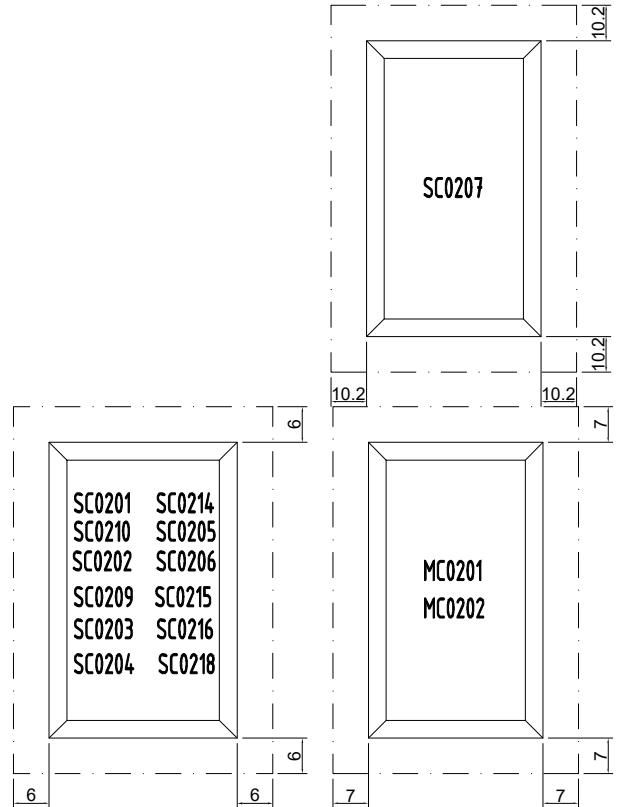
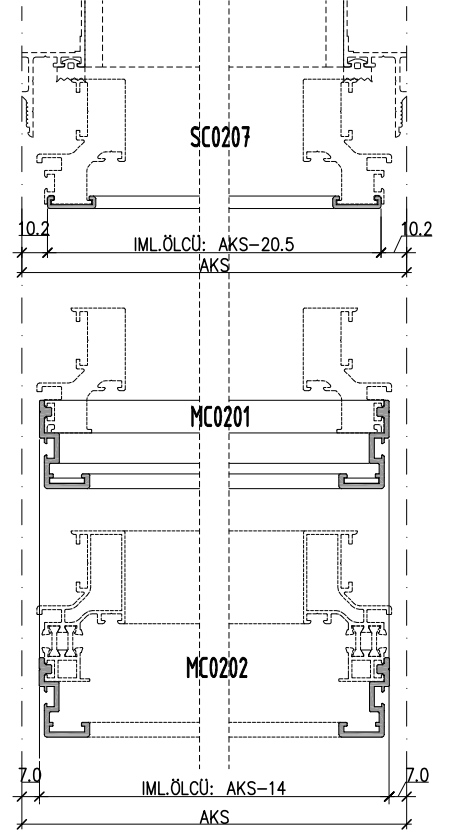
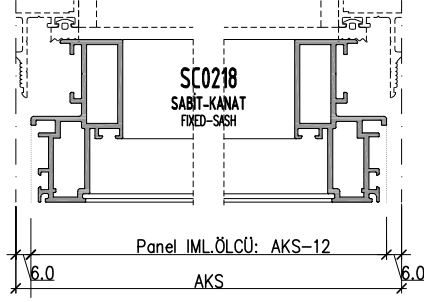
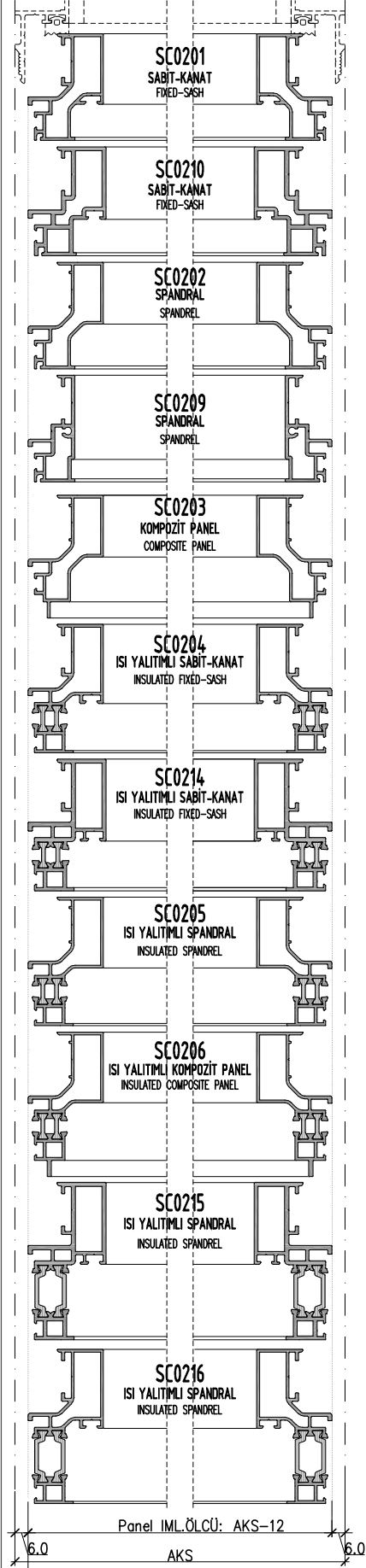

F50 KLASİK SİSTEM

SİLİKON CEPHE

F50 CLASSIC SYSTEM
SILICONE FACADE

İMALAT ŞEMASI
PRODUCTION PLAN

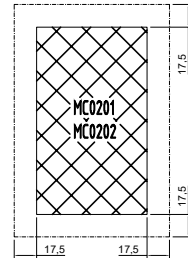
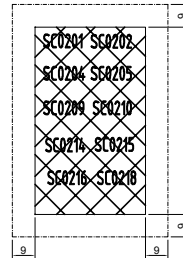
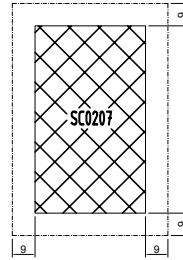
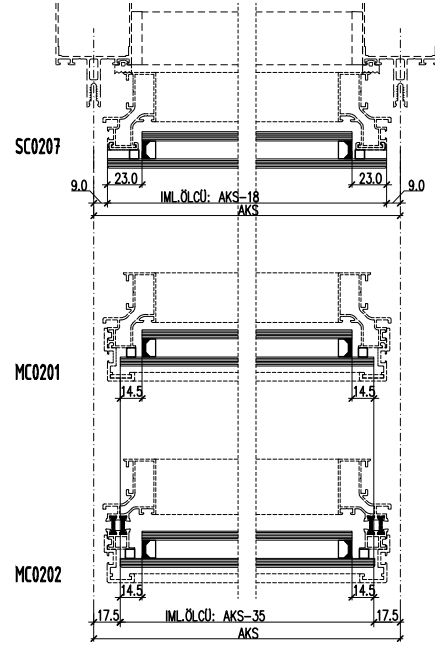
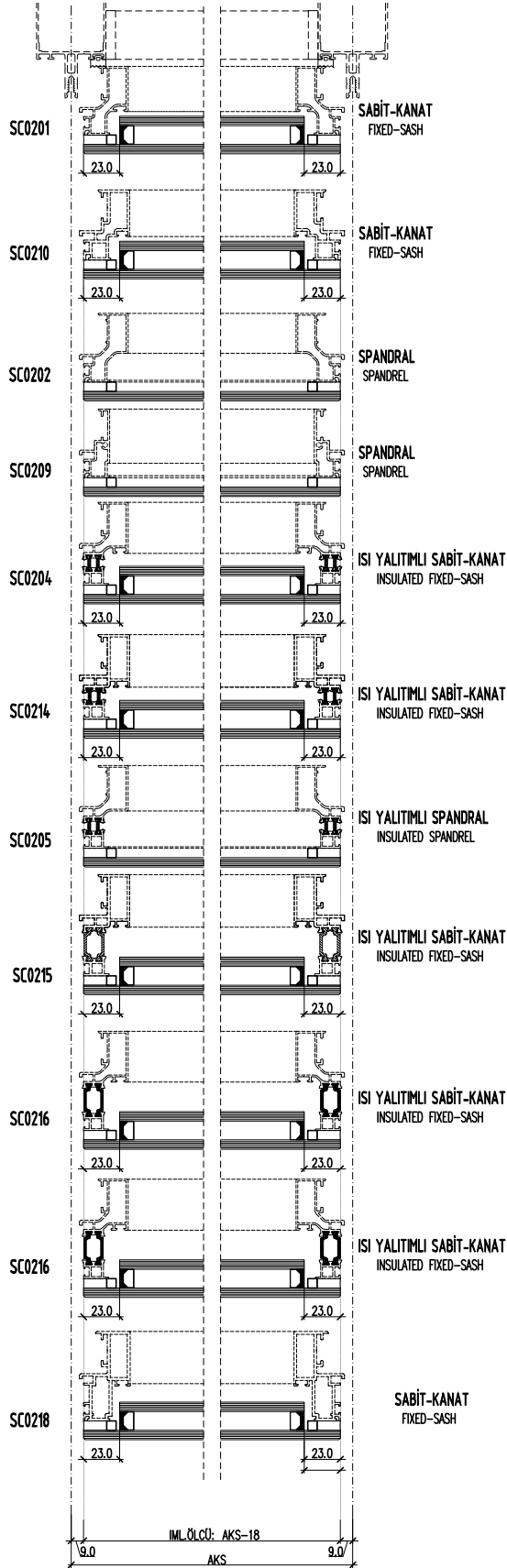

F50 KLASİK SİSTEM
SİLİKON CEPHE
F50 CLASSIC SYSTEM
SILICONE FACADE

İMALAT ŞEMASI
PRODUCTION PLAN

CEPHE İÇİNDEN MONTAJ SİSTEMİ
ALTERNATİF -1-

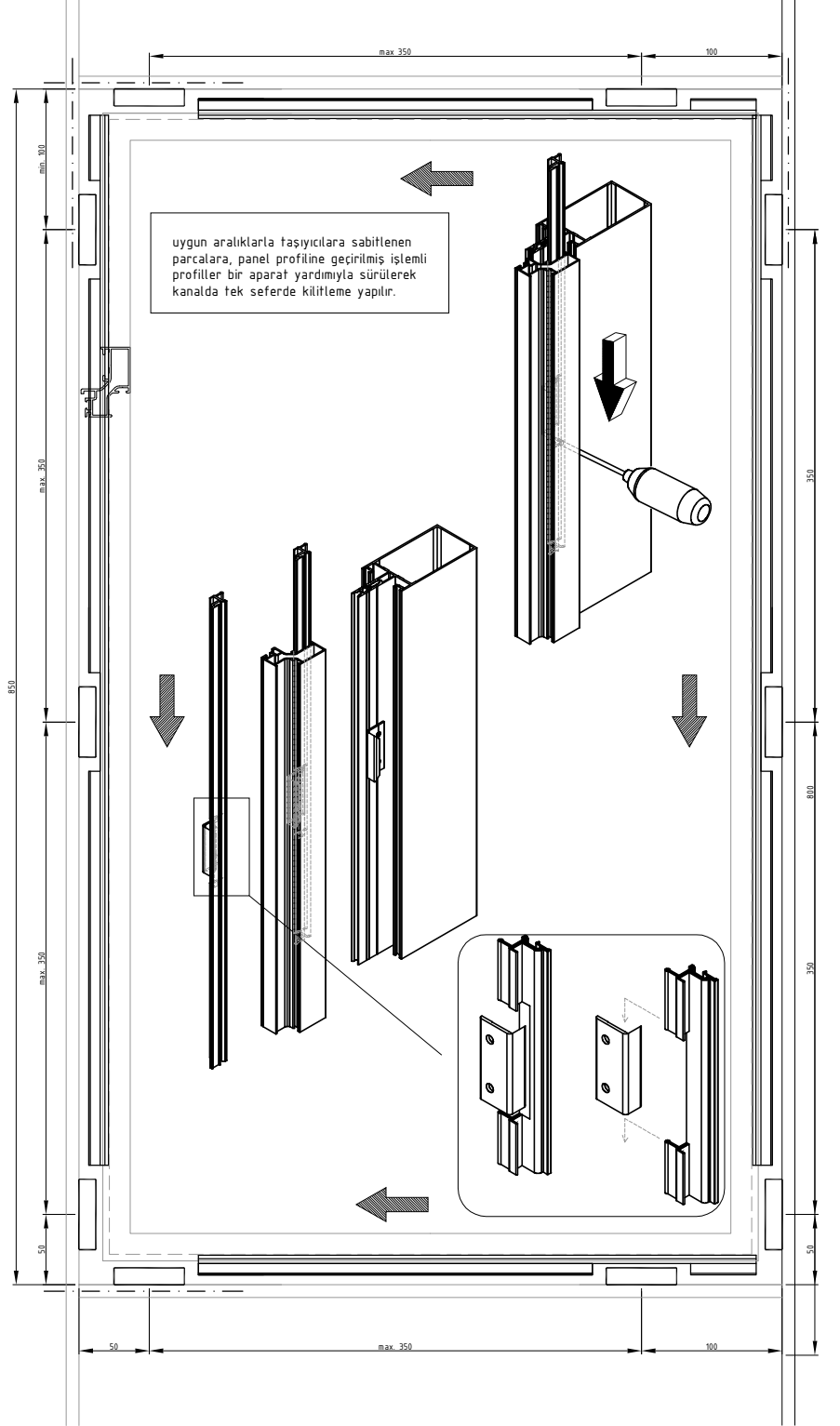
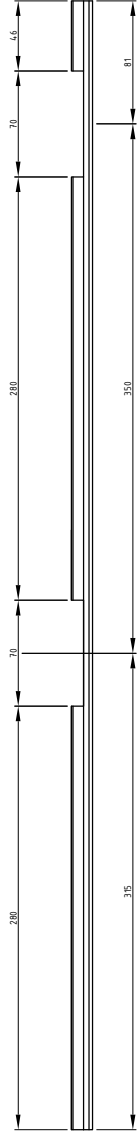
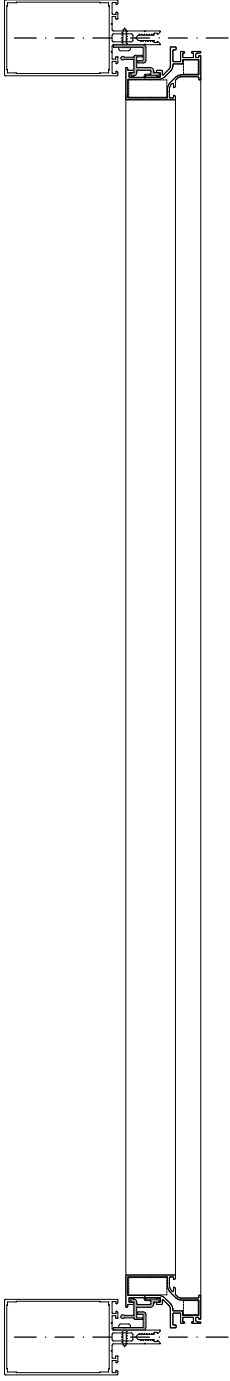
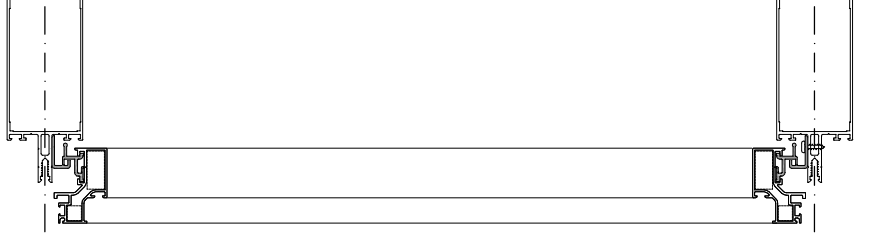

F50 KLASİK SİSTEM

SİLİKON CEPHE

F50 CLASSIC SYSTEM
SILICONE FACADE

AKSESUARLAR
ACCESSOIRES

PANEL OTURTMA TAKOZU (PVC) SUPPORT FOR PANEL (PVC)

SC0305 (yerli) (native)

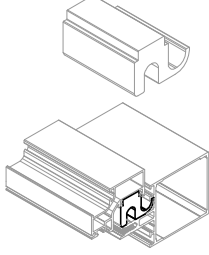

AYARLI PİM KARŞIĞI ADJUSTABLE STRIKER FOR WINDOW

SC0318 (ithal) (import)



SC0318-a (yerli) (native)

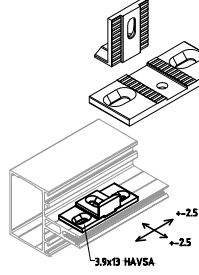

KONDENS PLASTIĞI CONDENSAT PLASTIC

SC0345 (yerli) (native)

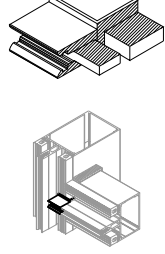

ÇİFT DİLLİ CEPHE KOLU FACADE HANDLE

SC0329 (ithal) (import) SC0329-a (yerli) (native) naturel eloksalli (mat anodized)
SC0330 (ithal) (import) SC0330-a (yerli) (native) pres veya renkli (mill finishand and painted)

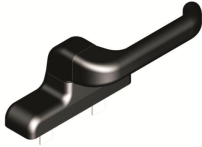

ÇİFT DİLLİ ANAHTARLI CEPHE KOLU FACADE HANDLE (KEY)

SC0333 (ithal) (import) SC0333-a (yerli) (native) naturel eloksalli (mat anodized)
SC0334 (ithal) (import) SC0334-a (yerli) (native) pres veya renkli (mill finishand and painted)



CEPHE KOLU TİJ BAĞLANTI PABUCU CONNECTION BLOCK FOR FACADE HANDLE

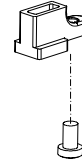

SC0303-a (ithal) (import)
SC0303-b (yerli) (native)

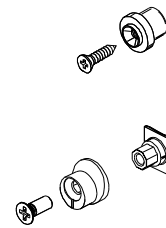
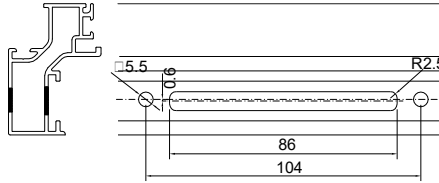
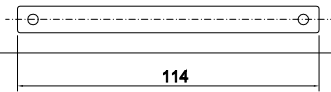
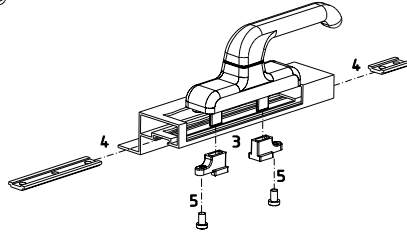
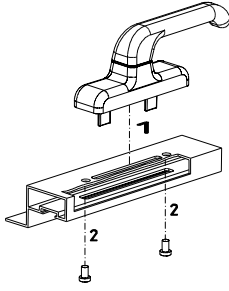
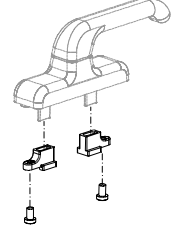

PİM
PIN

W-878 (ithal) (import)
W-878-a (yerli) (native)

AYARLANABİLİR PİM
ADJUSTABLE FASTENING PAWL

W-879 (ithal) (import)
W-879-a (yerli) (native)

KÖŞE HAREKET AKTARICISI MONTION CORNER TRANSMITTER

SC0328 (ithal) (import) SC0328-a (yerli) (native)

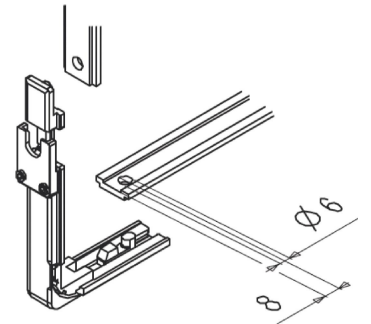

TEK DİLLİ CEPHE KOLU FACADE HANDLE

SC0331 (ithal) (import) naturel eloksalli (mat anodized)
SC0331-a (yerli) (import) naturel eloksalli (mat anodized)
SC0332 (ithal) (native) pres veya renkli (mill finishand and painted)
SC0332-a (yerli) (native) pres veya renkli (mill finishand and painted)

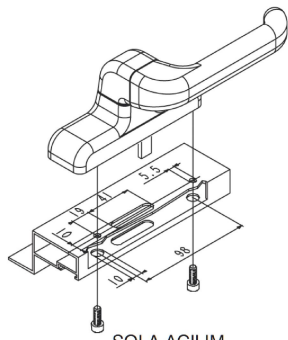

SOLA AÇILIM

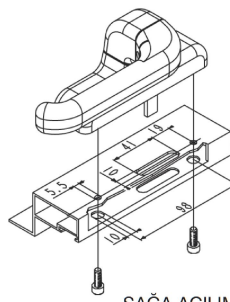

SAĞA AÇILIM

F50 KLASİK SİSTEM
SİLİKON CEPHE
F50 CLASSIC SYSTEM
SILICONE FACADE

İMALAT ŞEMASI
PRODUCTION PLAN

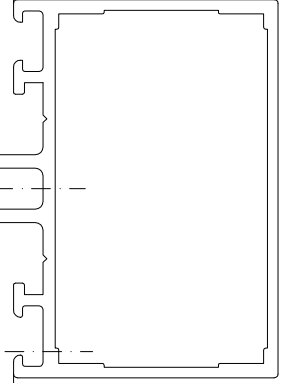
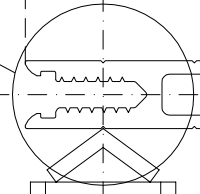
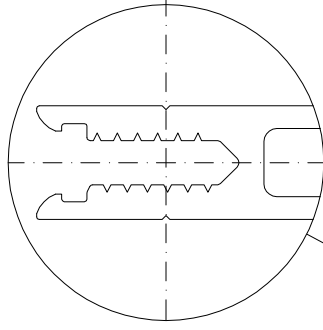
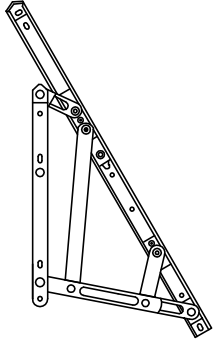

17

- SC0201
- SC0210
- SC0209
- SC0204
- SC0214
- SC0215
- SC0216

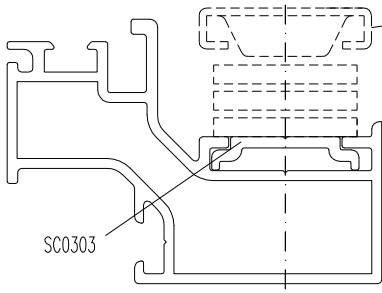

SC0303

- SC0319
- SC0320
- SC0321
- SC0322
- SC0323
- SC0324
- SC0325
- SC0326
- SC0327

F50 KLASİK SİSTEM

SİLİKON CEPHE

F50 CLASSIC SYSTEM
SILICONE FACADE

AKSESUARLAR
ACCESSOIRES

PANEL OTURTMA TAKOZU (PVC) SUPPORT FOR PANEL (PVC)

SC0305 (yerli) (native)

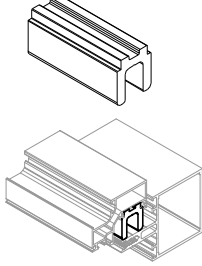

AYARLI PİM KARŞIĞI ADJUSTABLE STRIKER FOR WINDOW

SC0318 (ithal) (import)



SC0318-a (yerli) (native)

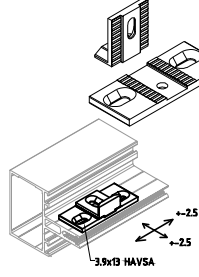

KONDENS PLASTIĞI CONDENSAT PLASTIC

SC0345 (yerli) (native)

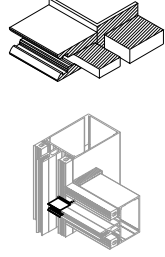

ÇİFT DİLLİ CEPHE KOLU FACADE HANDLE

SC0329 (ithal) (import) SC0329-a (yerli) (native) naturel eloksalli (mat anodized)
SC0330 (ithal) (import) SC0330-a (yerli) (native) pres veya renkli (mill finishand and painted)

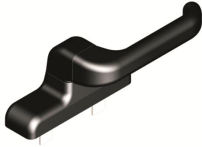

ÇİFT DİLLİ ANAHTARLI CEPHE KOLU FACADE HANDLE (KEY)

SC0333 (ithal) (import) SC0333-a (yerli) (native) naturel eloksalli (mat anodized)
SC0334 (ithal) (import) SC0334-a (yerli) (native) pres veya renkli (mill finishand and painted)



CEPHE KOLU TİJ BAĞLANTI PABUCU CONNECTION BLOCK FOR FACADE HANDLE

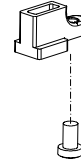

SC0303-a (ithal) (import)
SC0303-b (yerli) (native)

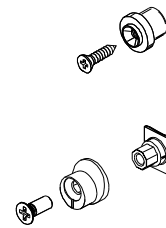
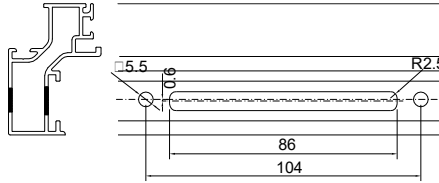
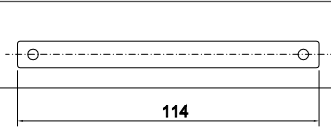
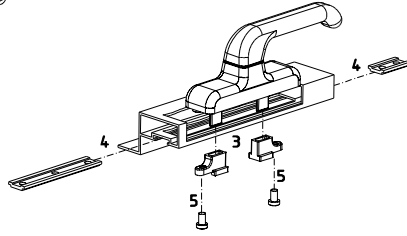
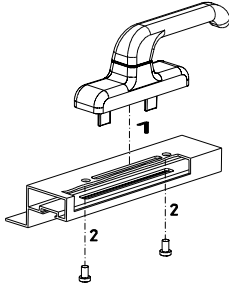
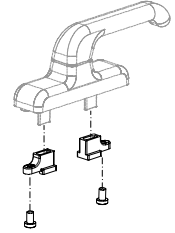

PİM
PIN

W-878 (ithal) (import)
W-878-a (yerli) (native)

AYARLANABİLİR PİM
ADJUSTABLE FASTENING PAWL

W-879 (ithal) (import)
W-879-a (yerli) (native)

KÖŞE HAREKET AKTARICISI MONTION CORNER TRANSMITTER

SC0328 (ithal) (import) SC0328-a (yerli) (native)

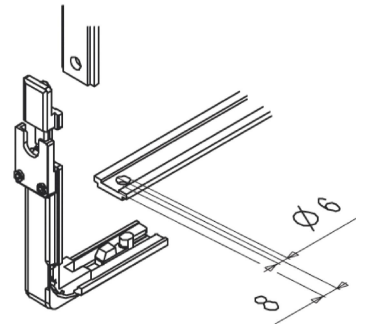

TEK DİLLİ CEPHE KOLU FACADE HANDLE

SC0331 (ithal) (import) naturel eloksalli (mat anodized)
SC0331-a (yerli) (import) naturel eloksalli (mat anodized)
SC0332 (ithal) (native) pres veya renkli (mill finishand and painted)
SC0332-a (yerli) (native) pres veya renkli (mill finishand and painted)

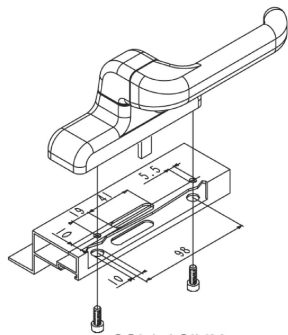

SOLA AÇILIM

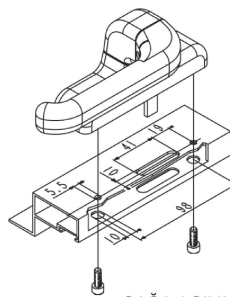

SAĞA AÇILIM

F50 KLASİK SİSTEM

SİLİKON CEPHE

F50 CLASSIC SYSTEM
SILICONE FACADE

AKSESUARLAR
ACCESSOIRES

YÜKSEKLİĞE VE AĞIRLIĞA GÖRE MAXIMUM KANAT GENİSLİKLERİ
WIDTH ACCORDING TO THE WEIGHT AND THE HEIGHT

max. en boy ölçüsü

Tablodaki değerler ithal için geçerlidir.
All values are just for import

(20kg-50kg)

h/kg	20 kg	25 kg	30 kg	35 kg	40 kg	45 kg	50 kg	en
450	1500	1500	1500	1500	1500	1500	1500	weight mm
500	1500	1500	1500	1500	1500	1500	1500	weight mm
550	1500	1500	1500	1500	1500	1500	1500	weight mm
600	1500	1500	1500	1500	1500	1500	1400	weight mm
650	1500	1500	1500	1500	1500	1400	1292	en mm
700	1500	1500	1500	1500	1400	1300	1200	en mm
750	1500	1500	1500	1400	1307	1213	1120	en mm

SC0319 (ithal)
(import)
SC0319-a (yerli)
(native)
TYPE P - 10"
w = 23 mm
l = 261.5 mm
degree of opening 35°

(80kg-135kg)

h/kg	80 kg	90 kg	100 kg	110 kg	120 kg	130 kg	135 kg	en
700	1875	1875	1875	1875	1875	1875	1875	weight mm
800	1875	1875	1875	1875	1875	1875	1875	weight mm
900	1875	1875	1875	1875	1875	1875	1875	weight mm
1000	1875	1875	1875	1875	1875	1875	1875	weight mm
1100	1875	1875	1875	1875	1875	1875	1875	weight mm
1200	1875	1875	1875	1875	1875	1875	1875	weight mm
1300	1875	1875	1875	1875	1875	1875	1846	en mm
1400	1875	1875	1875	1875	1875	1789	1714	en mm
1500	1875	1875	1875	1875	1810	1566	1600	en mm
1600	1875	1875	1875	1829	1697	1875	1500	en mm
1700	1875	1875	1845	1721	1597	1474	1412	en mm

SC0324 (ithal)
(import)
SC0324-a (yerli)
(native)
TYPE P - 20"
w = 23 mm
l = 511.5 mm
degree of opening 25°

(30kg-60kg)

h/kg	30 kg	35 kg	40 kg	45 kg	50 kg	55 kg	60 kg	en
500	1500	1500	1500	1500	1500	1500	1500	weight mm
550	1500	1500	1500	1500	1500	1500	1500	weight mm
600	1500	1500	1500	1500	1500	1500	1500	weight mm
650	1500	1500	1500	1500	1500	1500	1477	en mm
700	1500	1500	1500	1500	1500	1472	1371	en mm
750	1500	1500	1500	1500	1467	1373	1280	en mm
800	1500	1500	1500	1463	1375	1288	1200	en mm
850	1500	1500	1459	1400	1294	1212	1129	en mm

SC0320 (ithal)
(import)
SC0320-a (yerli)
(native)
TYPE P - 12"
w = 23 mm
l = 317.5 mm
degree of opening 35°

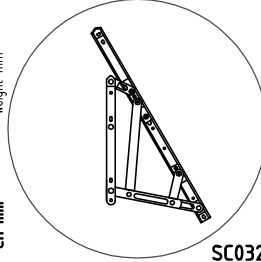

(35kg-69,5kg)

h/kg	35 kg	40 kg	45 kg	50 kg	55 kg	60 kg	65 kg	69 kg	en
550	1625	1625	1625	1625	1625	1625	1625	1625	weight mm
600	1625	1625	1625	1625	1625	1625	1625	1625	weight mm
650	1625	1625	1625	1625	1625	1625	1625	1625	weight mm
700	1625	1625	1625	1625	1625	1625	1625	1625	weight mm
750	1625	1625	1625	1625	1625	1625	1625	1625	weight mm
800	1625	1625	1625	1625	1625	1625	1625	1625	weight mm
850	1625	1625	1625	1625	1625	1604	1529	en mm	
900	1625	1625	1625	1625	1604	1514	1444	en mm	
950	1625	1625	1625	1582	1514	1435	1368	en mm	
1000	1625	1625	1625	1573	1503	1363	1300	en mm	
1050	1625	1625	1565	1498	1432	1298	1238	en mm	

SC0321 (ithal)
(import)
SC0321-a (yerli)
(native)
TYPE P - 14"
w = 23 mm
l = 353.5 mm
degree of opening 35°

(90kg-137kg)

h/kg	90 kg	100 kg	110 kg	120 kg	130 kg	137 kg	en
750	1875	1875	1875	1875	1875	1875	weight mm
900	1875	1875	1875	1875	1875	1875	weight mm
1000	1875	1875	1875	1875	1875	1875	weight mm
1100	1875	1875	1875	1875	1875	1875	weight mm
1200	1875	1875	1875	1875	1875	1875	weight mm
1300	1875	1875	1875	1875	1875	1875	weight mm
1400	1875	1875	1875	1875	1875	1821	en mm
1500	1875	1875	1875	1875	1798	1700	en mm
1600	1875	1875	1875	1875	1686	1594	en mm
1700	1875	1875	1834	1710	1587	1500	en mm
1800	1875	1875	1734	1610	1498	1417	en mm

SC0325 (ithal)
(import)
SC0325-a (yerli)
(native)
TYPE P - 22"
w = 23 mm
l = 556.5 mm
degree of opening 25°

(45kg-88,5kg)

h/kg	45 kg	50 kg	55 kg	60 kg	65 kg	70 kg	75 kg	80 kg	85 kg	88,5kg	en
600	1750	1750	1750	1750	1750	1750	1750	1750	1750	1750	weight mm
650	1750	1750	1750	1750	1750	1750	1750	1750	1750	1750	weight mm
700	1750	1750	1750	1750	1750	1750	1750	1750	1750	1750	weight mm
750	1750	1750	1750	1750	1750	1750	1750	1750	1750	1750	weight mm
800	1750	1750	1750	1750	1750	1750	1750	1750	1750	1750	weight mm
850	1750	1750	1750	1750	1750	1750	1750	1750	1750	1750	weight mm
900	1750	1750	1750	1750	1750	1750	1750	1750	1750	1750	weight mm
950	1750	1750	1750	1750	1750	1750	1750	1750	1750	1750	weight mm
1000	1750	1750	1750	1750	1750	1750	1750	1750	1739	1680	en mm
1050	1750	1750	1750	1750	1750	1750	1750	1738	1657	1600	en mm
1100	1750	1750	1750	1750	1750	1736	1659	1581	1527	en mm	
1150	1750	1750	1750	1750	1734	1660	1586	1513	1461	en mm	
1200	1750	1750	1750	1733	1662	1591	1520	1450	1400	en mm	
1250	1750	1750	1731	1663	1595	1528	1460	1392	1344	en mm	
1300	1750	1750	1730	1665	1560	1534	1470	1403	1338	1292	en mm

SC0322 (ithal)
(import)
SC0322-a (yerli)
(native)
TYPE P - 16"
w = 23 mm
l = 414.5 mm
degree of opening 30°

(90kg-137kg)

h/kg	90 kg	100 kg	110 kg	120 kg	130 kg	139 kg	en
800	1875	1875	1875	1875	1875	1875	weight mm
950	1875	1875	1875	1875	1875	1875	weight mm
1100	1875	1875	1875	1875	1875	1875	weight mm
1200	1875	1875	1875	1875	1875	1875	weight mm
1300	1875	1875	1875	1875	1875	1875	weight mm
1400	1875	1875	1875	1875	1875	1875	weight mm
1500	1875	1875	1875	1875	1875	1800	en mm
1600	1875	1875	1875	1875	1806	1688	en mm
1700	1875	1875	1875	1823	1700	1588	en mm
1800	1875	1875	1839	1722	1605	1500	en mm
1900	1875	1875	1742	1631	1521	1421	en mm

SC0326 (ithal)
(import)
SC0326-a (yerli)
(native)
TYPE P - 24"
w = 23 mm
l = 602.5 mm
degree of opening 25°

(55kg-102kg)

h/kg	55 kg	60 kg	65 kg	70 kg	75 kg	80 kg	85 kg	90 kg	95 kg	102 kg	en
650	1750	1750	1750	1750	1750	1750	1750	1750	1750	1750	weight mm
750	1750	1750	1750	1750	1750	1750	1750	1750	1750	1750	weight mm
850	1750	1750	1750	1750	1750	1750	1750	1750	1750	1750	weight mm
950	1750	1750	1750	1750	1750	1750	1750	1750	1750	1750	weight mm
850	1750	1750	1750	1750	1750	1750	1750	1750	1750	1750	weight mm
1050	1750	1750	1750	1750	1750	1750	1750	1750	1750	1704	en mm
1150	1750	1750	1750	1750	1750	1750	1731	1663	1568	en mm	
1250	1750	1750	1750	1750	1729	1666	1603	1540	1452	en mm	
1350	1750	1750	1750	1728	1667	1606	1546	1485	1400	en mm	
1450	1750	1750	1750	1727	1668	1610	1551	1492	1434	1352	en mm
1500	1750	1750	1750	1669	1613	1556	1499	1443	1386	1307	en mm

SC0323 (ithal)
(import)
SC0323-a (yerli)
(native)
TYPE P - 18"
w = 23 mm
l = 458.5 mm
degree of opening 30°

(90kg-137kg)

h/kg	105 kg	115 kg	125 kg	135 kg	145 kg	155 kg	en
900	1875	1875	1875	1875	1875	1875	weight mm
1100	1875	1875	1875	1875	1875	1875	weight mm
1300	1875	1875	1875	1875	1875	1875	weight mm
1500	1875	1875	1875	1875	1875	1875	weight mm
1600	1875	1875	1875	1875	1875	1875	weight mm
1700	1875	1875	1875	1875	1875	1765	en mm
1800	1875	1875	1875	1875	1816	1667	en mm
1900	1875	1875	1875	1863	1721	1579	en mm
2000	1875	1875	1875	1770	1635	1500	en mm
2100	1875	1875	1814	1685	1557	1429	en mm

SC0327 (ithal)
(import)
SC

F50 KLASİK SİSTEM
SİLİKON CEPHE
F50 CLASSIC SYSTEM
SILICONE FAÇADE

AKSESUARLAR
ACCESSOIRES

DALDIRMA GALVENİZLİ SABİT U ANKRAJ (YATAY BAKLALI)
DIP GALVANIZED FIX "U" ANCHOR (HORIZONTAL)

- SC0338-2 (yerli) (native) L= 80 mm
SC0339-2 (yerli) (native) L= 100 mm
SC0340-2 (yerli) (native) L= 120 mm
SC0341-2 (yerli) (native) L= 150 mm
SC0342-2 (yerli) (native) L= 200 mm

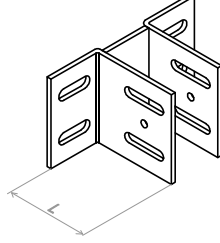

DALDIRMA GALVENİZLİ SABİT U ANKRAJ (DÜŞEY BAKLALI)
DIP GALVANIZED FIX "U" ANCHOR (VERTICAL)

- SC0338-1 (yerli) (native) L= 80 mm
SC0339-1 (yerli) (native) L= 100 mm
SC0340-1 (yerli) (native) L= 120 mm
SC0341-1 (yerli) (native) L= 150 mm
SC0342-1 (yerli) (native) L= 200 mm

