

**KAPAKLI CEPHE**  
COVER FACADE

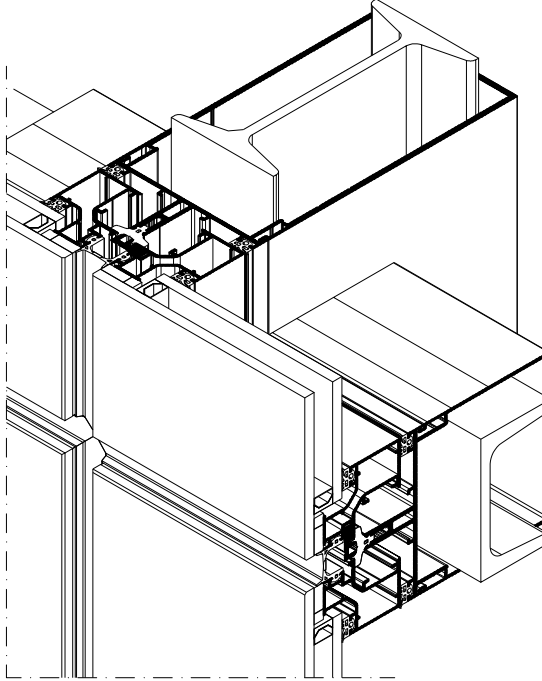









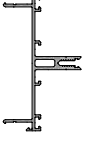

**SİLİKON CEPHE**  
SILICONE FACADE

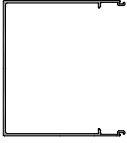
**ÇT94**  
**ÇELİK TAKVİYELİ CEPHE**  
STEEL REINFORCED FACADE

**ÇT94**  
**ÇELİK TAKVİYELİ CEPHE**  
**STEEL REINFORCED FACADE**

**ÜRÜN TEKNİK ÖZELLİKLERİ**  
**PRODUCT'S TECHNICAL FEATURES**

No. Nr.	PROFİL KESİTİ PROFILE VIEW	PROFİL AÇIKLAMASI PROFILE DESCRIPTION	BAĞLANTI PARÇALARI CORNER CLEATS		STATİK STATIC			
					$I_x$ cm <sup>4</sup>	$I_y$ cm <sup>4</sup>	$W_x$ cm <sup>3</sup>	$W_y$ cm <sup>3</sup>
1		<b>ÇT94-101</b> ( 53,8 - 94 ) ( 2 mm ) <b>TAŞIYICI PROFİL</b> MULLION OR TRANSOM PROFILE		1267				
2	  İşaretili profil için satış ekibinden bilgi alınız.	<b>ÇT94-201</b> ( 38 - 49,5 ) ( 13 mm ) <b>ÇİFT CAM PANEL PROFİLİ</b> PANEL PROFILE FOR DOUBLE GLASS	SC0308-a (25,68 mm) SC0307-a (10,25 mm) SC0304-a (50 mm)	796				
3		<b>ÇT94-301</b> ( 91 - 9 ) ( 2 mm ) <b>BASKI PROFİLİ</b> PRESSURE PROFILE	ÇT94-302	788				
4		<b>ÇT94-302</b> ( 20 - 94 ) ( 15 mm ) <b>KAPAK PROFİLİ</b> COVER PROFILE	ÇT94-301	587				
5		<b>ÇT94-303</b> ( 84,6 - 94 ) ( 16 mm ) <b>KAPAK PROFİLİ</b> COVER PROFILE	ÇT94-101	1139				
6		<b>ÇT94-304</b> ( 164,6 - 94 ) ( 2,8 mm ) <b>KAPAK PROFİLİ</b> COVER PROFILE	ÇT94-101	3078				
7		<b>SCO201</b> ( 34,9 - 49,5 ) ( 13 mm ) <b>ÇİFT CAM PANEL PROFİLİ</b> PANEL PROFILE FOR DOUBLE GLASS	SC0308-a (25,68 mm) SC0307-a (10,25 mm) SC0304-a (50 mm)	734				
8		<b>SCO204</b> ( 34,9 - 59,6 ) ( 13 mm ) <b>ÇİFT CAM PANEL PROFİLİ</b> PANEL PROFILE FOR DOUBLE GLASS	SC0308-b (29,74 mm) SC0309-a (6,5 mm) SC0304-a (50 mm)	PVC 970 POLYAMİD 963				
9		<b>SCO207</b> ( 19,1 - 4,9 ) ( 15 mm ) <b>SİLİKON YAPIŞTIRMA PR.</b> SILICONE BONDING PROFILE		109				
10		<b>SCO210</b> ( 36,1 - 50,5 ) ( 2 mm ) <b>ÇİFT CAM PANEL PROFİLİ</b> PANEL PROFILE FOR DOUBLE GLASS	SC0308-a (25,68 mm) SC0307-a (10,25 mm) SC0304-a (50 mm)	1001				

Profil değerleri teoriktir. Ağırlık olarak testimde yapılan tartım geçerlidir.  
Profil imalatları TS EN 12020-2 ve TS EN 755-9 toleransları,  
Moment değerleri EN 14024'e göre hesaplanmıştır.

Profile values are theoretical pre-shipment weight will be valid.  
The tolerances of Profile manufacturing are calculated according to EN 12020-2  
and TS EN 755-9; moment values are calculated according to EN 14024.

**ÇT94**  
**ÇELİK TAKVİYELİ CEPHE**  
**STEEL REINFORCED FACADE**

**ÜRÜN TEKNİK ÖZELLİKLERİ**  
**PRODUCT'S TECHNICAL FEATURES**









No. Nr.	PROFİL KESİTİ PROFILE VIEW	PROFİL NO PROFILE NO	PROFİL AÇIKLAMASI PROFILE DESCRIPTION	BAĞLANTI PARÇALARI CORNER CLEATS	gr/m	STATİK STATIC			
						Ix cm <sup>4</sup>	Iy cm <sup>4</sup>	Wx cm <sup>3</sup>	Wy cm <sup>3</sup>
11		<b>SC0214</b> ( 36.1 - 61.1 ) ( 2 mm )	<b>ÇİFT CAM PANEL PROFİLİ</b> PANEL PROFILE FOR DOUBLE GLASS	SC0308-b (29,74 mm) SC0309-a (6,5 mm) SC0304-a (50 mm)	PVC <b>1275</b> POLYAMİD <b>1268</b>				
12		<b>SC0215</b> ( 33.2 - 73.1 ) ( 2 mm )	<b>ÇİFT CAM PANEL PROFİLİ</b> PANEL PROFILE FOR DOUBLE GLASS	SC0308-b (29,74 mm) SC0309-a (6,5 mm) SC0304-a (50 mm)	PVC <b>1365</b> POLYAMİD <b>1350</b>				
13		<b>SC0216</b> ( 32 - 71.6 ) ( 13 mm )	<b>TEK CAM PANEL PROFİLİ</b> PANEL PROFILE FOR SINGLE GLASS	SC0308-b (29,74 mm) SC0309-a (6,5 mm) SC0304-a (50 mm)	PVC <b>1060</b> POLYAMİD <b>1045</b>				
14		<b>SC0218</b> ( 33.5 - 64.5 ) ( 13 mm )	<b>ÇİFT CAM PANEL PROFİLİ</b> PANEL PROFILE FOR DOUBLE GLASS	SC0308-b (29,74 mm) SC0308-g (19,5 mm) SC0304-a (50 mm)	<b>1241</b>				
15		<b>SC0304</b> ( 19 - 7.6 ) ( 2.8 mm )	<b>DIŞTAN BAĞLANTI PROFİLİ</b> OUTSIDE CONNECTION PROFILE		<b>250</b>				
16		<b>SC0307</b> ( 55 - 55 ) ( 9.71 mm )	<b>KÖŞE BİRLEŞTİRME PROFİLİ</b> CORNER CLEATS PROFILE		<b>1737</b>				
17		<b>SC0308</b> ( 55 - 55 ) ( 11.82 mm )	<b>KÖŞE BİRLEŞTİRME PROFİLİ</b> CORNER CLEATS PROFILE		<b>2313</b>				
18		<b>SC0309</b> ( 55 - 55 ) ( 6.9 mm )	<b>KÖŞE BİRLEŞTİRME PROFİLİ</b> CORNER CLEATS PROFILE		<b>1573</b>				
19		<b>SC0312</b> ( 25.1 - 4.2 ) ( 2 mm )	<b>CAM OTURTMA PROFİLİ</b> GLAZING SUPPORT FOR SASH PROFILE		<b>147</b>				
20		<b>SC0350</b> ( 23.2 - 6.7 ) ( 12 mm )	<b>CAM OTURTMA PROFİLİ</b> GLAZING SUPPORT FOR SASH PROFILE		<b>140</b>				

Profil değerleri teoriktir. Ağırlık olarak testimde yapılan tartım geçerlidir.  
Profil imalatları TS EN 12020-2 ve TS EN 755-9 toleransı,  
Moment değerleri EN 14024'e göre hesaplanmıştır.

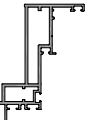
Profile values are theoretical pre-shipment weight will be valid.  
The tolerances of Profile manufacturing are calculated according to EN 12020-2  
and TS EN 755-9; moment values are calculated according to EN 14024.

**ÇT94**  
**ÇELİK TAKVİYELİ CEPHE**  
**STEEL REINFORCED FACADE**

**ÜRÜN TEKNİK ÖZELLİKLERİ**  
**PRODUCT'S TECHNICAL FEATURES**





No. Nr.	PROFİL KESİTİ PROFILE VIEW	PROFİL NO PROFILE NO	PROFİL AÇIKLAMASI PROFILE DESCRIPTION	BAĞLANTI PARÇALARI CORNER CLEATS	gr/m	STATİK STATIC			
						$I_x$ cm <sup>4</sup>	$I_y$ cm <sup>4</sup>	$W_x$ cm <sup>3</sup>	$W_y$ cm <sup>3</sup>
21		<b>KC0201</b> ( 54,6 - 59 ) (13 mm)	<b>SAKLI KANAT KASA PR.</b> OUTER FRAME PROFILE	SC0307-b (27 mm) SC0309-b (8,55 mm)	737				
22		<b>KC0202</b> ( 53,2 - 70,6 ) (13 mm)	<b>SAKLI KANAT KASA PR.</b> OUTER FRAME PROFILE	SC0309-c (18,9 mm)	792				
23		<b>KC0203</b> ( 46,9 - 53,9 ) (13 mm)	<b>SAKLI KANAT KASA PR.</b> OUTER FRAME PROFILE	SC0309-c (18,9 mm)	662				
24		<b>KC0204</b> ( 59,5 - 81,3 ) (2,0 mm)	<b>SAKLI KANAT KASA PR.</b> OUTER FRAME PROFILE	SC0308-h (9,9 mm) SC0309-j (52,8 mm)	1463				
25		<b>KC0331</b> ( 20 - 11 ) (12 mm)	<b>TEK CAM ADAPTÖRÜ PR.</b> SINGLE GLAZING ADAPTER PROFILE		207				
26		<b>KC0332</b> ( 22 - 11 ) (12 mm)	<b>TEK CAM ADAPTÖRÜ PR.</b> SINGLE GLAZING ADAPTER PROFILE		218				
27		<b>KC0333</b> ( 16 - 11 ) (12 mm)	<b>TEK CAM ADAPTÖRÜ PR.</b> SINGLE GLAZING ADAPTER PROFILE		179				
28		<b>KC0334</b> ( 18 - 11 ) (12 mm)	<b>TEK CAM ADAPTÖRÜ PR.</b> SINGLE GLAZING ADAPTER PROFILE		192				
29		<b>KC0336</b> ( 33,2 - 9,4 ) ( 2 mm )	<b>TEK CAM ADAPTÖRÜ PR.</b> SINGLE GLAZING ADAPTER PROFILE		305				
30		<b>KC0350</b> ( 6 - 11 ) ( 1 mm )	<b>TEK CAM ADAPTÖRÜ PR.</b> SINGLE GLAZING ADAPTER PROFILE		96				

Profil değerleri teoriktir. Ağırlık olarak testimde yapılan tartım geçerlidir.  
Profil imalatları TS EN 12020-2 ve TS EN 755-9 toleransı,  
Moment değerleri EN 14024'e göre hesaplanmıştır.

Profile values are theoretical pre-shipment weight will be valid.  
The tolerances of Profile manufacturing are calculated according to EN 12020-2  
and TS EN 755-9; moment values are calculated according to EN 14024.

**ÇT94**  
**ÇELİK TAKVİYELİ CEPHE**  
**STEEL REINFORCED FACADE**

**ÜRÜN TEKNİK ÖZELLİKLERİ**  
**PRODUCT'S TECHNICAL FEATURES**

No. Nr.	PROFİL KESİTİ PROFILE VIEW	PROFİL NO PROFILE NO	PROFİL AÇIKLAMASI PROFILE DESCRIPTION	BAĞLANTI PARÇALARI CORNER CLEATS	gr/m	STATİK STATIC			
						Ix cm <sup>4</sup>	Iy cm <sup>4</sup>	Wx cm <sup>3</sup>	Wy cm <sup>3</sup>
31		<b>KC0351</b> ( 14 - 11 ) ( 12 mm )	<b>TEK CAM ADAPTÖRÜ PR.</b> SINGLE GLAZING ADAPTER PROFILE		151				
32	  İşaretili profil için satış ekibinden bilgi alınız.	<b>KC0352</b> ( 35 - 50 ) ( 17 mm )	<b>TEK CAM ADAPTÖRÜ PR.</b> SINGLE GLAZING ADAPTER PROFILE		270				
33			<b>T1J PROFİLİ</b> PUSHING ROD PROFILE						
34									
35									
36									
37									
38									
39									
40									

Profil değerleri teoriktir. Ağırlık olarak testimde yapılan tartım geçerlidir.  
Profil imalatları TS EN 12020-2 ve TS EN 755-9 toleransı,  
Moment değerleri EN 14024'e göre hesaplanmıştır.

Profile values are theoretical pre-shipment weight will be valid.  
The tolerances of Profile manufacturing are calculated according to EN 12020-2  
and TS EN 755-9; moment values are calculated according to EN 14024.

**ÇT94**  
**ÇELİK TAKVİYELİ CEPHE**  
**STEEL REINFORCED FACADE**

**ÜRÜN TEKNİK ÖZELLİKLERİ**  
**PRODUCT'S TECHNICAL FEATURES**

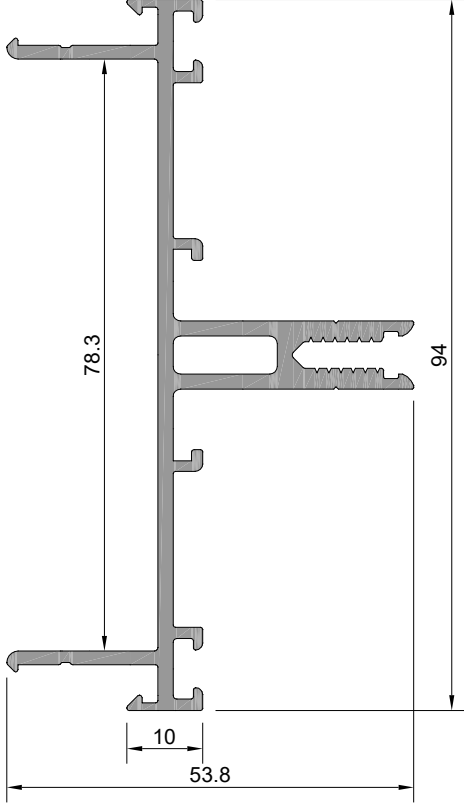

Profil No: ÇT94-101  
Ağırlık : 1267 gr/m

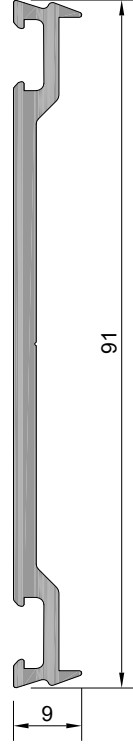

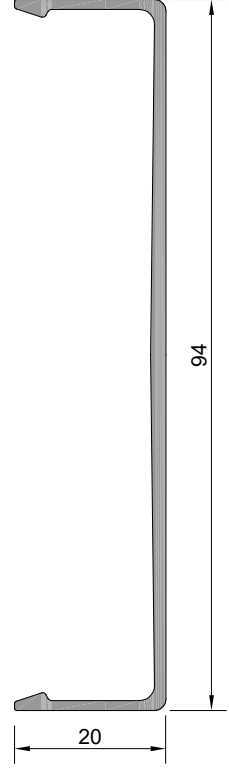

Profil No: ÇT94-301  
Ağırlık : 788 gr/m

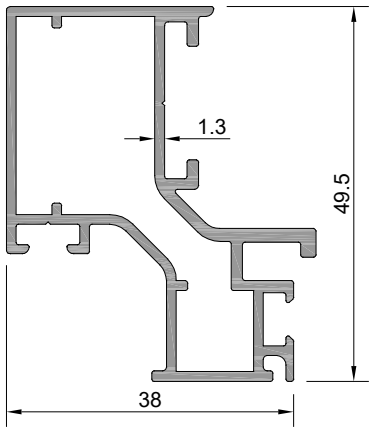

Profil No: ÇT94-302  
Ağırlık : 587 gr/m



Profil No: ÇT94-201   
Ağırlık : 796 gr/m  
 İşaretili profil için satış ekibinden bilgi alınır.



SC0308-a



SC0304-a



SC0307-a

**ÇT94**  
**ÇELİK TAKVİYELİ CEPHE**  
STEEL REINFORCED FACADE

**ÜRÜN TEKNİK ÖZELLİKLERİ**  
PRODUCT'S TECHNICAL FEATURES

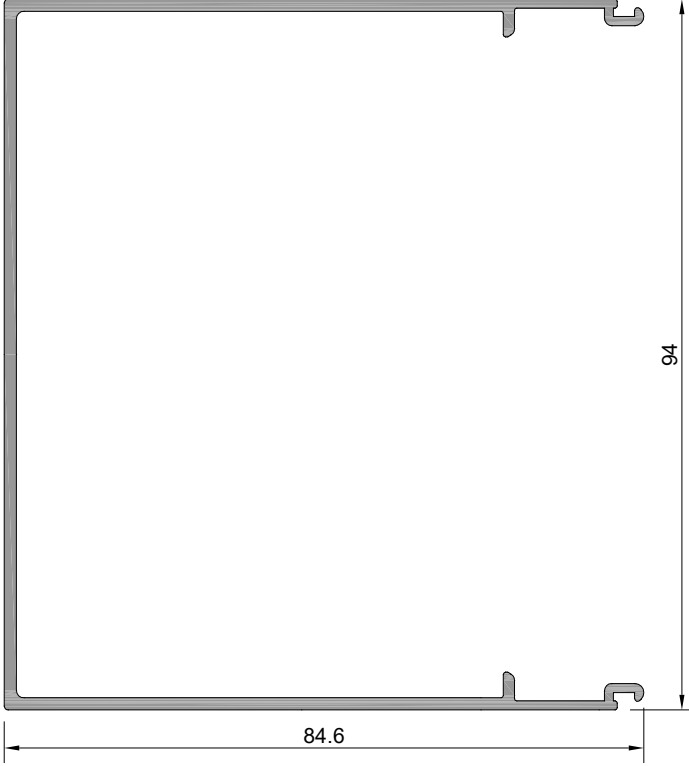

Profil No: ÇT94-303

Ağırlık : 1139 gr/m

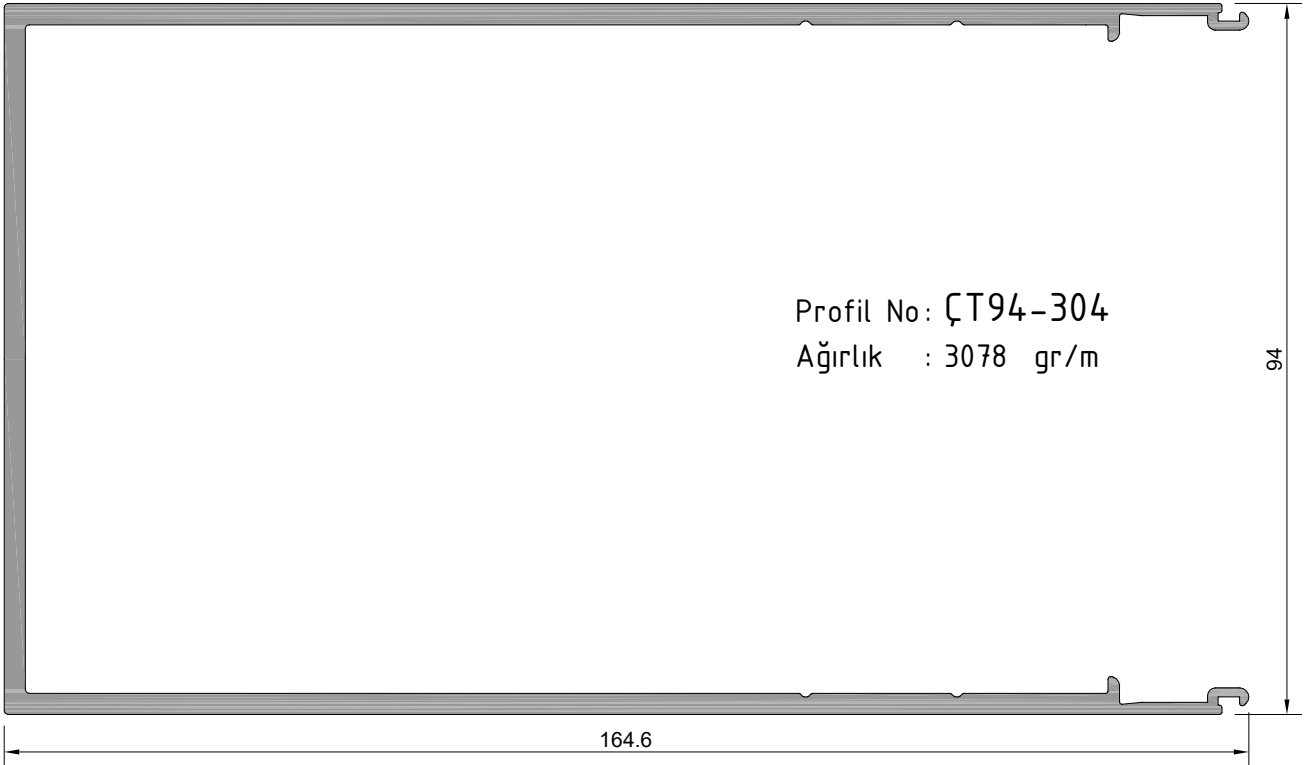

Profil No: ÇT94-304

Ağırlık : 3078 gr/m

**ÇT94**  
**ÇELİK TAKVİYELİ CEPHE**  
STEEL REINFORCED FACADE

**ÜRÜN TEKNİK ÖZELLİKLERİ**  
PRODUCT'S TECHNICAL FEATURES

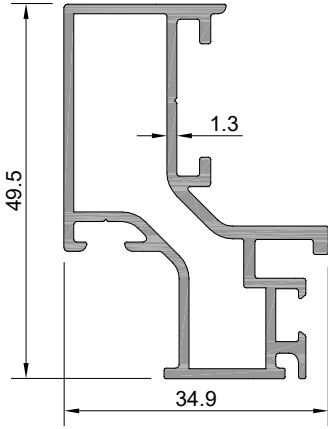

Profil No: SC0201  
Ağırlık : 734 gr/m

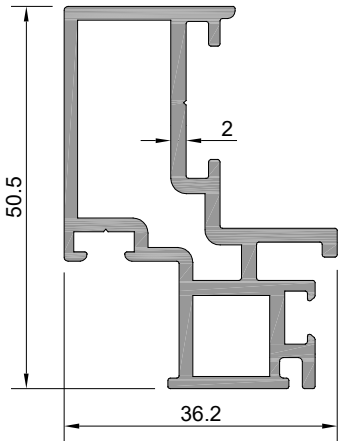
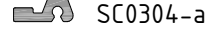

Profil No: SC0210  
Ağırlık : 1001 gr/m

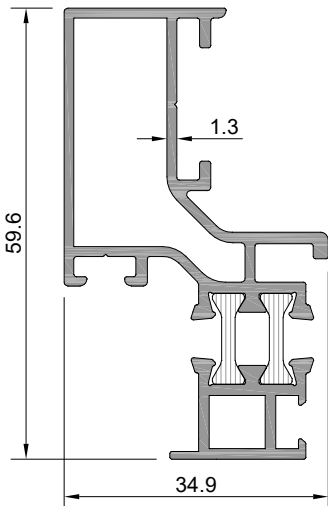
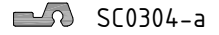

Profil No: SC0204

Ağırlık PVC : 970 gr/m

Ağırlık POLY : 963 gr/m





**ÇT94**  
**ÇELİK TAKVİYELİ CEPHE**  
STEEL REINFORCED FACADE

**ÜRÜN TEKNİK ÖZELLİKLERİ**  
PRODUCT'S TECHNICAL FEATURES

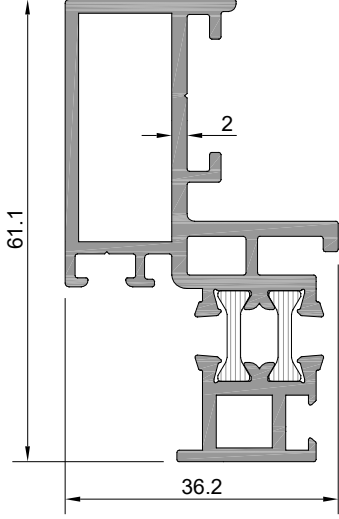

Profil No: **ŞC0214**

Ağırlık PVC	: 1275	gr/m
Ağırlık POLY	: 1268	gr/m

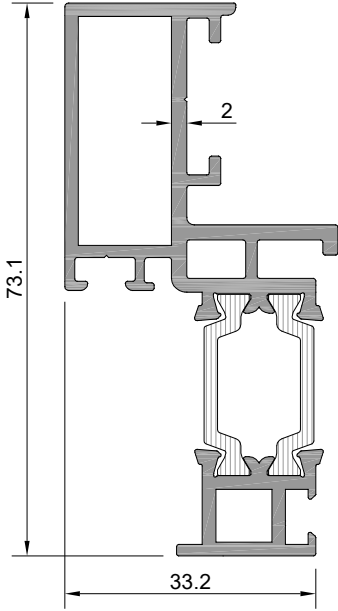
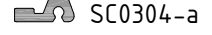

Profil No: **ŞC0215**

Ağırlık PVC	: 1365	gr/m
Ağırlık POLY	: 1350	gr/m



**ÇT94**  
**ÇELİK TAKVİYELİ CEPHE**  
STEEL REINFORCED FACADE

**ÜRÜN TEKNİK ÖZELLİKLERİ**  
PRODUCT'S TECHNICAL FEATURES

Profil No: SC0216

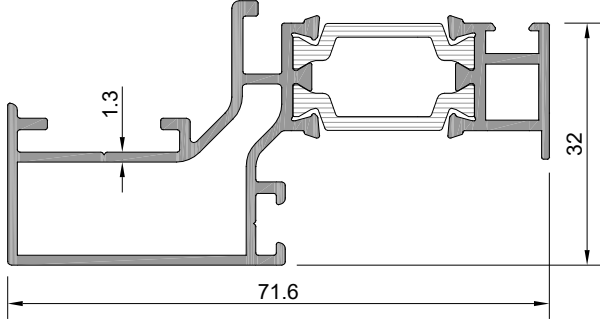

Ağırlık PVC : 1060 gr/m

Ağırlık POLY: 1045 gr/m

Profil No: SC0218

Ağırlık : 1241 gr/m

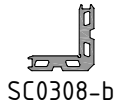
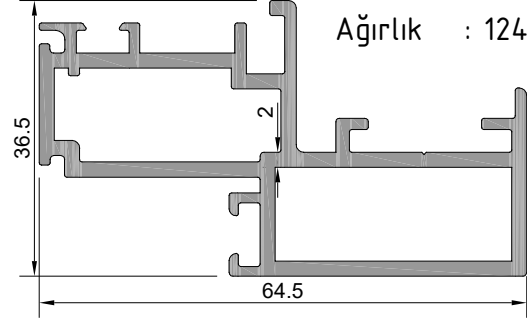

SC0308-b

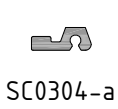

SC0304-a



SC0309-a

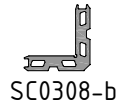

SC0308-b

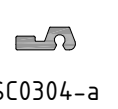

SC0304-a



SC0308-g

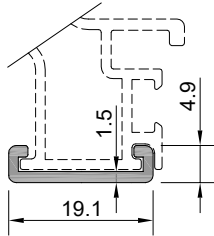

Profil No: SC0207

Ağırlık : 109 gr/m

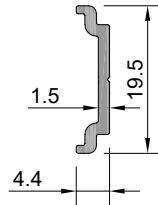

Profil No: SC0303

Ağırlık : 96 gr/m

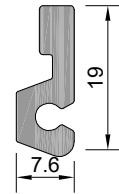

Profil No: SC0304

Ağırlık : 250 gr/m

SC0304-a 50 mm 100 adet/pcs

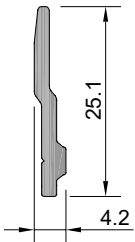

Profil No: SC0312

Ağırlık : 147 gr/m

SC0312-a 50 mm 100 adet/pcs

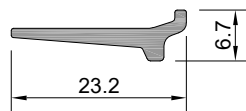

Profil No: SC0350

Ağırlık : 140 gr/m

SC0350-a 50 mm 100 adet/pcs

ÇT94  
ÇELİK TAKVİYELİ CEPHE  
STEEL REINFORCED FACADE

PAZIRCI ÇELİK KÖRFEZLERİ  
PROFİLLERİN ÜRETİCİSİ

SC0201

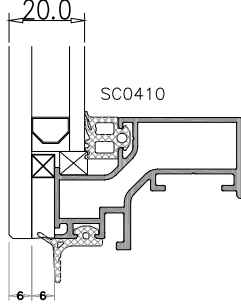

SC0210

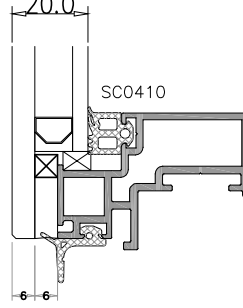

SC0204

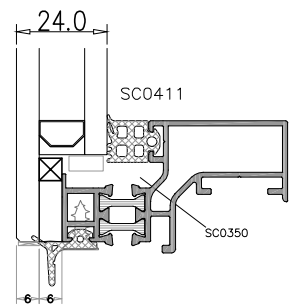
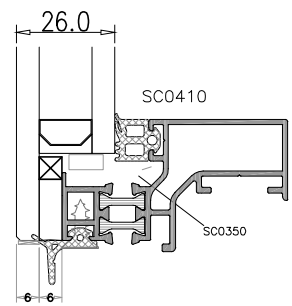
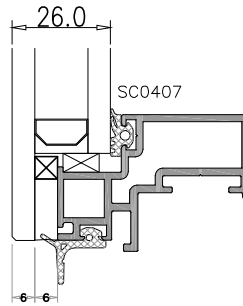
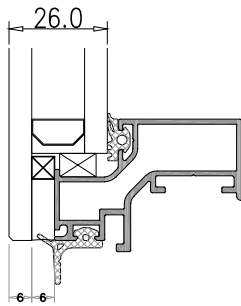
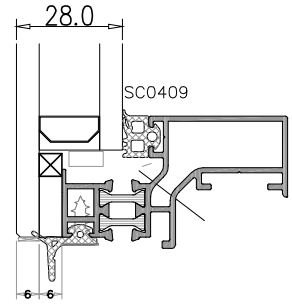
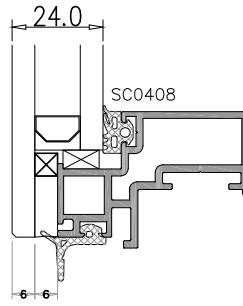
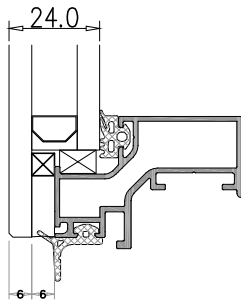
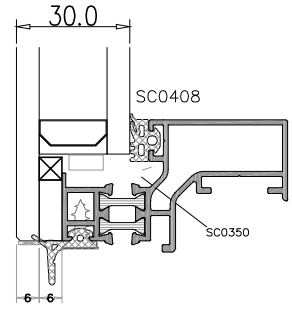
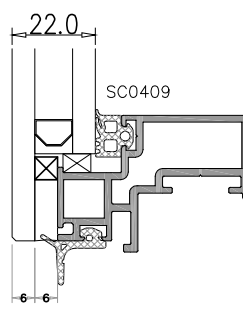
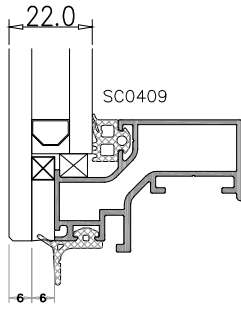
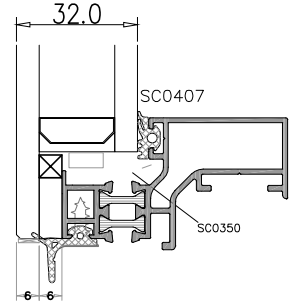

ÇT94  
ÇELİK TAKVİYELİ CEPHE  
STEEL REINFORCED FACADE

ÜRÜN TEKNİK ÖZELLİKLERİ  
PRODUCT'S TECHNICAL FEATURES

SC0214

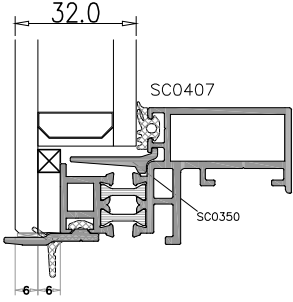

SC0215

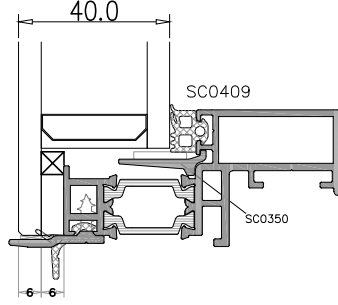

SC0216

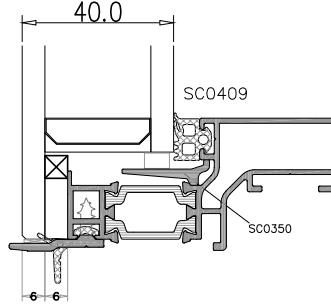

SC0218

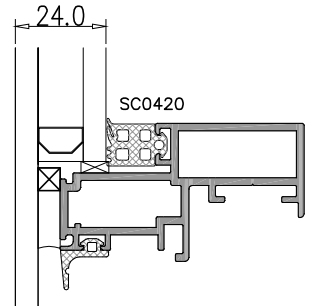
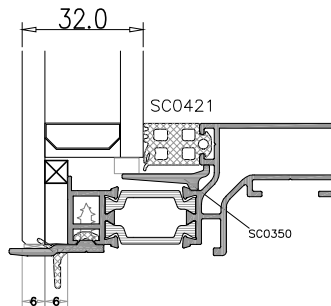
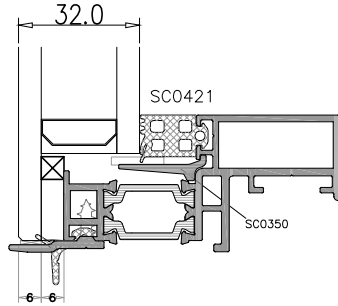
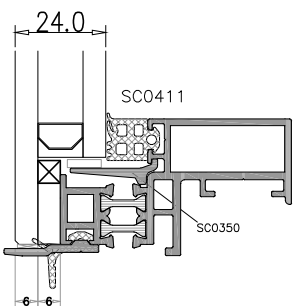
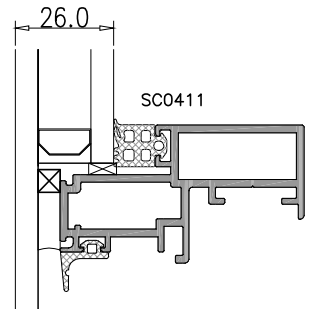
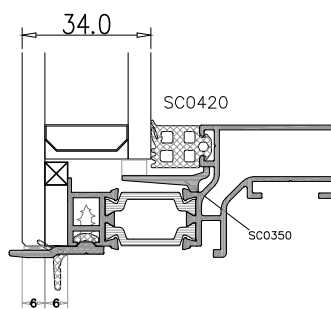
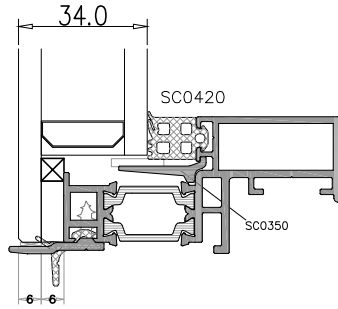
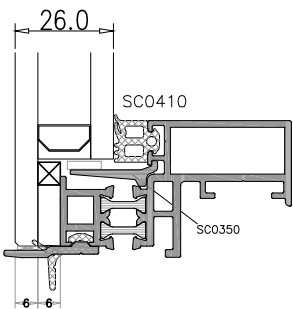
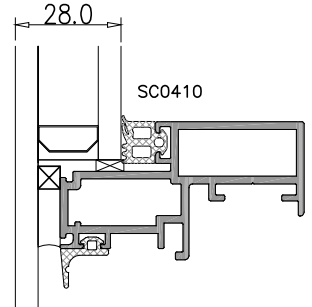
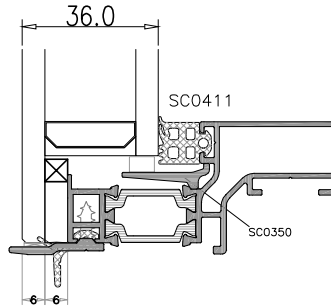
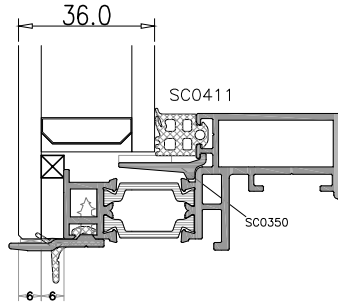
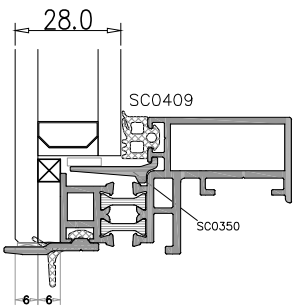
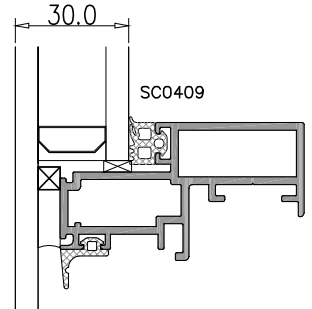
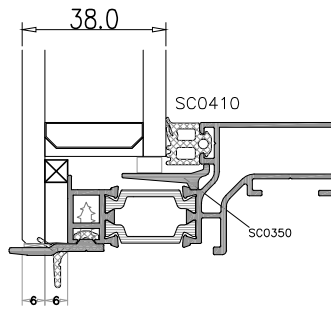
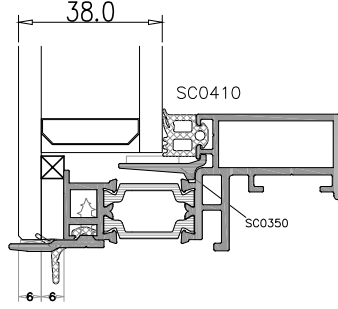
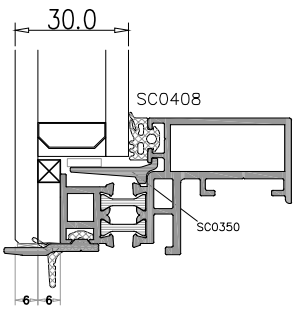
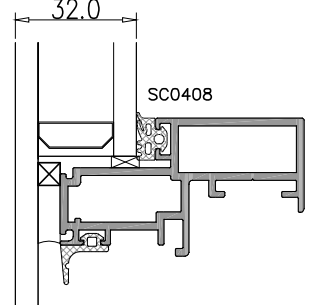

Profil değerleri teoriktir. Ağırlık olarak testimde yapılan tartım geçerlidir.  
Profil imalatları TS EN 12020-2 ve TS EN 755-9 toleransı,  
Moment değerleri EN 14024'e göre hesaplanmıştır.

Profile values are theoretical pre-shipment weight will be valid.  
The tolerances of Profile manufacturing are calculated according to EN 12020-2  
and TS EN 755-9; moment values are calculated according to EN 14024.

**ÇT94**  
**ÇELİK TAKVİYELİ CEPHE**  
STEEL REINFORCED FACADE

ÜRÜN TEKNİK ÖZELLİKLERİ  
PRODUCT'S TECHNICAL FEATURES

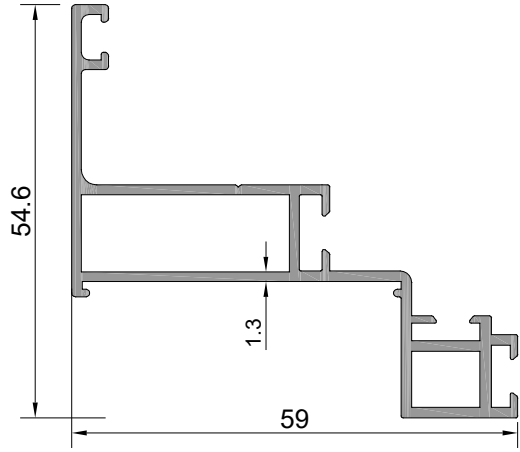

Profil No: KC0201  
Ağırlık : 737 gr/m

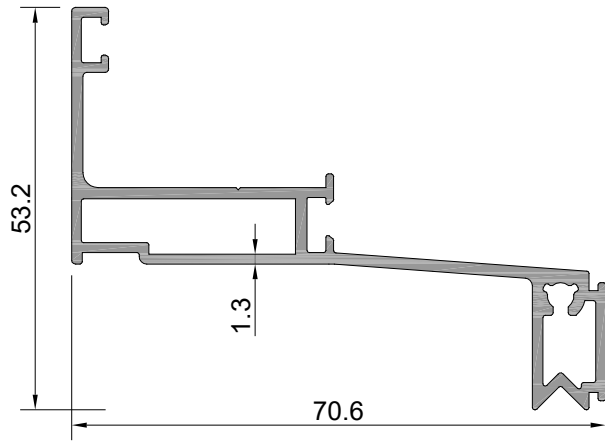

Profil No: KC0202  
Ağırlık : 792 gr/m

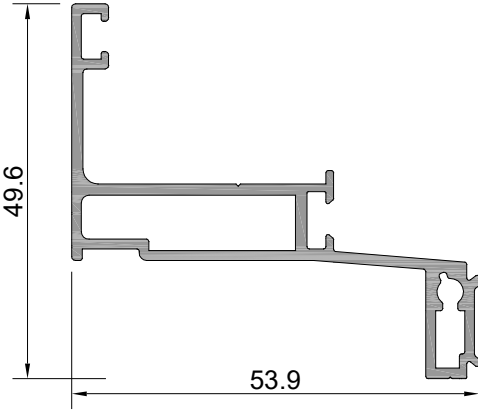

Profil No: KC0203  
Ağırlık : 662 gr/m

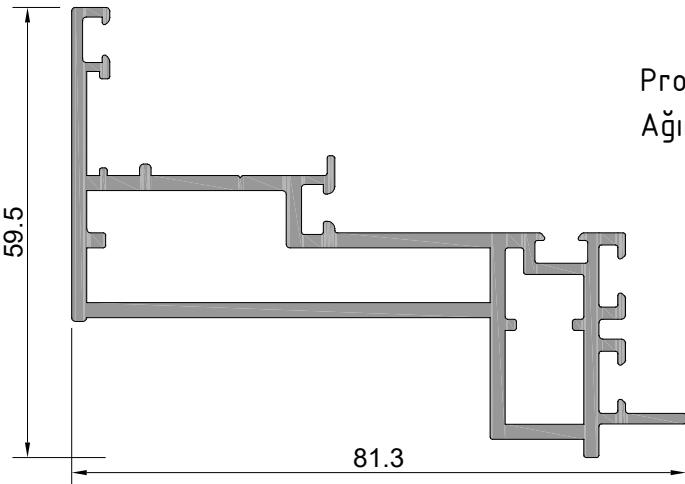

Profil No: KC0204  
Ağırlık : 1463 gr/m



**ÇT94**  
**ÇELİK TAKVİYELİ CEPHE**  
STEEL REINFORCED FACADE

ÜRÜN TEKNİK ÖZELLİKLERİ  
PRODUCT'S TECHNICAL FEATURES

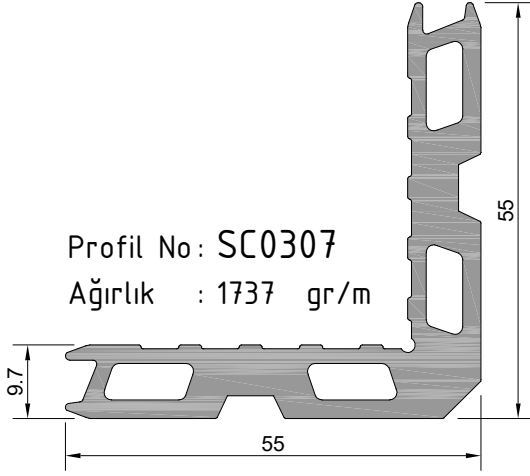

SC0307-a	10.25mm	100 adet/pcs	SC0307-f	25.6mm	100 adet/pcs
SC0307-b	27mm	100 adet/pcs	SC0307-g	6mm	100 adet/pcs
SC0307-c	8.5mm	100 adet/pcs	SC0307-h	4.7mm	100 adet/pcs
SC0307-d	23.9mm	100 adet/pcs	SC0307-i	26.28mm	100 adet/pcs
SC0307-e	6.3mm	100 adet/pcs	SC0307-j	29.5mm	100 adet/pcs

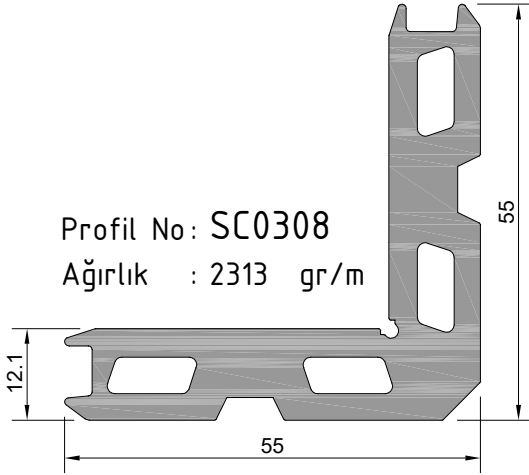

SC0308-a	25.68mm	100 adet/pcs
SC0308-b	29.74mm	100 adet/pcs
SC0308-c	24.36mm	100 adet/pcs
SC0308-d	10.30mm	100 adet/pcs
SC0308-e	6.70mm	100 adet/pcs
SC0308-f	23mm	100 adet/pcs
SC0308-g	19.50mm	100 adet/pcs

SC0308-h	9.9mm	100 adet/pcs
----------	-------	--------------

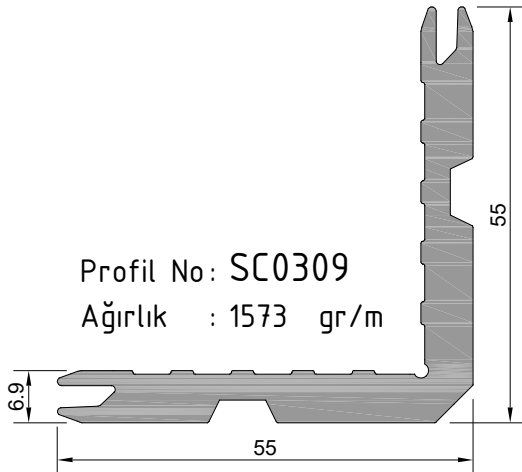

SC0309-a	6.5mm	100 adet/pcs	SC0309-f	4.7mm	100 adet/pcs
SC0309-b	8.5mm	100 adet/pcs	SC0309-g	54.2mm	100 adet/pcs
SC0309-c	18.9mm	100 adet/pcs	SC0309-h	23.8mm	100 adet/pcs
SC0309-d	20mm	100 adet/pcs	SC0309-i	48.2mm	100 adet/pcs
SC0309-e	25.3mm	100 adet/pcs	SC0309-j	52.8mm	100 adet/pcs

**ÇT94**  
**ÇELİK TAKVİYELİ CEPHE**  
STEEL REINFORCED FACADE

**ÜRÜN TEKNİK ÖZELLİKLERİ**  
PRODUCT'S TECHNICAL FEATURES

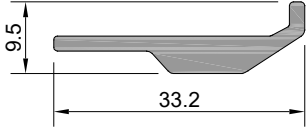

Profil No: KC0336  
Ağırlık : 305 gr/m

KC0336-a	50 mm	100 adet/pcs
----------	-------	--------------

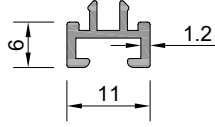

Profil No: KC0350  
Ağırlık : 96 gr/m

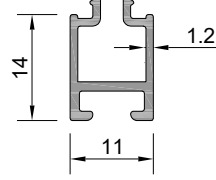

Profil No: KC0351  
Ağırlık : 151 gr/m

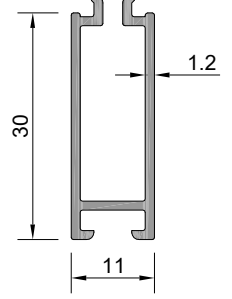

Profil No: KC0352 ⚠  
Ağırlık : 270 gr/m  
⚠ İşaretili profil için satış ekibinden bilgi alınız.

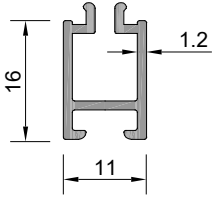

Profil No: KC0333  
Ağırlık : 179 gr/m

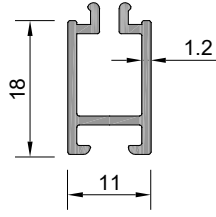

Profil No: KC0334  
Ağırlık : 192 gr/m

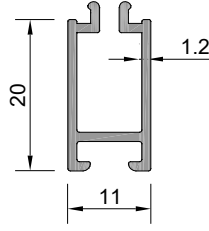

Profil No: KC0331  
Ağırlık : 207 gr/m

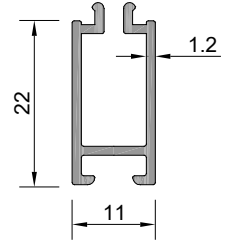

Profil No: KC0332  
Ağırlık : 218 gr/m

**ÇT94**  
**ÇELİK TAKVİYELİ CEPHE**  
STEEL REINFORCED FACADE

**SABİT - SABİT**  
FIXED-FIXED

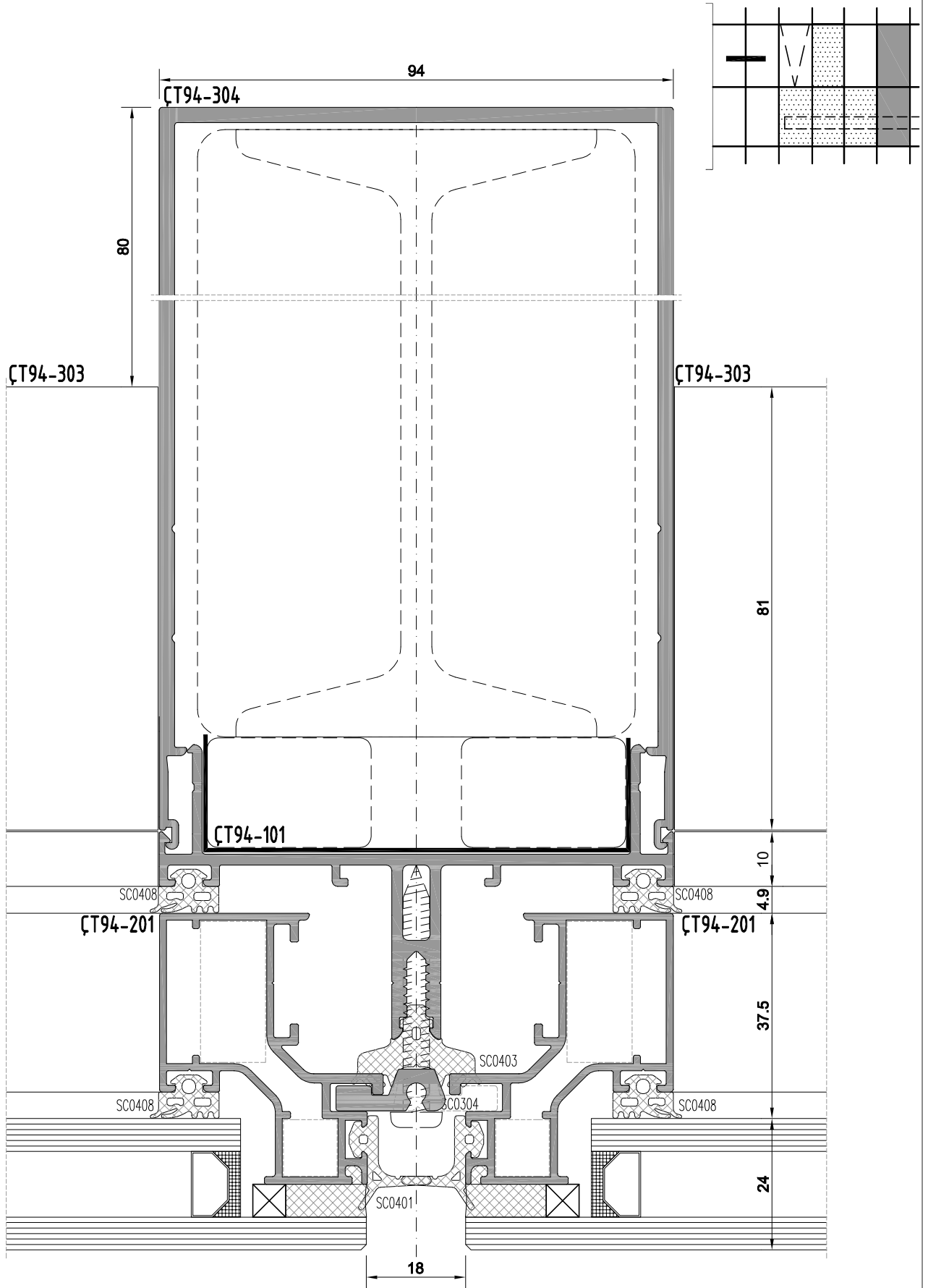





**ÇT94**  
**ÇELİK TAKVİYELİ CEPHE**  
STEEL REINFORCED FAÇADE

**SABİT - SABİT**  
FIXED-FIXED

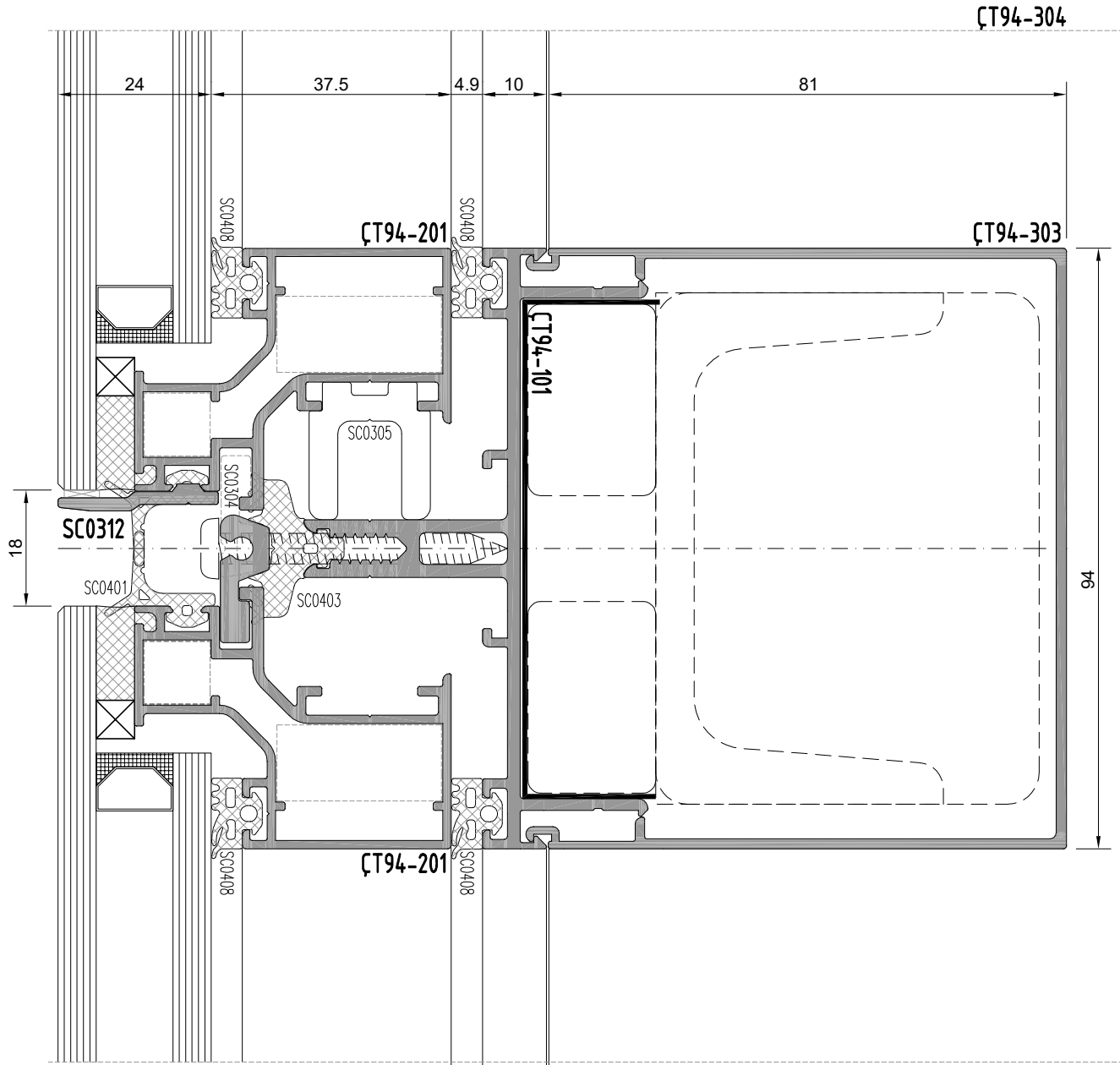
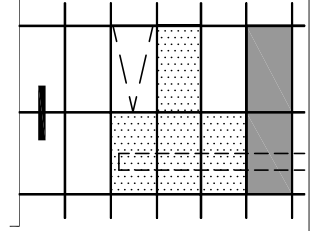

**ÇT94**  
**ÇELİK TAKVİYELİ CEPHE**  
STEEL REINFORCED FAÇADE

**KANAT - SPANDREL**  
SASH-SPANDREL

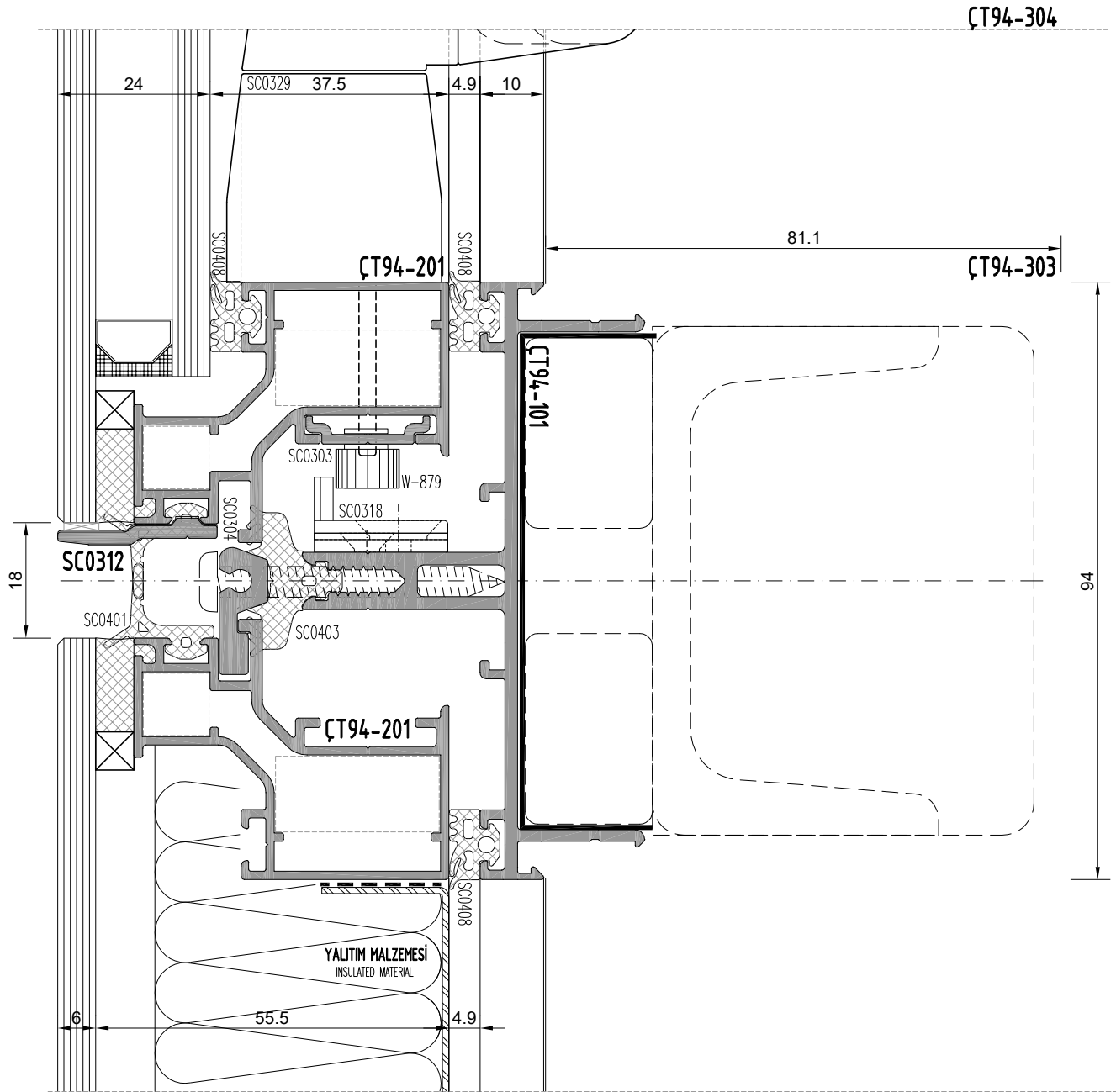
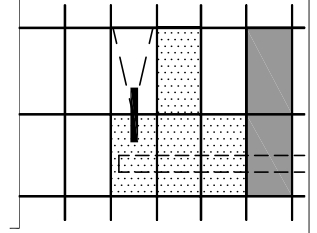



**ÇT94**  
**ÇELİK TAKVİYELİ CEPHE**  
STEEL REINFORCED FAÇADE

**SABİT - KANAT**  
FIXED-SASH

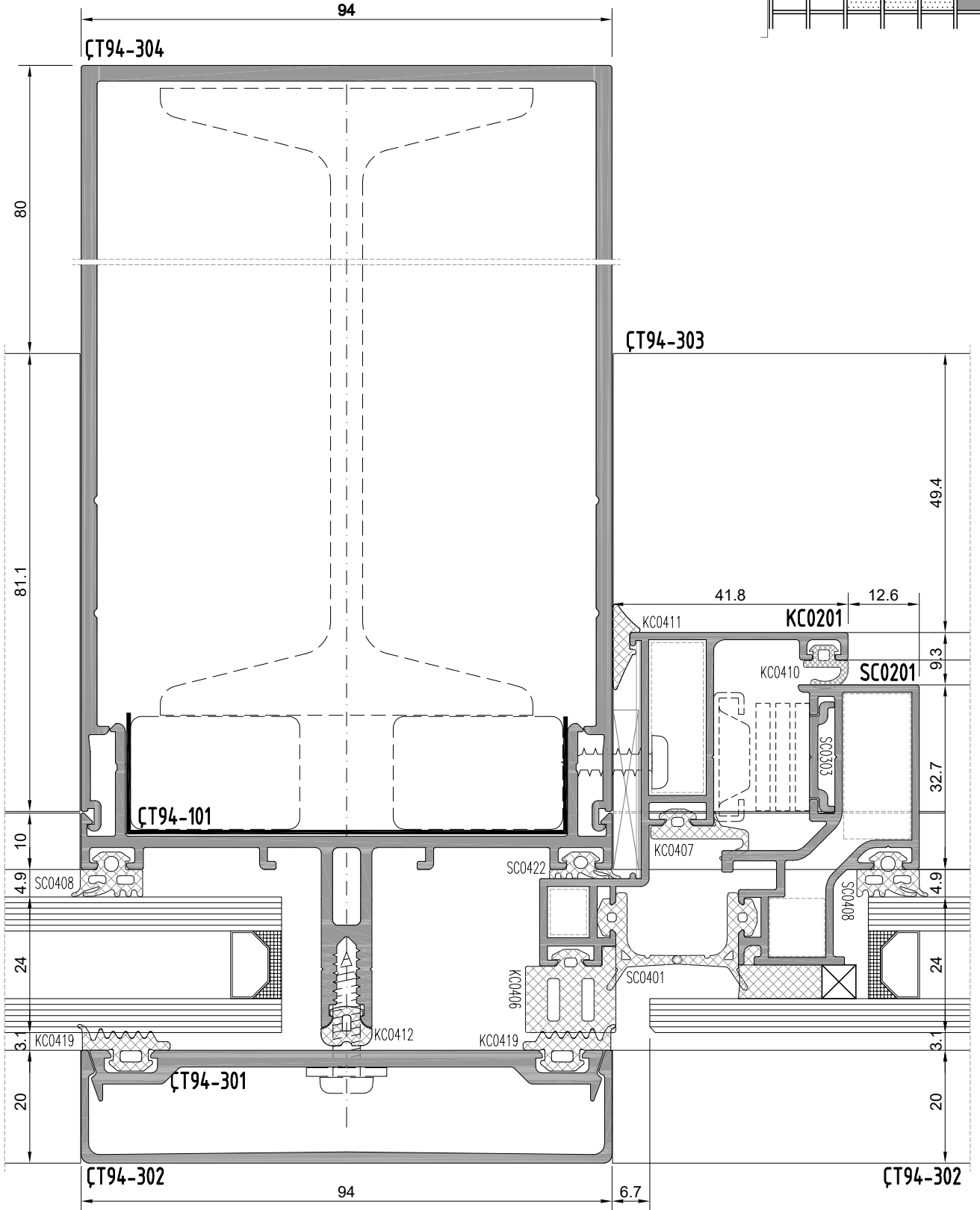
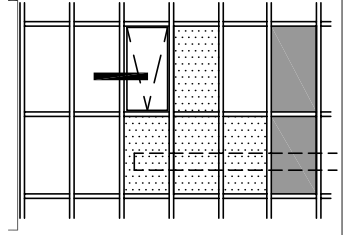



**ÇT94**  
**ÇELİK TAKVİYELİ CEPHE**  
STEEL REINFORCED FAÇADE

**KANAT - SABİT**  
SASH-FIXED

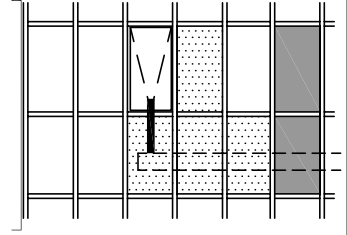

**ÇT94-304**

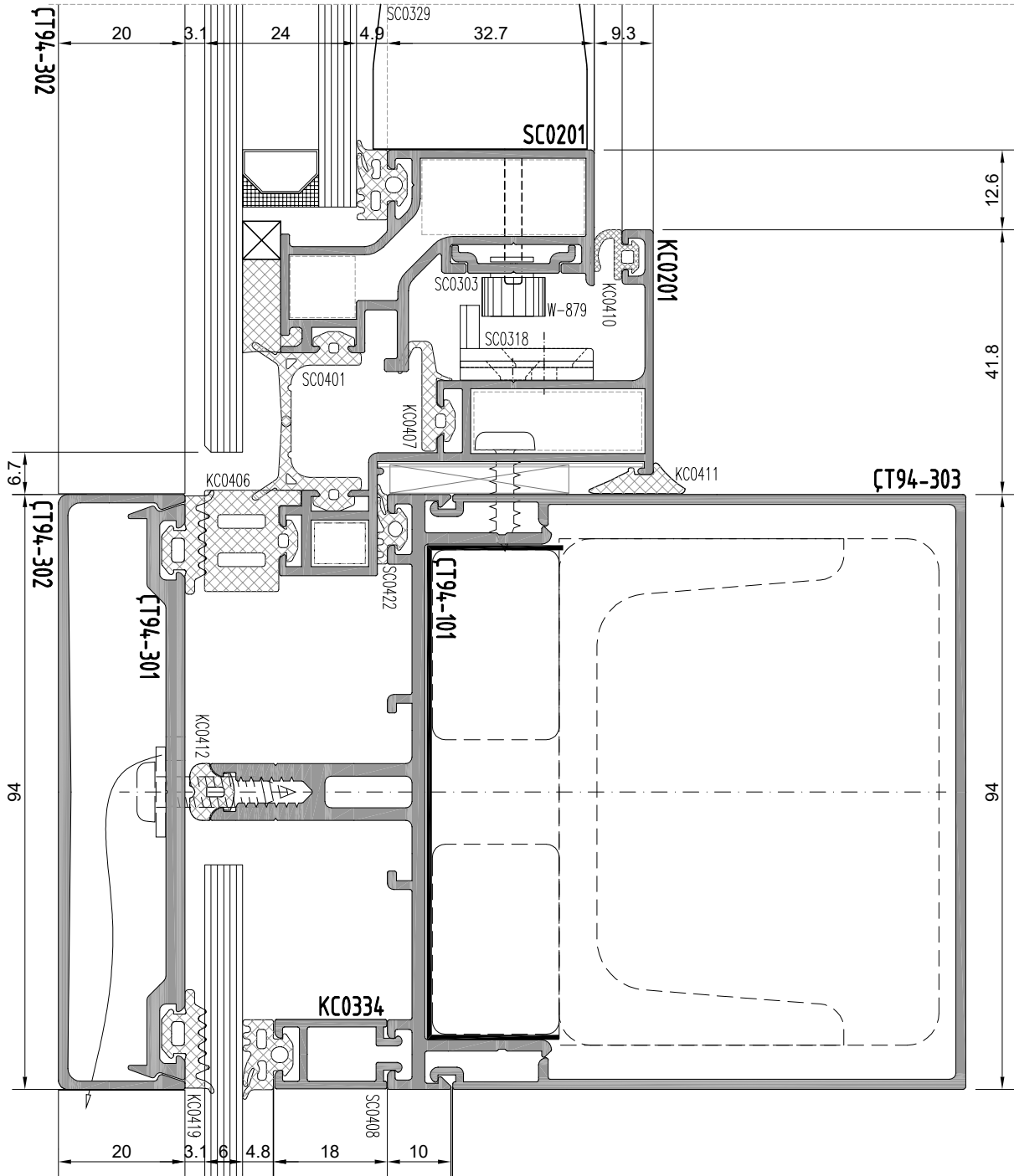

**ÇT94**  
**ÇELİK TAKVİYELİ CEPHE**  
STEEL REINFORCED FAÇADE

**SABİT - SABİT**  
FIXED-FIXED

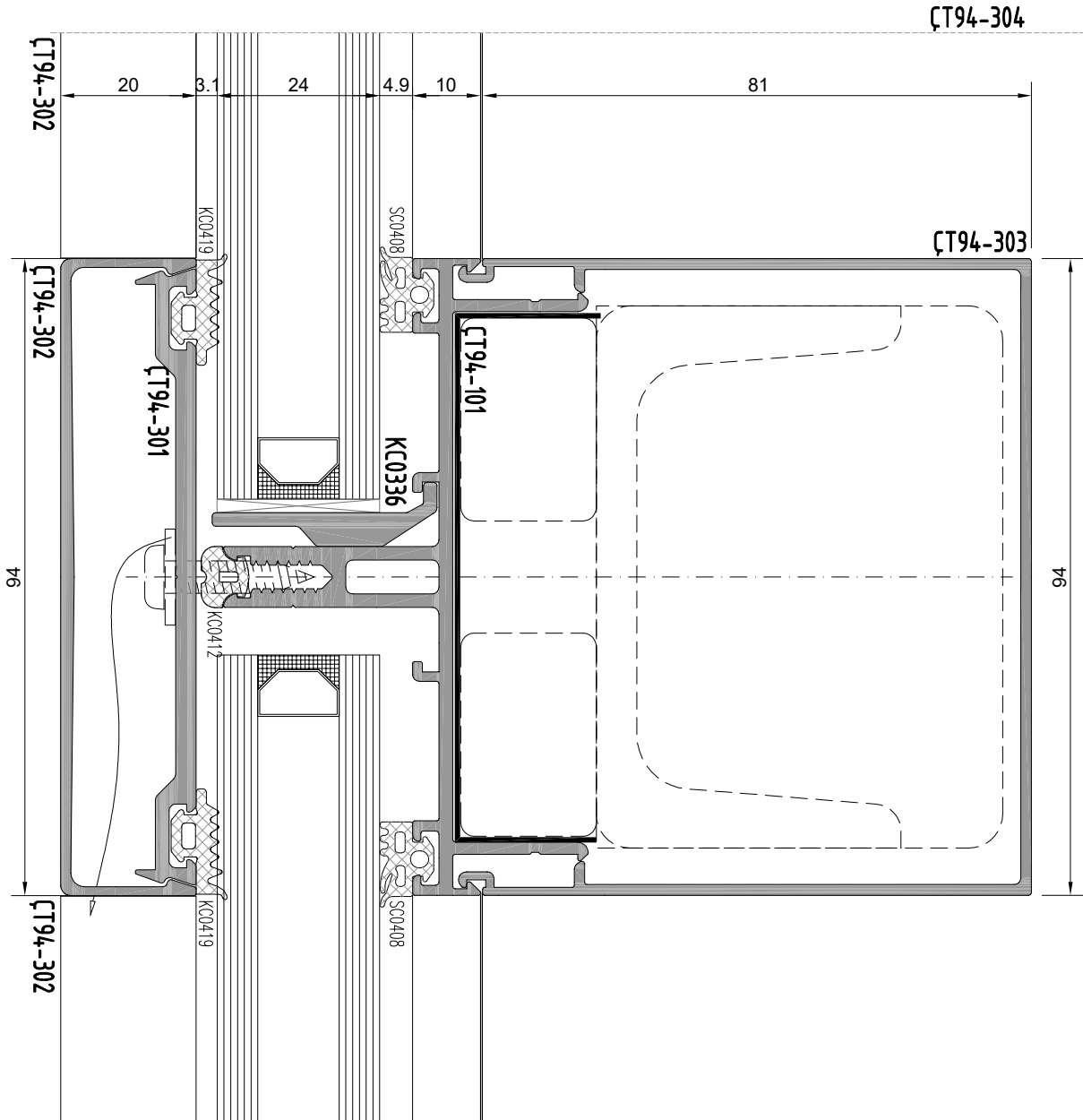
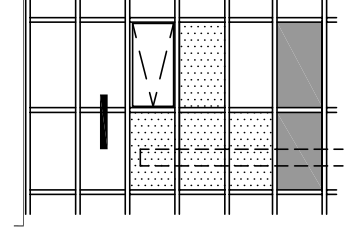



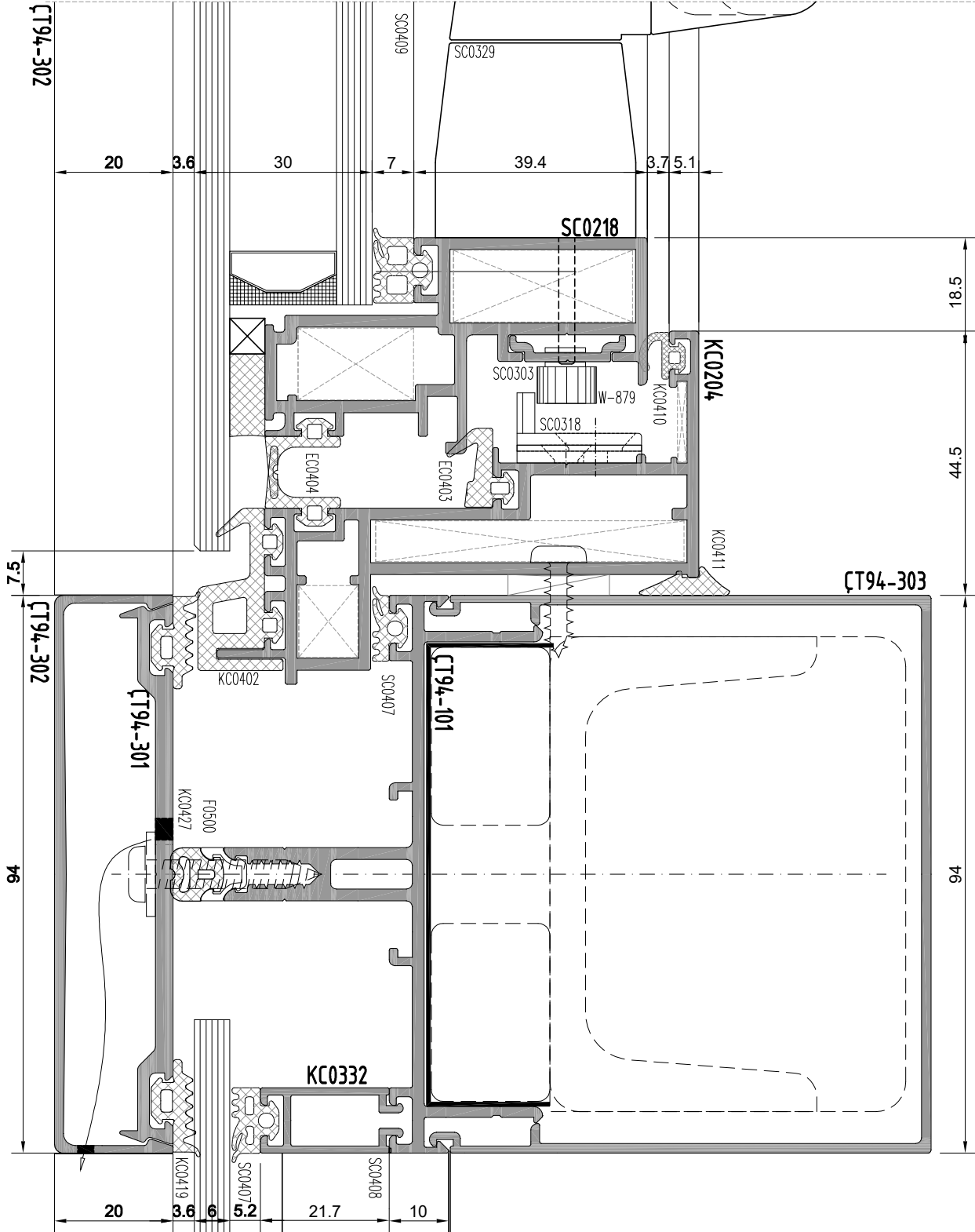
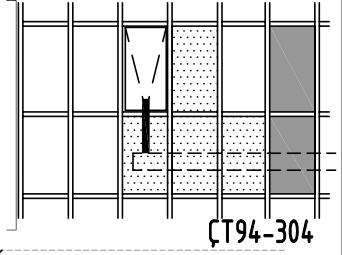

ÇT94  
ÇELİK TAKVİYELİ CEPHE  
STEEL REINFORCED FAÇADE

KANAT - SABİT  
SASH-FIXED

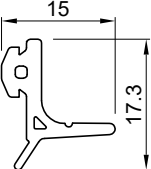
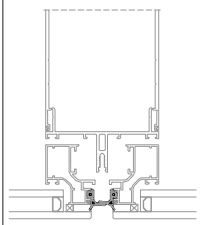
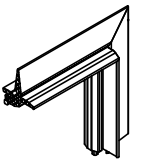
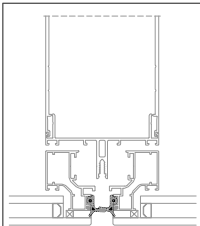
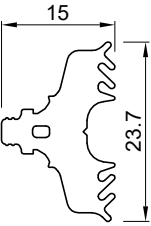
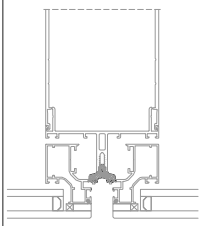

ÇT94  
ÇELİK TAKVİYELİ CEPHE  
STEEL REINFORCED FACADE

Fitil listesi  
Gasket list

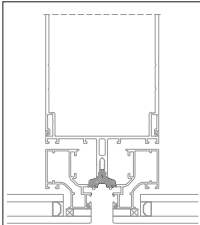
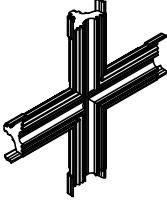
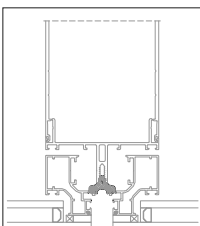
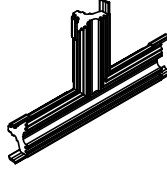
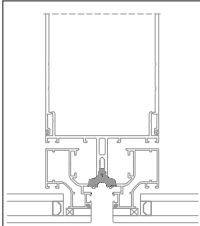
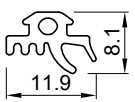
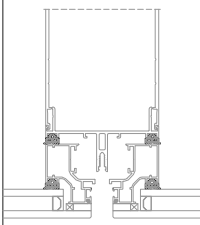
kod code	şekil drawing	tanım description	teorik ağırlık theoretical weight gr / m	paket ağırlığı package weight kg / package	paket metrajı in one package metre / package	kullanım yeri aplication
SC0401		Panel dış fitili Frame gasket	74 gr/m	15 kg	202 m	
SC0402		Panel dış fitili (köşe) Frame gasket (corner)	89 gr\m	-	50 ad-pcs	
SC0403		Taşıyıcı ön fitili Mullion or transom front gasket	173 gr/m	15 kg	87 m	
SC0404		Taşıyıcı ön fitili ( L merkez ) Mullion or transom front gasket (L center)	17,6 gr\m	-	50 ad-pcs	
SC0405		Taşıyıcı ön fitili ( T merkez ) Mullion or transom front gasket (T center)	31,6 gr\m	-	50 ad-pcs	
SC0406		Taşıyıcı ön fitili ( + merkez ) Mullion or transom front gasket (+ center)	24,6 gr\m	-	50 ad-pcs	
SC0422		Taşıyıcı ve Panel iç fitili Mullion-transom or Panel gasket inside	46 gr/m	15 kg	326 m	

**ÇT94**  
**ÇELİK TAKVİYELİ CEPHE**  
STEEL REINFORCED FACADE

**Fitil listesi**  
Gasket list

kod code	şekil drawing	tanım description	teorik ağırlık theoretical weight gr / m	paket ağırlığı package weight kg / package	paket metrajı in one package metre / package	kullanım yeri aplication
SC0407		Taşıyıcı ve Panel iç fitili Mullion-transom or Panel gasket inside	73 gr/m	15 kg	205 m	
SC0408		Taşıyıcı ve Panel iç fitili Mullion-transom or Panel gasket inside	88 gr/m	15 kg	170 m	
SC0409		Taşıyıcı ve Panel iç fitili Mullion-transom or Panel gasket inside	101 gr/m	15 kg	148 m	
SC0410		Taşıyıcı ve Panel iç fitili Mullion-transom or Panel gasket inside	113 gr/m	15 kg	133 m	
SC0411		Taşıyıcı ve Panel iç fitili Mullion-transom or Panel gasket inside	144 gr/m	15 kg	104 m	
SC0420		Taşıyıcı ve Panel iç fitili Mullion-transom or Panel gasket inside	167 gr/m	15 kg	90 m	
SC0421		Taşıyıcı ve Panel iç fitili Mullion-transom or Panel gasket inside	189 gr/m	15 kg	79 m	

**ÇT94**  
**ÇELİK TAKVİYELİ CEPHE**  
STEEL REINFORCED FACADE

**Fitil listesi**  
Gasket list

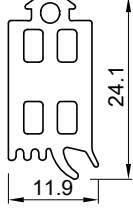
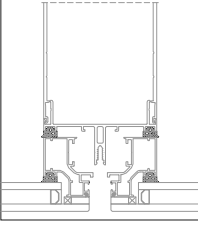
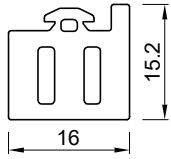
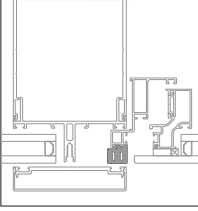
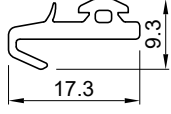
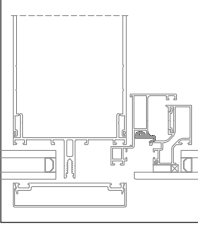
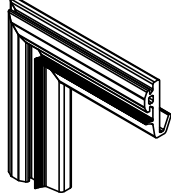
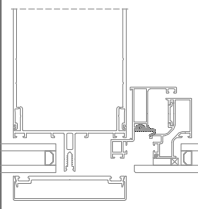
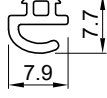
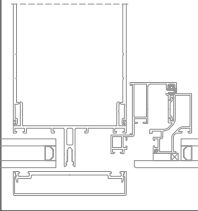
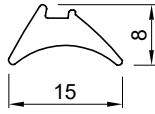
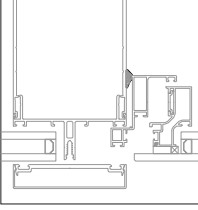
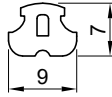
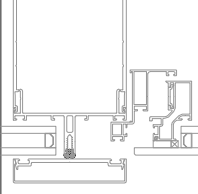
kod code	şekil drawing	tanım description	teorik ağırlık theoretical weight gr / m	paket ağırlığı package weight kg / package	paket metrajı in one package metre / package	kullanım yeri aplication
SC0425		Taşıyıcı ve Panel iç fitili Mullion-transom or Panel gasket inside	217,6 gr/m	15 kg	69 m	
KC0406		Kasa dış fitili Frame gasket	256 gr/m	15 kg	58,5 m	
KC0407		Kasa bini fitili Frame gasket	72,5 gr/m	15 kg	207 m	
KC0408		Kasa bini köşe fitili Frame gasket (corner)	0	0	0 ad-pcs	
KC0410		Kasa çarpma fitili Frame gasket	34 gr/m	15 kg	441 m	
KC0411		Kasa çarpma fitili Frame gasket	64 gr/m	15 kg	234 m	
KC0412		Taşıyıcı ön fitili Mullion-transom gasket front	24,6 gr/m	15 kg	275 m	

ÇT94  
ÇELİK TAKVİYELİ CEPHE  
STEEL REINFORCED FACADE

Fitil listesi  
Gasket list

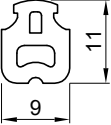
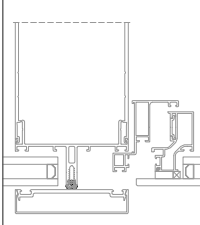
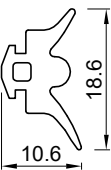
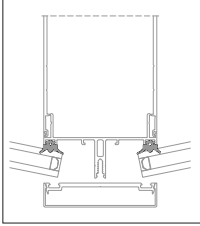
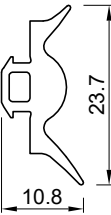
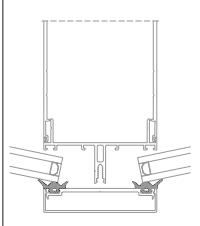
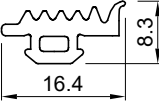
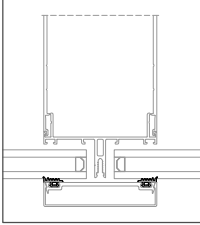
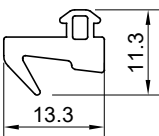
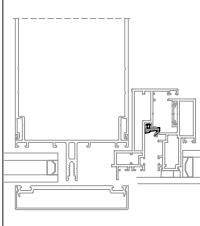
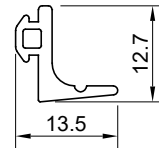
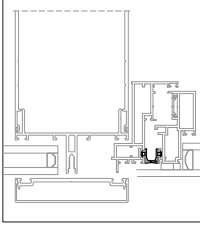
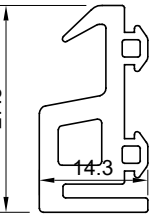
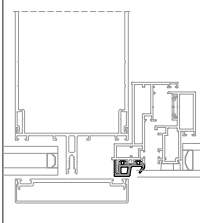
kod code	şekil drawing	tanım description	teorik ağırlık theoretical weight gr / m	paket ağırlığı package weight kg / package	paket metrajı in one package metre / package	kullanım yeri aplication
KC0413		Taşıyıcı ön fitili Mullion-transom gasket front	80 gr/m	15 kg	187,5 m	
KC0415		Açılı köşe fitili Mullion-transom gasket inside	80 gr/m	15 kg	187 m	
KC0417		Açılı köşe fitili Mullion-transom gasket inside	96 gr/m	15 kg	156 m	
KC0419		Baskı profil fitili Glazing gasket	73 gr/m	15 kg	205 m	
EC0403		Kasa bini fitili Frame gasket	59 gr/m	15 kg	254 m	
EC0404		Panel dış fitili Frame gasket	59 gr/m	15 kg	254 m	
KC0402		Kasa dış fitili Frame gasket	302,5 gr/m	15 kg	50 m	

ÇT94  
ÇELİK TAKVİYELİ CEPHE  
STEEL REINFORCED FACADE

Pvc ızalasyon listesi  
Pvc ızalator list

kod code	şekil drawing	tanım description	metraji metre / package	kullanım yeri aplication
F0500		Taşıyıcı ön ızalasyon (pvc) Mullion or transom front ızalator (pvc)	31 m	
F0501		Taşıyıcı ön ızalasyon (pvc) Mullion or transom front ızalator (pvc)	71 m	
F0502		Taşıyıcı ön ızalasyon (pvc) Mullion or transom front ızalator (pvc)	87,5 m	
F0503		Taşıyıcı ön ızalasyon (pvc) Mullion or transom front ızalator (pvc)	95,6 m	
F0504		Taşıyıcı ön ızalasyon (pvc) Mullion or transom front ızalator (pvc)	6 m	
F0505		Taşıyıcı ön ızalasyon (pvc) Mullion or transom front ızalator (pvc)	118 m	
F0506		Taşıyıcı ön ızalasyon (pvc) Mullion or transom front ızalator (pvc)	134 m	

ÇT94  
ÇELİK TAKVİYELİ CEPHE  
STEEL REINFORCED FACADE

Pvc ızalasyon listesi  
Pvc ızalator list

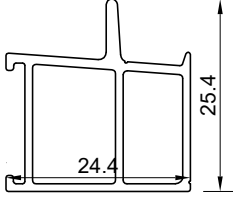
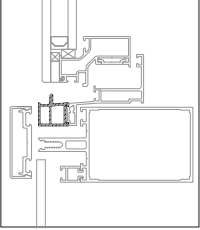
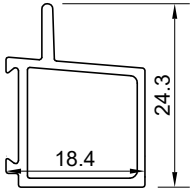
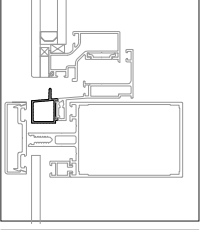
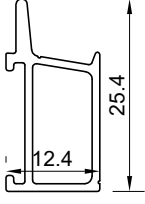
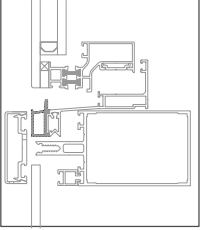
kod code	şekil drawing	tanım description	metraji metre / package	kullanım yeri aplication
F0520		Kasa profili ızalasyon (pvc) Frame profile ızalator (pvc)	170 m	
F0521		Kasa profili ızalasyon (pvc) Frame profile ızalator (pvc)	126 m	
F0522		Kasa profili ızalasyon (pvc) Frame profile ızalator (pvc)	106 m	

# ÇT94 ÇELİK TAKVİYELİ CEPHE STEEL REINFORCED FAÇADE

İMALAT ŞEMASI  
PRODUCTION PLAN

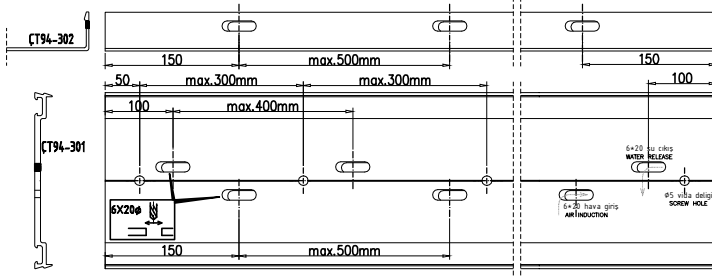
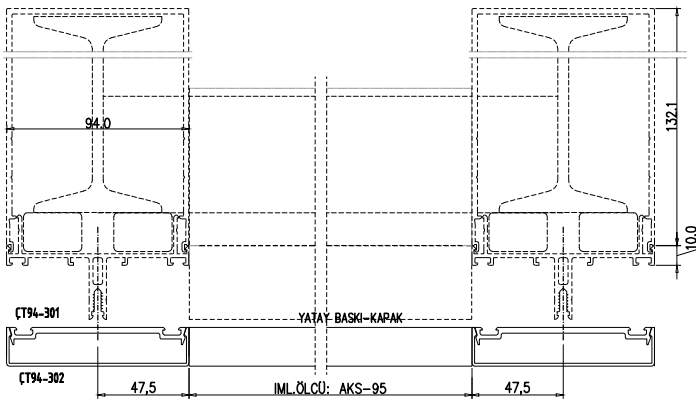
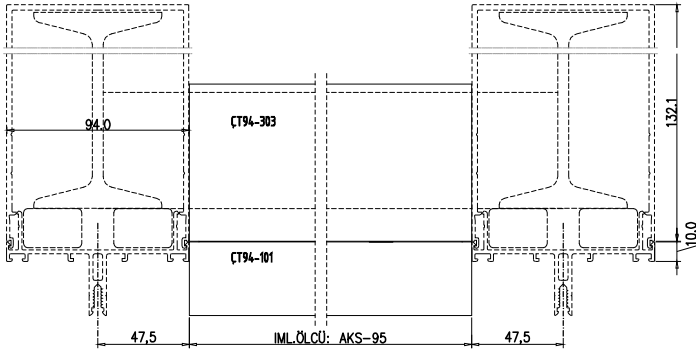
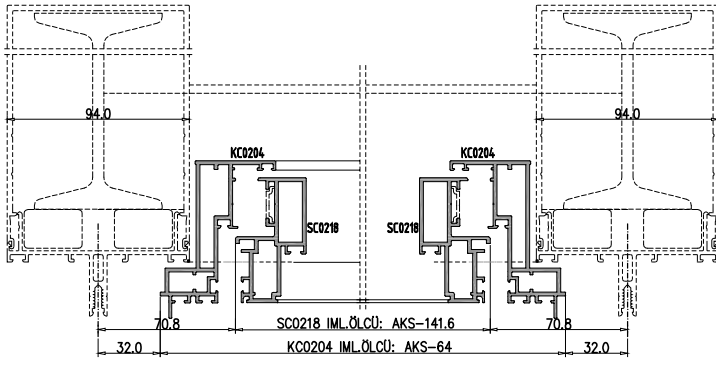
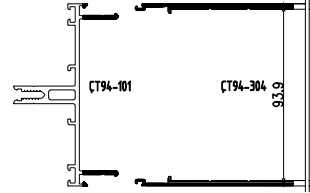
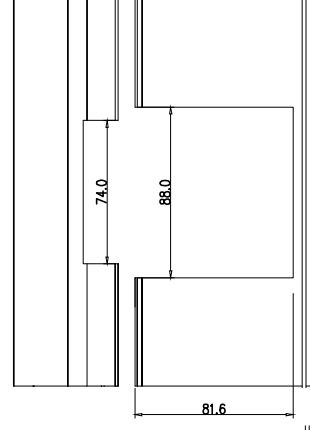
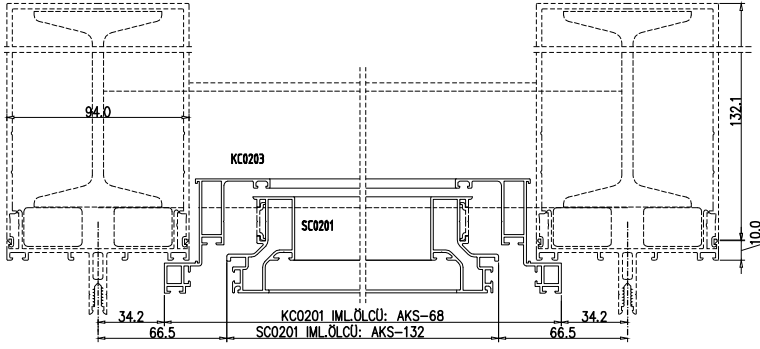



# ÇT94 ÇELİK TAKVİYELİ CEPHE STEEL REINFORCED FAÇADE

AKSESUARLAR  
ACCESSOIRES

PANEL OTURTMA TAKOZU ( PVC )  
SUPPORT FOR PANEL ( PVC )

SC0305 (yerli) (native)

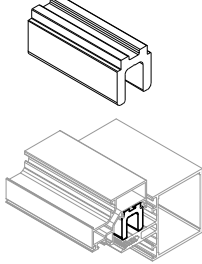

AYARLI PİM KARŞIĞI  
ADJUSTABLE STRIKER FOR WINDOW

SC0318 (ithal) (import)



SC0318-a (yerli) (native)

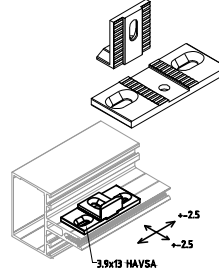

KONDENS PLASTIĞI  
CONDENSAT PLASTIC

SC0345 (yerli) (native)

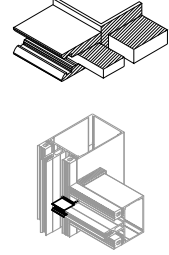

ÇİFT DİLLİ CEPHE KOLU  
FACADE HANDLE

SC0329 (ithal) (import) SC0329-a (yerli) (native) naturel eloksalli (mat anodized)  
SC0330 (ithal) (import) SC0330-a (yerli) (native) pres veya renkli (mill finishand and painted)

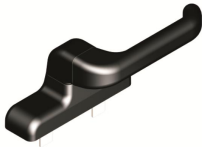

ÇİFT DİLLİ ANAHTARLI CEPHE KOLU  
FACADE HANDLE ( KEY )

SC0333 (ithal) (import) SC0333-a (yerli) (native) naturel eloksalli (mat anodized)  
SC0334 (ithal) (import) SC0334-a (yerli) (native) pres veya renkli (mill finishand and painted)



CEPHE KOLU TİJ BAĞLANTI PABUCU  
CONNECTION BLOCK FOR FACADE HANDLE

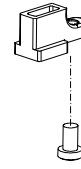

SC0303-a (ithal) (import)  
SC0303-b (yerli) (native)

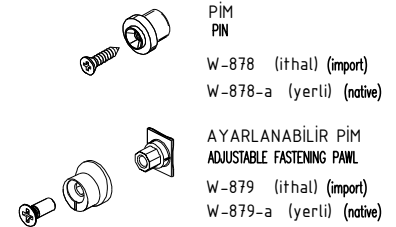
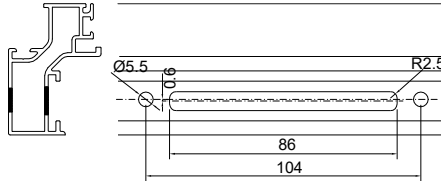
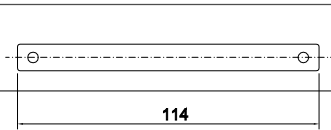
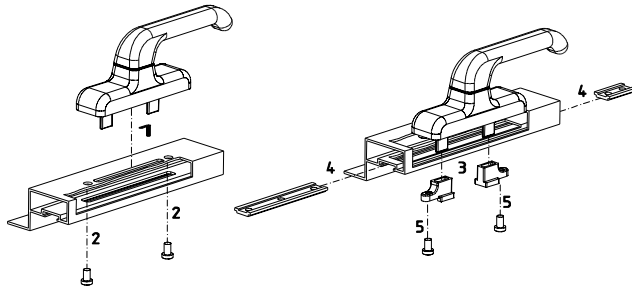
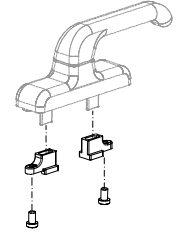

KÖŞE HAREKET AKTARICISI  
MONTION CORNER TRANSMITTER

SC0328 (ithal) (import) SC0328-a (yerli) (native)



TEK DİLLİ CEPHE KOLU  
FACADE HANDLE

SC0331 (ithal) (import) naturel eloksalli (mat anodized)  
SC0331-a (yerli) (import) naturel eloksalli (mat anodized)  
SC0332 (ithal) (native) pres veya renkli (mill finishand and painted)  
SC0332-a (yerli) (native) pres veya renkli (mill finishand and painted)

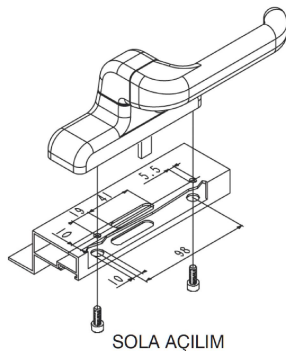
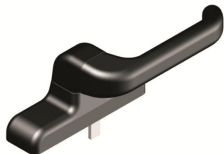

SOLA AÇILIM

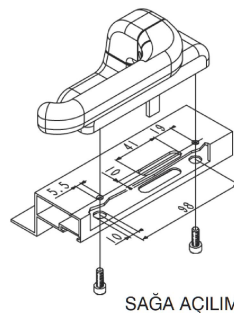

SAĞA AÇILIM

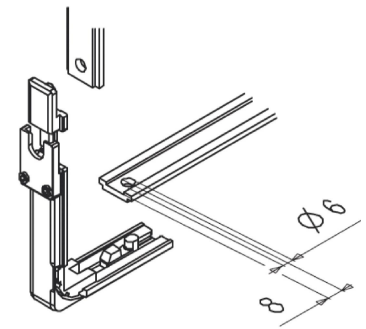

# ÇT94

## ÇELİK TAKVİYELİ CEPHE

### STEEL REINFORCED FAÇADE

AKSESUARLAR  
ACCESSOIRES

YÜKSEKLİĞE VE AĞIRLIĞA GÖRE MAXIMUM KANAT GENİSLİKLERİ  
WIDTH ACCORDING TO THE WEIGHT AND THE HEIGHT

max. en boy ölçüsü

Tablodaki değerler ithal için geçerlidir.  
All values are just for import

(20kg-50kg)

SC0319 (ithal) (import)	h/kg	20 kg	25 kg	30 kg	35 kg	40 kg	45 kg	50 kg	weight mm	en mm
SC0319-a (yerli) (native)	450	1500	1500	1500	1500	1500	1500	1500		
TYPE P - 10"	500	1500	1500	1500	1500	1500	1500	1500	1500	1500
	550	1500	1500	1500	1500	1500	1500	1500	1500	1500
	600	1500	1500	1500	1500	1500	1500	1500	1500	1400
	650	1500	1500	1500	1500	1500	1500	1400	1292	
	700	1500	1500	1500	1500	1400	1300	1200		
	750	1500	1500	1500	1400	1307	1213	1120		
	w = 23 mm l = 2615 mm degree of opening 35°									

(80kg-135kg)

SC0324 (ithal) (import)	h/kg	80 kg	90 kg	100 kg	110 kg	120 kg	130 kg	135 kg	weight mm	en mm	
SC0324-a (yerli) (native)	700	1875	1875	1875	1875	1875	1875	1875			1875
TYPE P - 20"	800	1875	1875	1875	1875	1875	1875	1875	1875	1875	
	900	1875	1875	1875	1875	1875	1875	1875	1875	1875	
	1000	1875	1875	1875	1875	1875	1875	1875	1875	1875	
	1100	1875	1875	1875	1875	1875	1875	1875	1875	1875	
	1200	1875	1875	1875	1875	1875	1875	1875	1875	1875	
	1300	1875	1875	1875	1875	1875	1875	1875	1846		
	1400	1875	1875	1875	1875	1875	1789	1714			
	1500	1875	1875	1875	1875	1810	1566	1600			
	1600	1875	1875	1875	1829	1697	1875	1500			
	1700	1875	1875	1845	1721	1597	1474	1412			
	w = 23 mm l = 5115 mm degree of opening 25°										

(30kg-60kg)

SC0320 (ithal) (import)	h/kg	30 kg	35 kg	40 kg	45 kg	50 kg	55 kg	60 kg	weight mm	en mm
SC0320-a (yerli) (native)	500	1500	1500	1500	1500	1500	1500	1500		
TYPE P - 12"	550	1500	1500	1500	1500	1500	1500	1500	1500	1500
	600	1500	1500	1500	1500	1500	1500	1500	1500	1500
	650	1500	1500	1500	1500	1500	1500	1477		
	700	1500	1500	1500	1500	1500	1472	1371		
	750	1500	1500	1500	1500	1467	1373	1280		
	800	1500	1500	1500	1463	1375	1288	1200		
	850	1500	1500	1459	1400	1294	1212	1129		
	w = 23 mm l = 3175 mm degree of opening 35°									

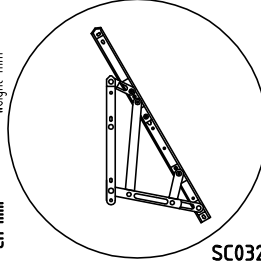

(35kg-69,5kg)

SC0321 (ithal) (import)	h/kg	35 kg	40 kg	45 kg	50 kg	55 kg	60 kg	65 kg	69 kg	weight mm	en mm
SC0321-a (yerli) (native)	550	1625	1625	1625	1625	1625	1625	1625	1625		
TYPE P - 14"	600	1625	1625	1625	1625	1625	1625	1625	1625	1625	1625
	650	1625	1625	1625	1625	1625	1625	1625	1625	1625	1625
	700	1625	1625	1625	1625	1625	1625	1625	1625	1625	1625
	750	1625	1625	1625	1625	1625	1625	1625	1625	1625	1625
	800	1625	1625	1625	1625	1625	1625	1625	1625	1625	1625
	850	1625	1625	1625	1625	1625	1625	1604	1529		
	900	1625	1625	1625	1625	1625	1604	1514	1444		
	950	1625	1625	1625	1625	1582	1514	1435	1368		
	1000	1625	1625	1625	1573	1503	1625	1363	1300		
	1050	1625	1625	1565	1498	1432	1625	1298	1238		
	w = 23 mm l = 3535 mm degree of opening 35°										

(90kg-137kg)

SC0325 (ithal) (import)	h/kg	90 kg	100 kg	110 kg	120 kg	130 kg	137 kg	weight mm	en mm	
SC0325-a (yerli) (native)	750	1875	1875	1875	1875	1875	1875			1875
TYPE P - 22"	900	1875	1875	1875	1875	1875	1875	1875	1875	
	1000	1875	1875	1875	1875	1875	1875	1875	1875	
	1100	1875	1875	1875	1875	1875	1875	1875	1875	
	1200	1875	1875	1875	1875	1875	1875	1875	1875	
	1300	1875	1875	1875	1875	1875	1875	1875	1875	
	1400	1875	1875	1875	1875	1875	1798	1821		
	1500	1875	1875	1875	1875	1875	1798	1700		
	1600	1875	1875	1875	1875	1817	1686	1594		
	1700	1875	1875	1834	1710	1587	1500			
	1800	1875	1875	1734	1610	1498	1417			
w = 23 mm l = 5565 mm degree of opening 25°										

(45kg-88,5kg)

SC0322 (ithal) (import)	h/kg	45 kg	50 kg	55 kg	60 kg	65 kg	70 kg	75 kg	80 kg	85 kg	88,5kg	weight mm	en mm	
SC0322-a (yerli) (native)	600	1750	1750	1750	1750	1750	1750	1750	1750	1750	1750			1750
TYPE P - 16"	650	1750	1750	1750	1750	1750	1750	1750	1750	1750	1750	1750	1750	
	700	1750	1750	1750	1750	1750	1750	1750	1750	1750	1750	1750	1750	
	750	1750	1750	1750	1750	1750	1750	1750	1750	1750	1750	1750	1750	
	800	1750	1750	1750	1750	1750	1750	1750	1750	1750	1750	1750	1750	
	850	1750	1750	1750	1750	1750	1750	1750	1750	1750	1750	1750	1750	
	900	1750	1750	1750	1750	1750	1750	1750	1750	1750	1750	1750	1750	
	950	1750	1750	1750	1750	1750	1750	1750	1750	1750	1750	1750	1750	
	1000	1750	1750	1750	1750	1750	1750	1750	1750	1750	1739	1680		
	1050	1750	1750	1750	1750	1750	1750	1750	1738	1657	1600			
	1100	1750	1750	1750	1750	1750	1750	1736	1659	1581	1527			
	1150	1750	1750	1750	1750	1750	1734	1660	1586	1513	1461			
	1200	1750	1750	1750	1750	1733	1662	1591	1520	1450	1400			
	1250	1750	1750	1750	1731	1663	1595	1528	1460	1392	1344			
	1300	1750	1750	1730	1665	1560	1534	1470	1403	1338	1292			
	w = 23 mm l = 4145 mm degree of opening 30°													

(90kg-137kg)

SC0326 (ithal) (import)	h/kg	90 kg	100 kg	110 kg	120 kg	130 kg	139 kg	weight mm	en mm	
SC0326-a (yerli) (native)	800	1875	1875	1875	1875	1875	1875			1875
TYPE P - 24"	950	1875	1875	1875	1875	1875	1875	1875	1875	
	1100	1875	1875	1875	1875	1875	1875	1875	1875	
	1200	1875	1875	1875	1875	1875	1875	1875	1875	
	1300	1875	1875	1875	1875	1875	1875	1875	1875	
	1400	1875	1875	1875	1875	1875	1875	1875	1875	
	1500	1875	1875	1875	1875	1875	1875	1800		
	1600	1875	1875	1875	1875	1875	1806	1688		
	1700	1875	1875	1875	1823	1700	1588			
	1800	1875	1875	1839	1722	1605	1500			
	1900	1875	1875	1742	1631	1521	1421			
	w = 23 mm l = 6025 mm degree of opening 25°									

(55kg-102kg)

SC0323 (ithal) (import)	h/kg	55 kg	60 kg	65 kg	70 kg	75 kg	80 kg	85 kg	90 kg	95 kg	102 kg	weight mm	en mm
SC0323-a (yerli) (native)	650	1750	1750	1750	1750	1750	1750	1750	1750	1750	1750		
TYPE P - 18"	750	1750	1750	1750	1750	1750	1750	1750	1750	1750	1750	1750	1750
	850	1750	1750	1750	1750	1750	1750	1750	1750	1750	1750	1750	1750
	950	1750	1750	1750	1750	1750	1750	1750	1750	1750	1750	1750	1750
	850	1750	1750	1750	1750	1750	1750	1750	1750	1750	1750	1750	1750
	1050	1750	1750	1750	1750	1750	1750	1750	1750	1750	1704		
	1150	1750	1750	1750	1750	1750	1750	1750	1731	1663	1568		
	1250	1750	1750	1750	1750	1750	1729	1666	1603	1540	1452		
	1350	1750	1750	1750	1750	1728	1667	1606	1546	1485	1400		
	1450	1750	1750	1750	1727	1668	1610	1551	1492	1434	1352		
	1500	1750	1750	1750									

**ÇT94**  
**ÇELİK TAKVİYELİ CEPHE**  
**STEEL REINFORCED FAÇADE**

**AKSESUARLAR**  
ACCESSOIRES

DALDIRMA GALVENİZLİ SABİT U ANKRAJ ( YATAY BAKLALI )  
DIP GALVANIZED FIX "U" ANCHOR ( HORIZONTAL )

SC0338-2 (yerli) (native) L= 80 mm  
SC0339-2 (yerli) (native) L= 100 mm  
SC0340-2 (yerli) (native) L= 120 mm  
SC0341-2 (yerli) (native) L= 150 mm  
SC0342-2 (yerli) (native) L= 200 mm

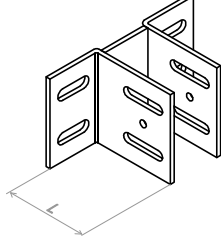

DALDIRMA GALVENİZLİ SABİT U ANKRAJ ( DÜŞEY BAKLALI )  
DIP GALVANIZED FIX "U" ANCHOR ( VERTICAL )

SC0338-1 (yerli) (native) L= 80 mm  
SC0339-1 (yerli) (native) L= 100 mm  
SC0340-1 (yerli) (native) L= 120 mm  
SC0341-1 (yerli) (native) L= 150 mm  
SC0342-1 (yerli) (native) L= 200 mm

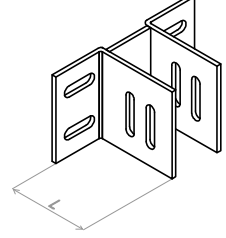

TAŞIYICI DİLATASYON PLASTİĞİ  
DILATATION PLASTIC FOR MULLION

EC0303 (yerli) (native)

