

OB4 - 45 - CAM-CAMA OFIS BOLME

OB4-45 - GLASS TO GLASS PARTITION

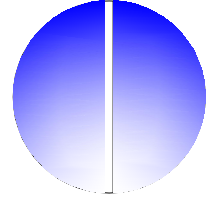
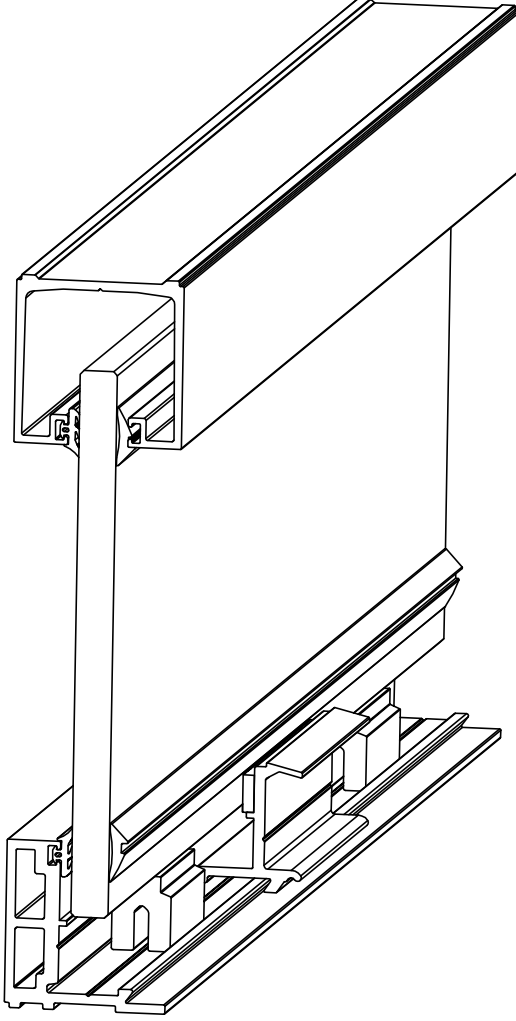
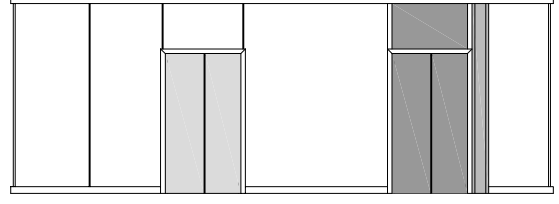
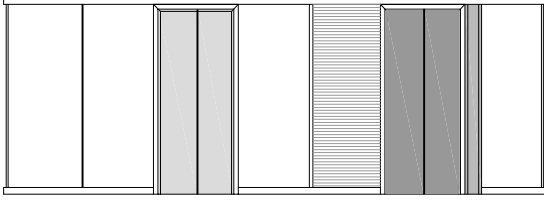

alutech
part

OB4-45

CAM - CAMA BÖLME

GLASS TO GLASS PARTITION

Alaşım Özellikleri

Alloy Properties

EN AW 6060 (AlMgSi0,5 F22) EN AW 6063(AlMg0,7Si F22)

Üretim ve Mekanik Standartları

Production and Mechanical Standards

EN 12020-2 - EN 755-9 - EN 755-2





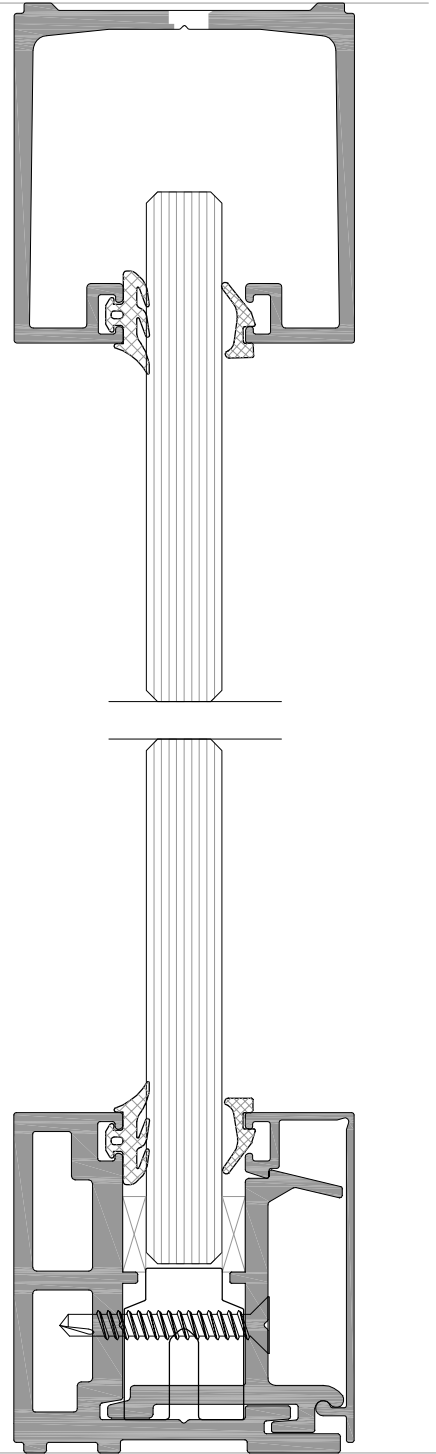
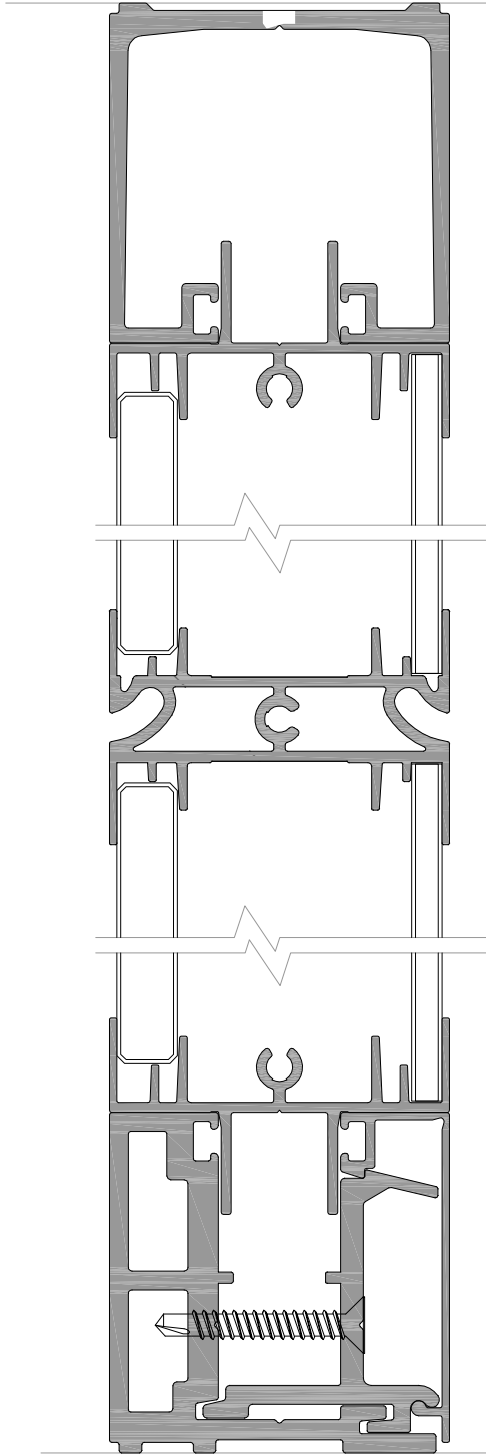
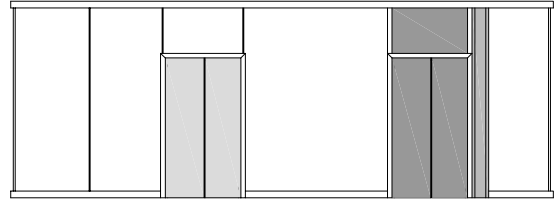
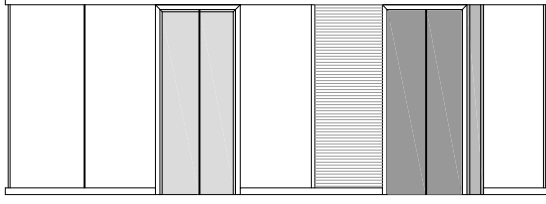

OB4 - 45
CAM CAMA BÖLME
GLASS TO GLASS PARTITION

STANDART PANEL TIPLERİ
STANDARD PANEL TYPES



OB4 - 45
CAM CAMA BÖLME
GLASS TO GLASS PARTITION

ÜRÜN TEKNİK ÖZELLİKLERİ
PRODUCT'S TECHNICAL FEATURES

PROFİL KESİTİ PROFILE VIEW	PROFİL NO PROFILE NO	PROFİL AÇIKLAMASI PROFILE DESCRIPTION	gr/m	PROFİL KESİTİ PROFILE VIEW	PROFİL NO PROFILE NO	PROFİL AÇIKLAMASI PROFILE DESCRIPTION	gr/m
	OB4-101 (45 - 45)	TAVAN PROFİLİ ROOF PROFILE	1064		OB4-111 (45 - 110)	KABLO KANAL PROFİLİ CABLE CHANNEL PROFILE	1787
	OB4-102 (45 - 43.2)	YAN DUVAR ve ZEMİN PROFİLİ SIDE WALLS AND FLOORS PROFILE	1239		OB4-112 (16.2 - 72)	KABLO KANAL KAPAK PROFİLİ CABLE CHANNELS COVER PROFILE	406
	OB4-103 (32.8 - 31.2)	MONTAJ PROFİLİ ASSEMBLY PROFILE	533		OB4-113 (10.3 - 6.1)	CAMDAN CAMA GEÇİŞ PROFİLİ GLASS TO GLASS TRANSITION TO PROFILE	90
	OB4-104 (43.6 - 14.4)	CAM ÇITA PROFİLİ GLASS LATH PROFILE	212		OB4-114 (13.2 - 13.2) (9.71 mm)	CAMDAN CAMA GEÇİŞ PROFİLİ 90° GLASS TO GLASS TRANSITION TO PROFILE	262
	OB4-105 (45 - 45)	CAM PANELDEN KAPI KASA GEÇİŞ PROFİLİ ACCESS PANEL GLASS DOOR FRAME PROFILE FROM	1026		OB4-115 (12.5 - 12.5)	CAMDAN CAMA GEÇİŞ PROFİLİ 135° GLASS TO GLASS TRANSITION TO PROFILE	171
	OB4-106 (45 - 60)	AHŞAP PANELDEN KAPI KASA GEÇİŞ PROFİLİ TRANSITION FROM WOOD PANEL DOOR FRAME PROFILE	1153		OB4-116 (14.6 - 10.3)	CAMDAN CAMA "T" GEÇİŞ PROFİLİ GLASS TO GLASS TRANSITION TO PROFILE	169
	OB4-107 (45 - 44)	CAM PANELDEN AHŞAP PANELE GEÇİŞ PROFİLİ TRANSFER WINDOW PANELS FROM WOOD PANEL PROFILE	750		OB1-202 (36 - 50)	RAF ASKI PROFİLİ RACK HANGER PROFILE	666
	OB4-108 (45 - 21.7)	AHŞAP PANEL YAN PROFİLİ WOOD PANEL SIDE PROFILE	452		OB1-203 (36 - 50)	DOLAP ASKI PROFİLİ HANGING CABINET PROFILE	798
	OB4-109 (31 - 45)	ASKI ASMA PROFİLİ PROFILE TO HANG AS	862				
	OB4-110 (23.5 - 45)	AHŞAP PANEL ÜST VE ALT PROFİLİ WOOD PANEL UPPER AND LOWER PROFILE	316				

Profil değerleri teoriktir. Ağırlık olarak testimde yapılan tartım geçerlidir.
Profil imalatları TS EN 12020-2 ve TS EN 755-9 toleransı,
Moment değerleri EN 14024'e göre hesaplanmıştır.

Profile values are theoretical pre-shipment weight will be valid.
The tolerances of Profile manufacturing are calculated according to EN 12020-2
and TS EN 755-9; moment values are calculated according to EN 14024.

OB4 - 45
CAM CAMA BÖLME
GLASS TO GLASS PARTITION

ÜRÜN TEKNİK ÖZELLİKLERİ
PRODUCT'S TECHNICAL FEATURES

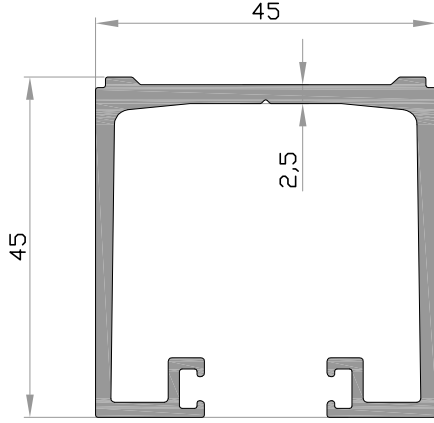

Profil No: OB4-101
Ağırlık : 1064 gr/m

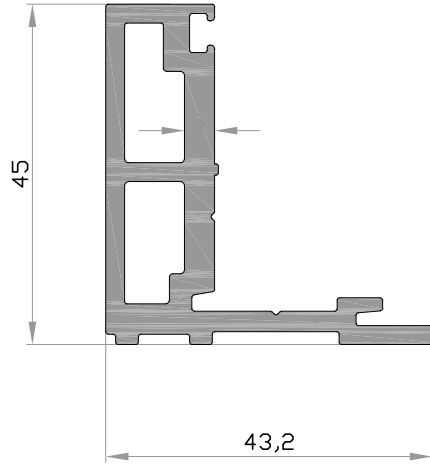

Profil No: OB4-102
Ağırlık : 1239 gr/m

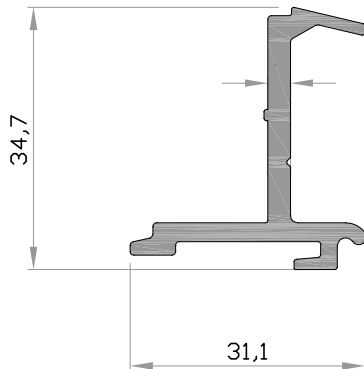

Profil No: OB4-103
Ağırlık : 533 gr/m

OB4 - 45
CAM CAMA BÖLME
GLASS TO GLASS PARTITION

ÜRÜN TEKNİK ÖZELLİKLERİ
PRODUCT'S TECHNICAL FEATURES

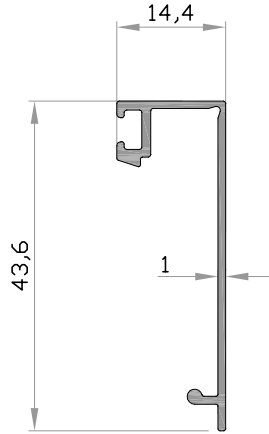

Profil No: OB4-104
Ağırlık : 212 gr/m

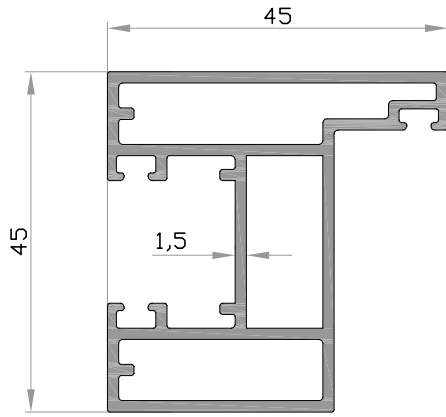

SC0307-k

Profil No: OB4-105
Ağırlık : 1026 gr/m

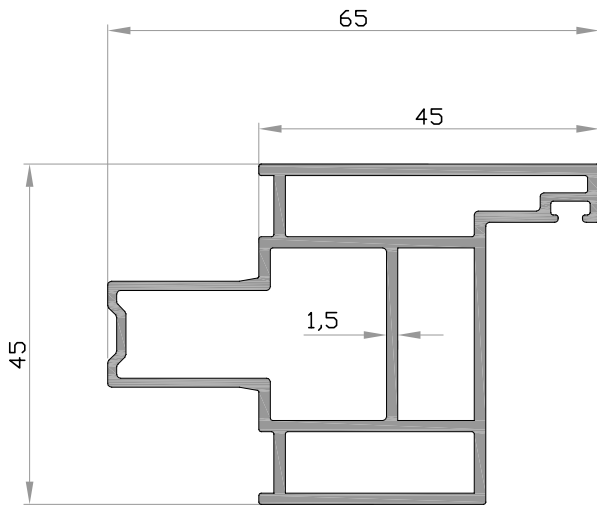

SC0307-k

Profil No: OB4-106
Ağırlık : 1153 gr/m

OB4 - 45
CAM CAMA BÖLME
GLASS TO GLASS PARTITION

ÜRÜN TEKNİK ÖZELLİKLERİ
PRODUCT'S TECHNICAL FEATURES

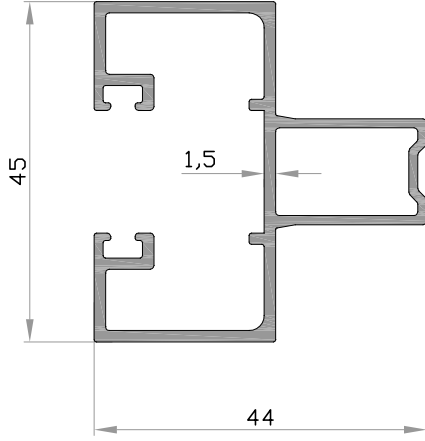

Profil No: OB4-107
Ağırlık : 750 gr/m

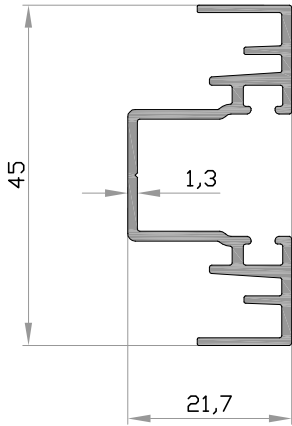

Profil No: OB4-108
Ağırlık : 452 gr/m

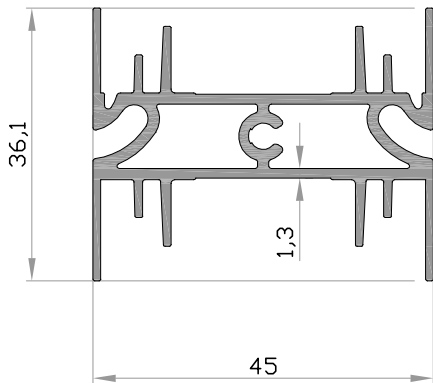

Profil No: OB4-109
Ağırlık : 862 gr/m

OB4 - 45
CAM CAMA BÖLME
GLASS TO GLASS PARTITION

ÜRÜN TEKNİK ÖZELLİKLERİ
PRODUCT'S TECHNICAL FEATURES

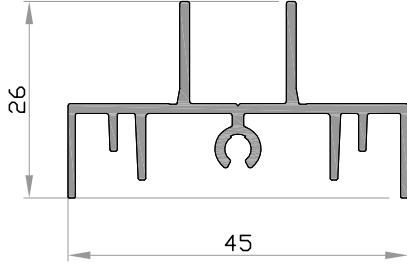

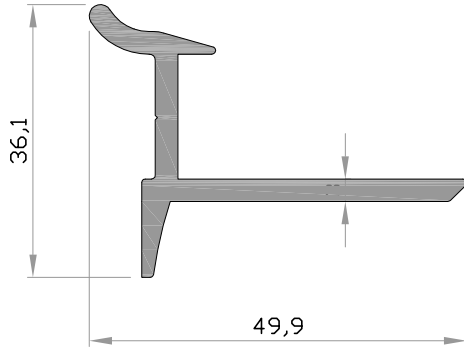

Profil No: OB4-110
Ağırlık : 316 gr/m

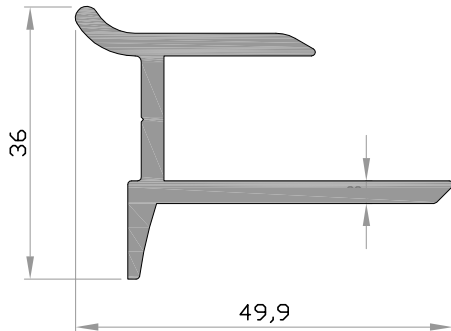

Profil No: OB1-202
Ağırlık : 666 gr/m



Profil No: OB1-203 
Ağırlık : 798 gr/m
 İşaretili profil için satış temsilcinizden bilgi alınır.

OB4 - 45
CAM CAMA BÖLME
GLASS TO GLASS PARTITION

ÜRÜN TEKNİK ÖZELLİKLERİ
PRODUCT'S TECHNICAL FEATURES

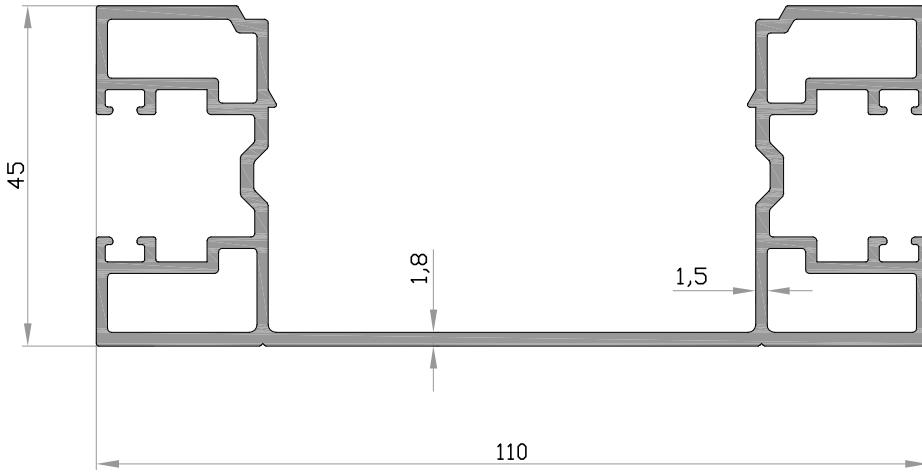

Profil No : OB4-111
Ağırlık : 1787 gr/m

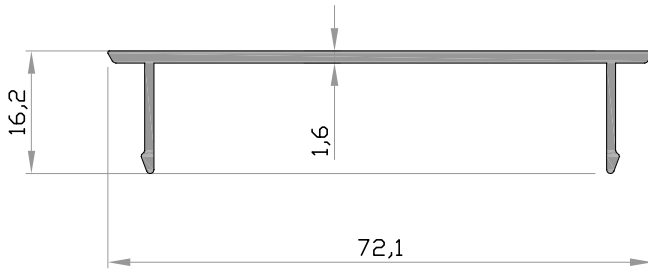

Profil No : OB4-112
Ağırlık : 406 gr/m

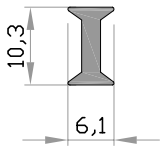

Profil No : OB4-113
Ağırlık : 90 gr/m

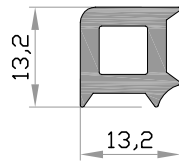

Profil No : OB4-114
Ağırlık : 262 gr/m

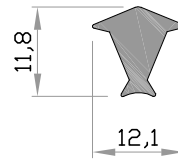

Profil No : OB4-115
Ağırlık : 171 gr/m

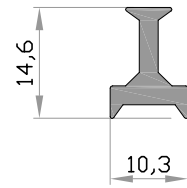

Profil No : OB4-116
Ağırlık : 169 gr/m

0B4 - 45
CAM CAMA BÖLME
GLASS TO GLASS PARTITION

ÜRÜN TEKNİK ÖZELLİKLERİ
PRODUCT'S TECHNICAL FEATURES

SC0307-k	22.4 mm	100 adet/pcs
----------	---------	--------------

Profil No: SC0307
Ağırlık : 1737 gr/m

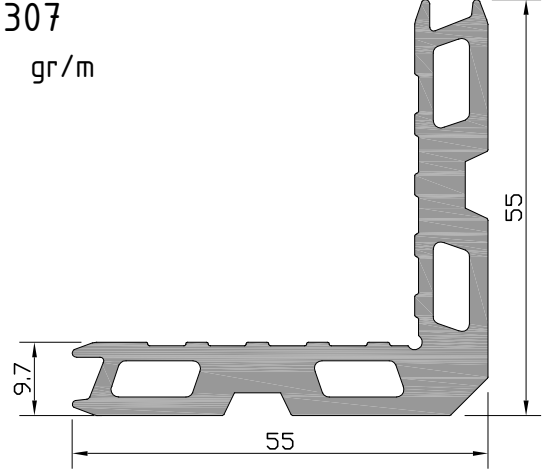

OB4 - 45
CAM CAMA BÖLME
GLASS TO GLASS PARTITION

TAVA, DUVAR BİTİM
.....

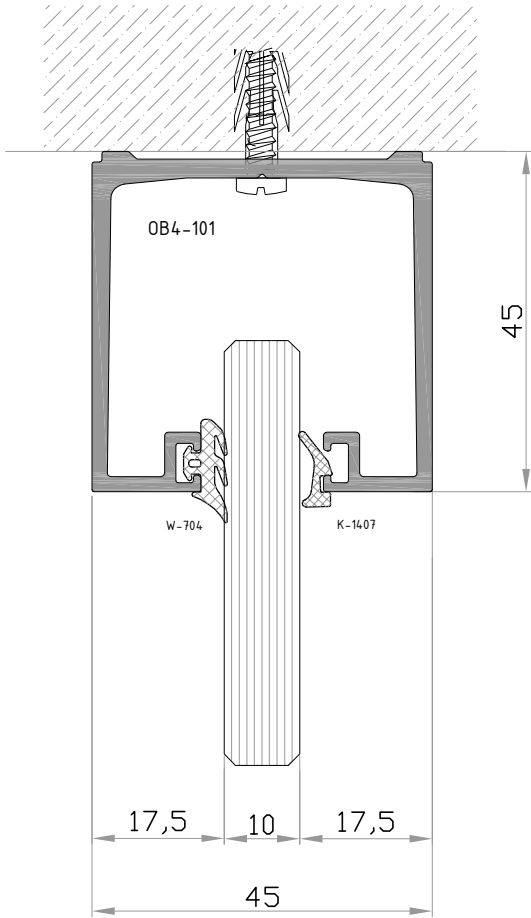
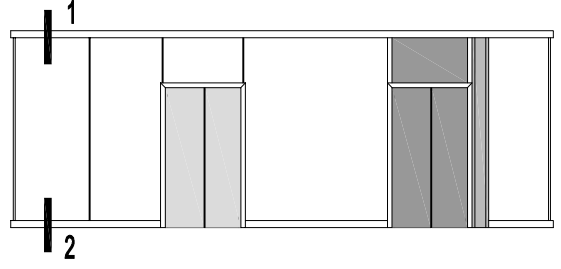
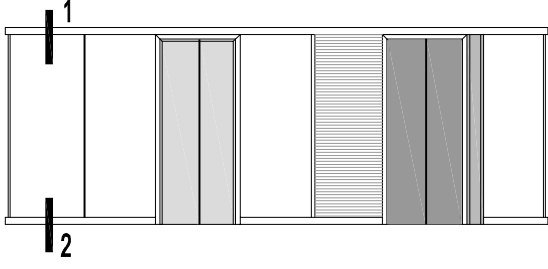

DETAY-1

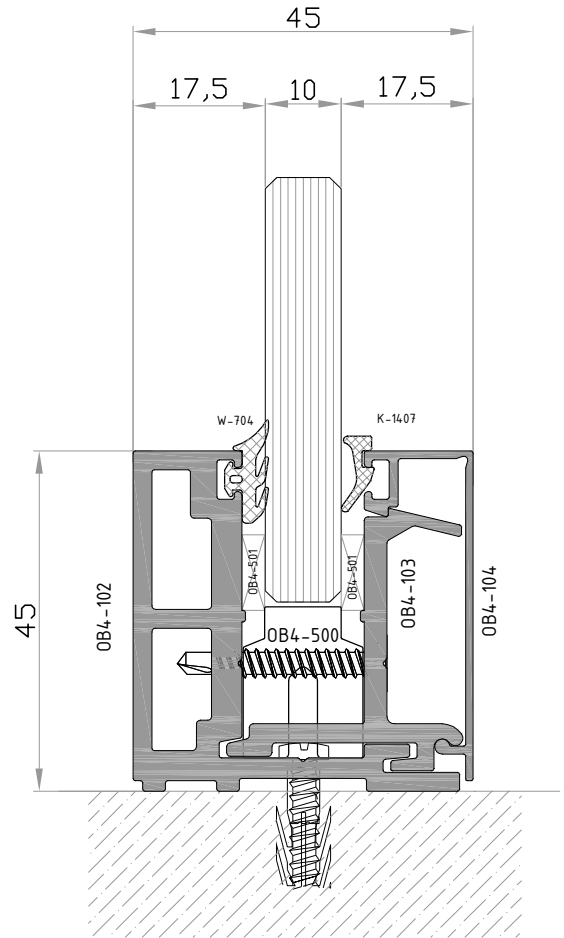

DETAY-2

OB4 - 45
CAM CAMA BÖLME
GLASS TO GLASS PARTITION

CAMDAN CAMA GEÇİŞLER.
.....

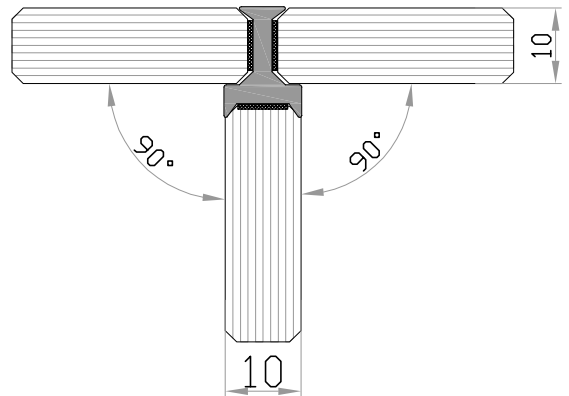
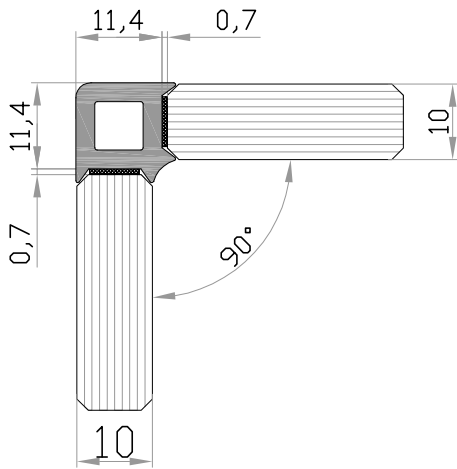
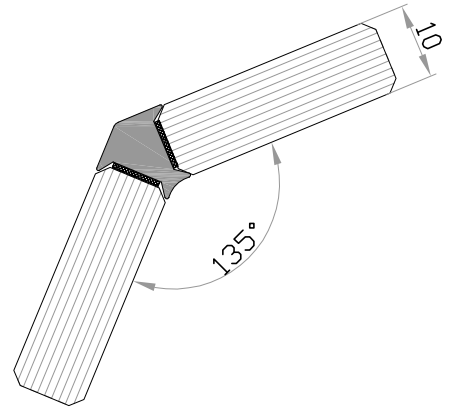
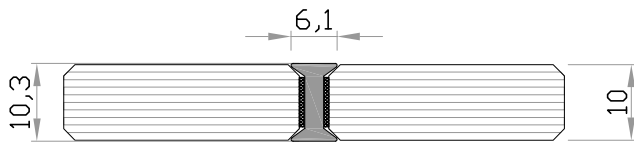
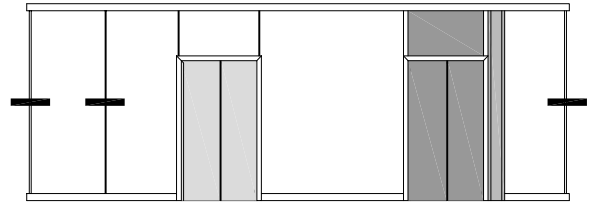
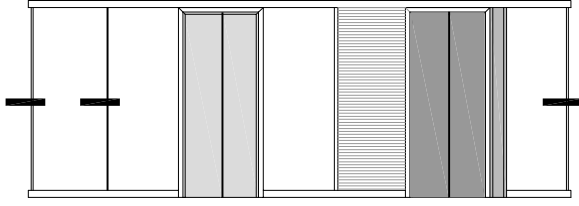

OB4 - 45
CAM CAMA BÖLME
GLASS TO GLASS PARTITION

CAM KAPI VE KASA
.....

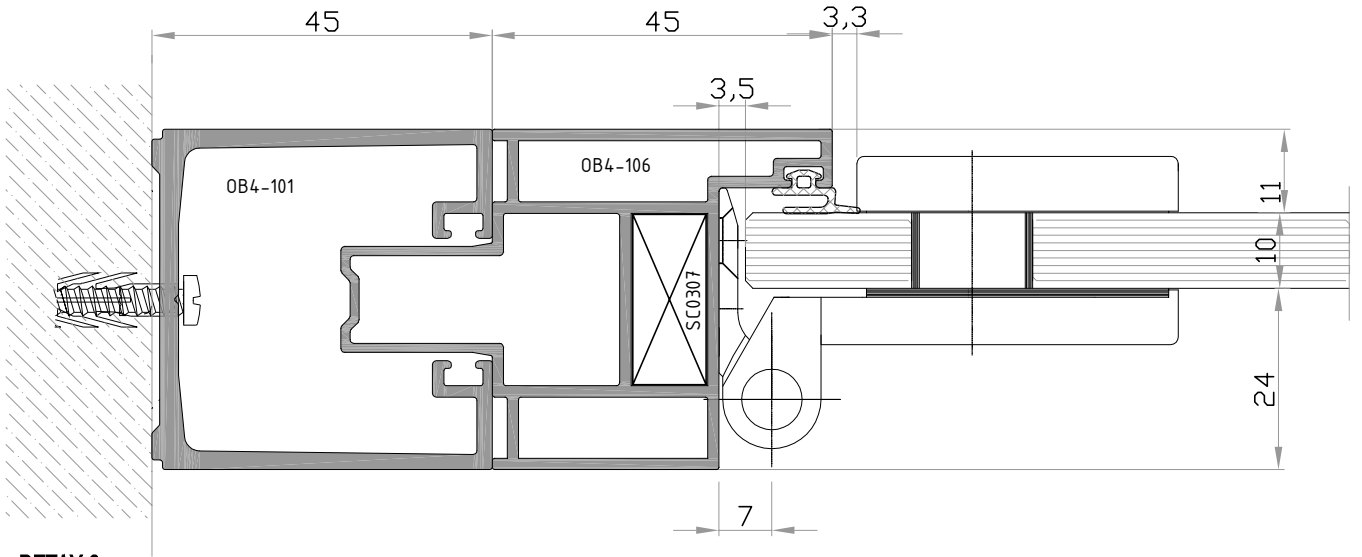
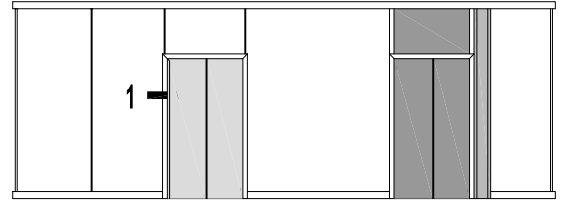
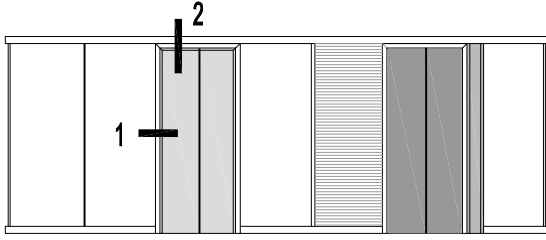

DETAY-2

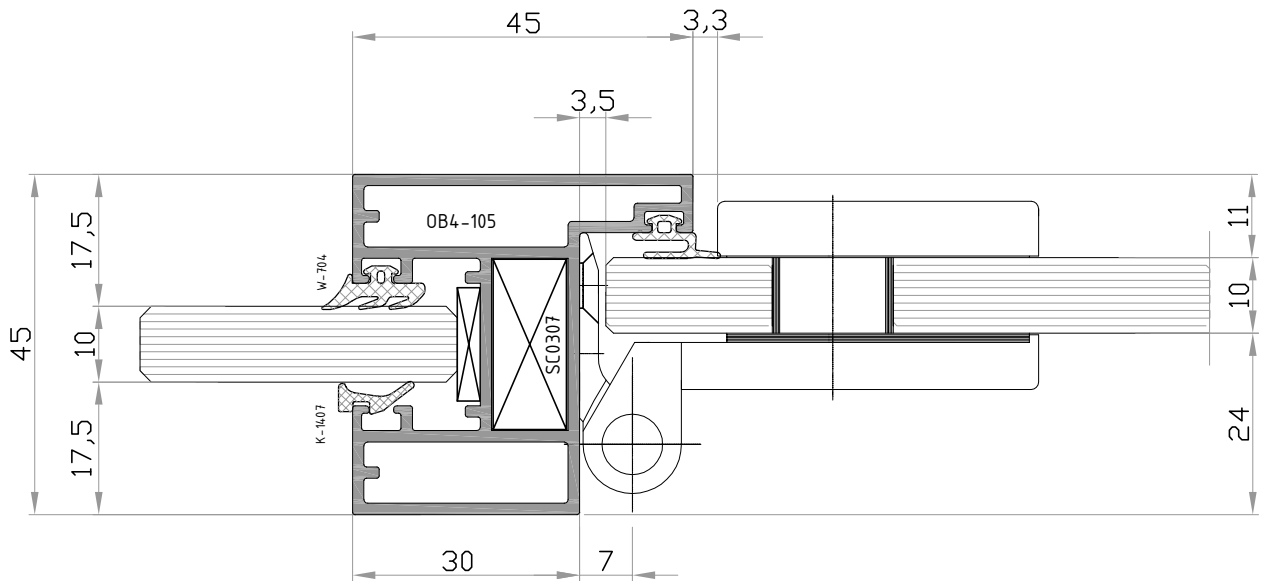

DETAY-1

OB4 - 45
CAM CAMA BÖLME
GLASS TO GLASS PARTITION

CAMDAN AHSAP PANELE GEÇİŞ

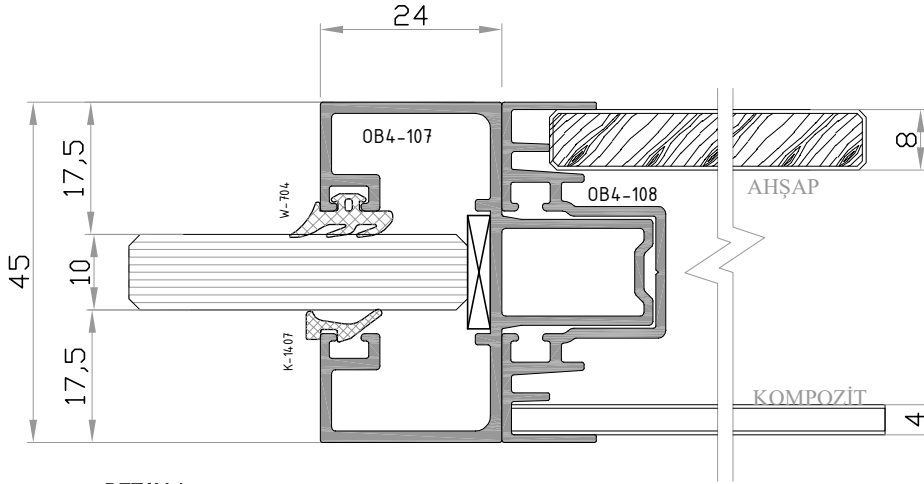
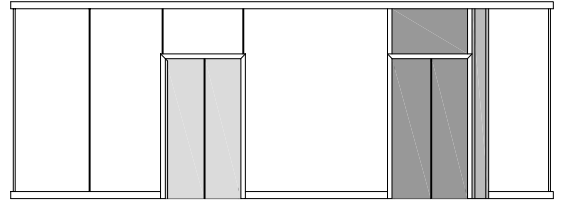
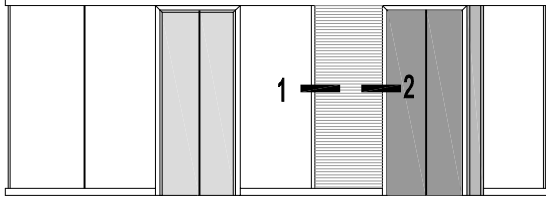

DETAY-1

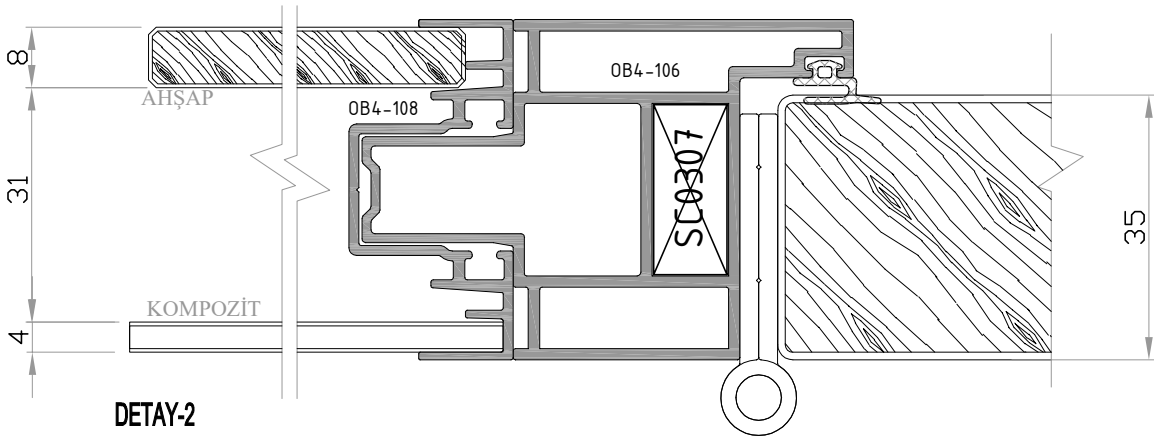

DETAY-2

OB4 - 45
CAM CAMA BÖLME
GLASS TO GLASS PARTITION

AHŞAP PANEL DETAYLARI

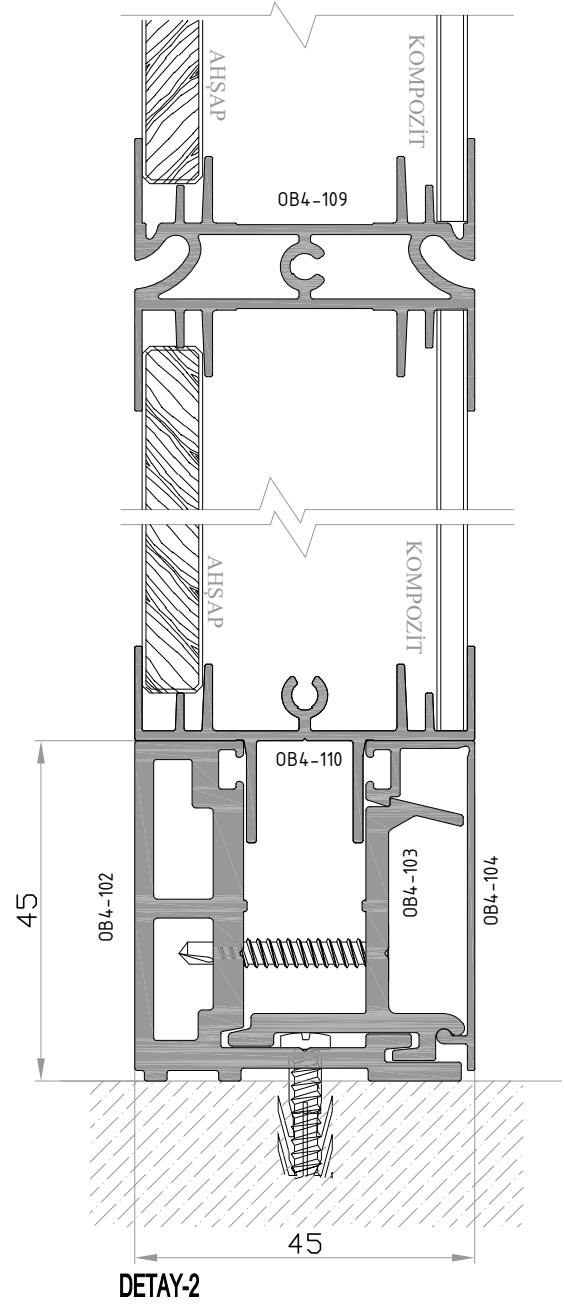
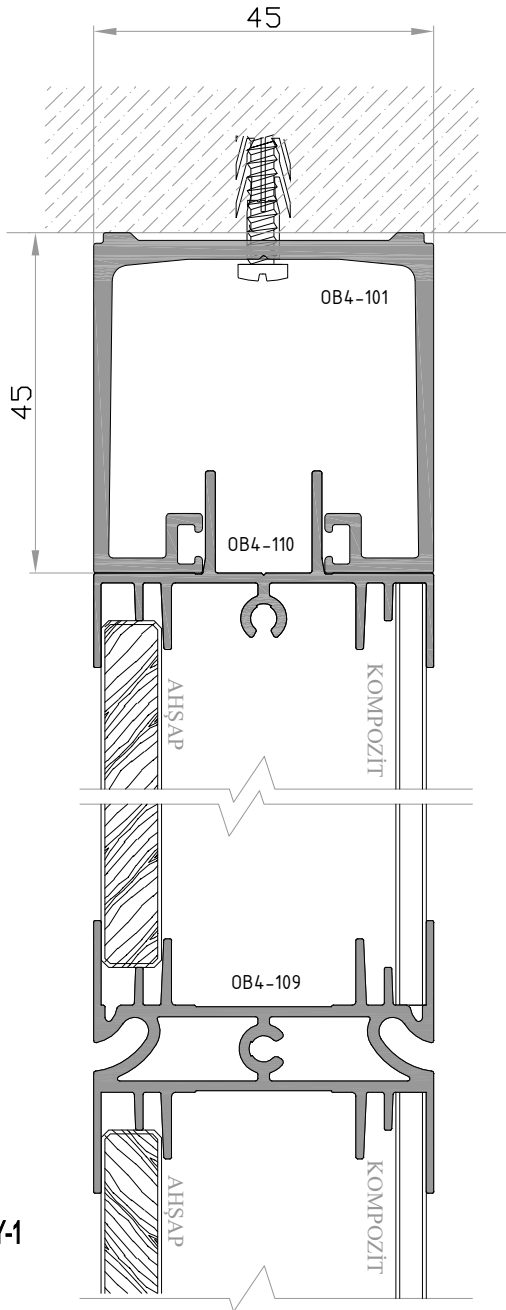
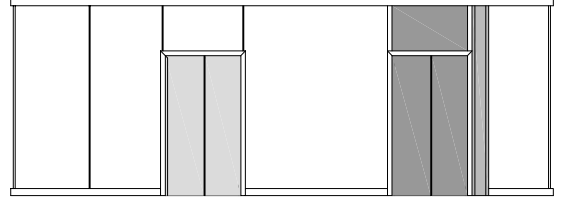
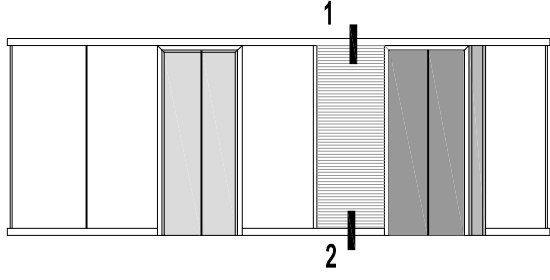

OB4 - 45
CAM CAMA BÖLME
GLASS TO GLASS PARTITION

AHŞAP PANEL RAF ASKI
.....

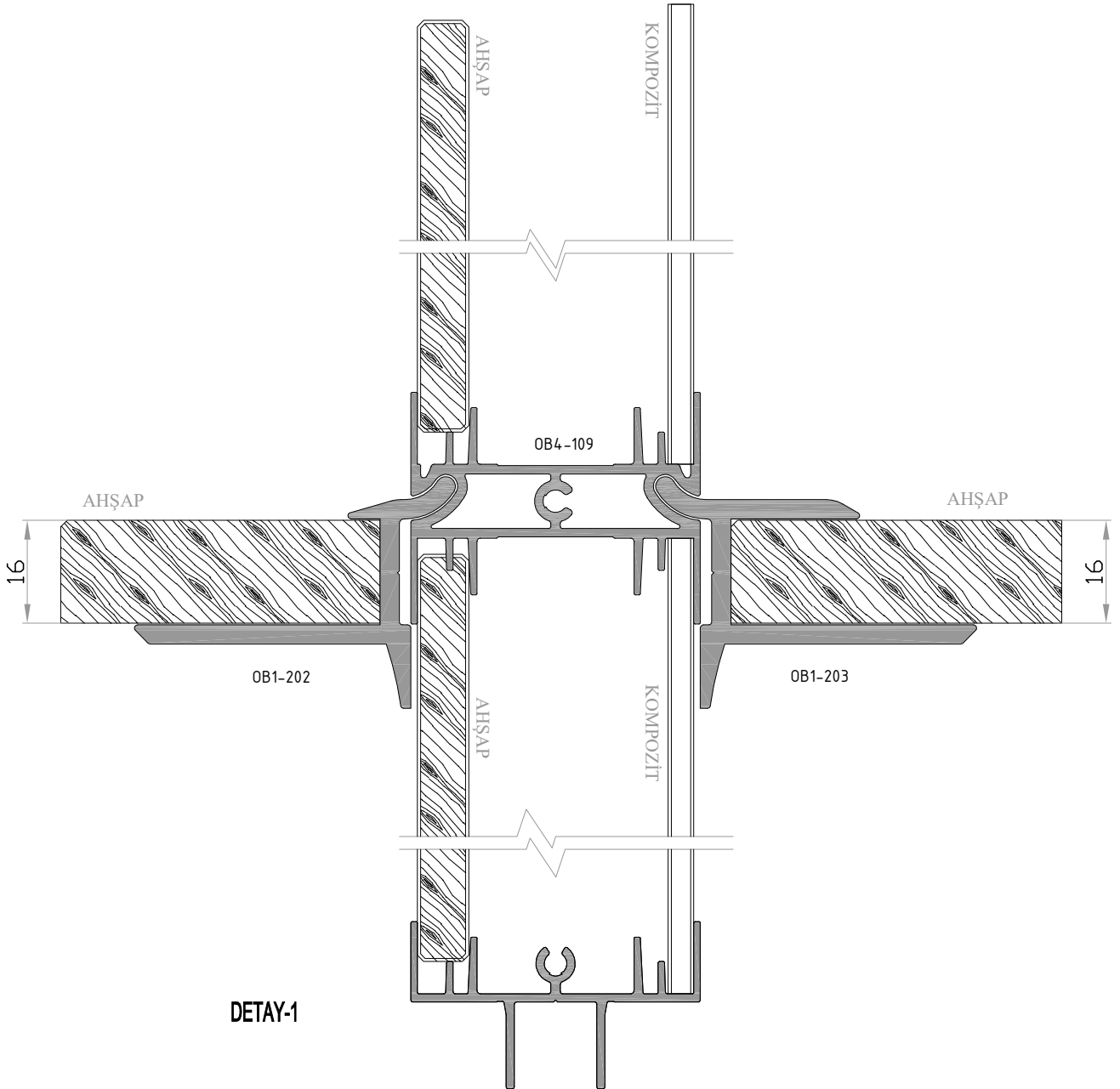
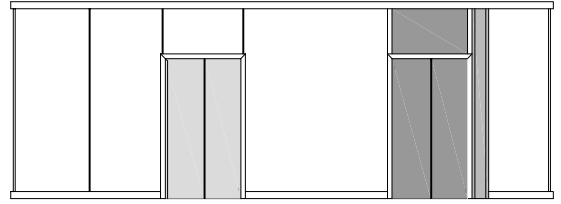
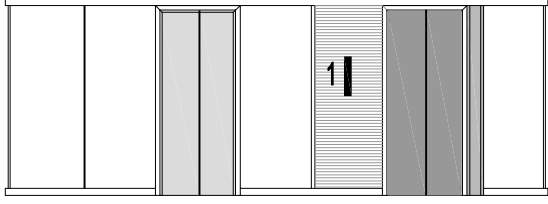

OB4 - 45
CAM CAMA BÖLME
GLASS TO GLASS PARTITION

AHŞAP KAPI VE KABLO KANAL
.....

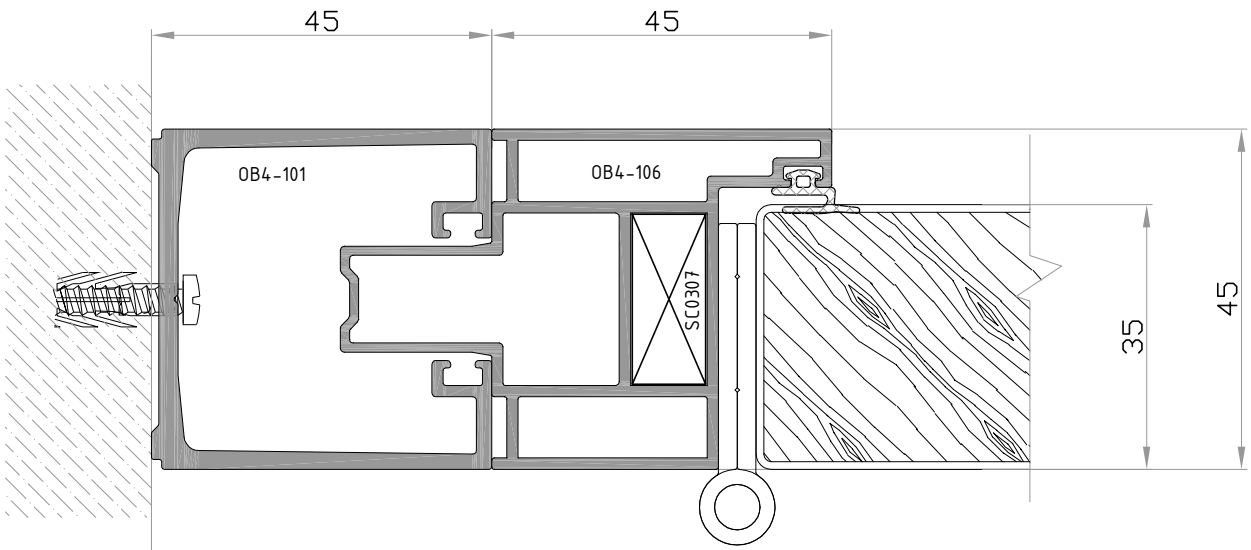
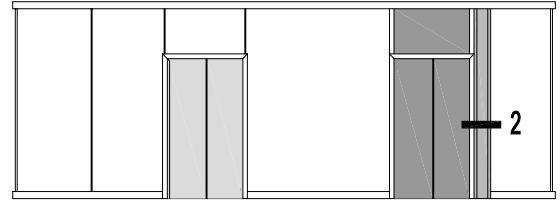
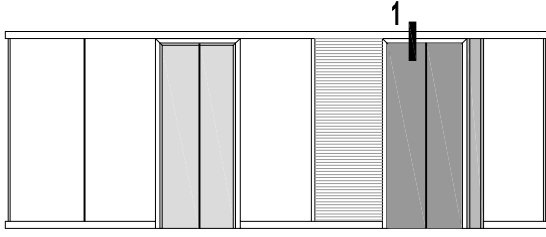

DETAY-1

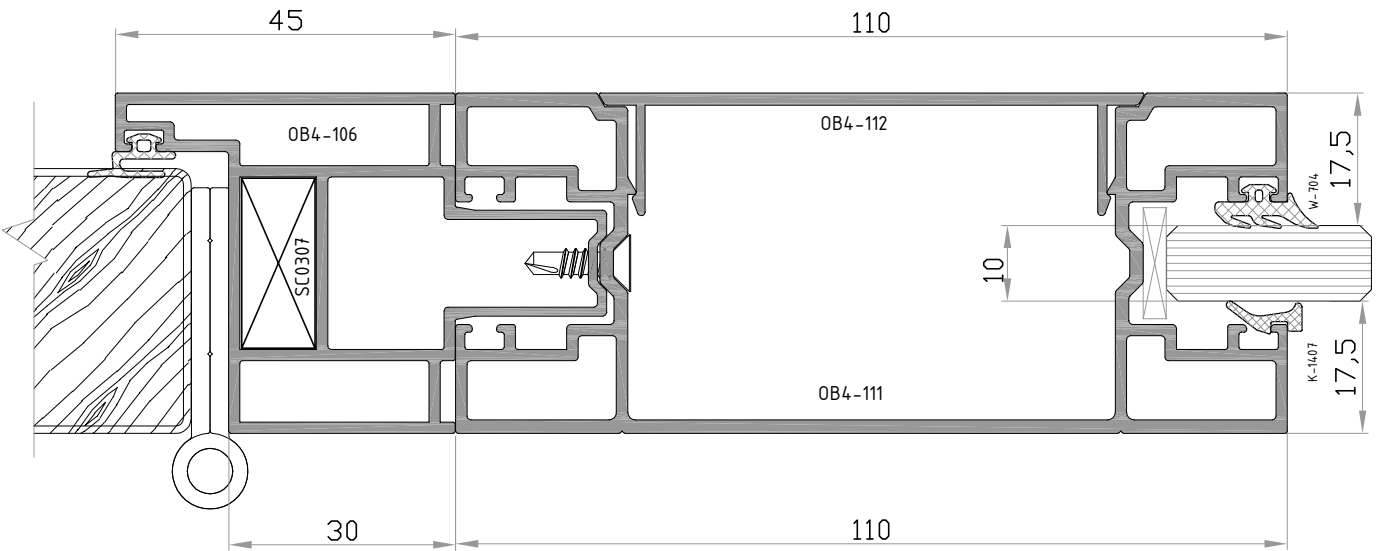

DETAY-2

OB4 - 45
CAM CAMA BÖLME
GLASS TO GLASS PARTITION

AHŞAP KAPI VE AHŞAP PANEL
.....

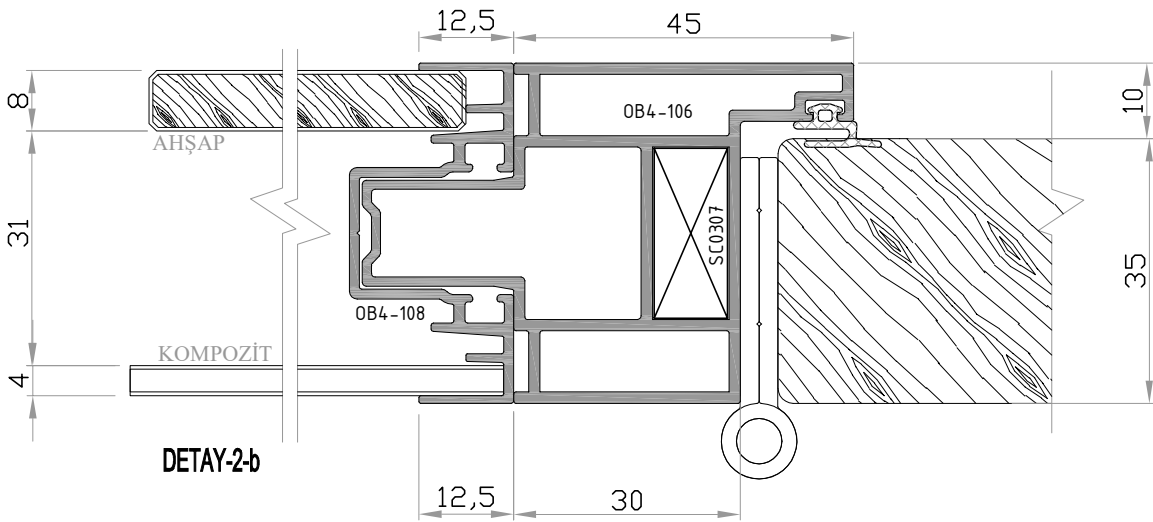
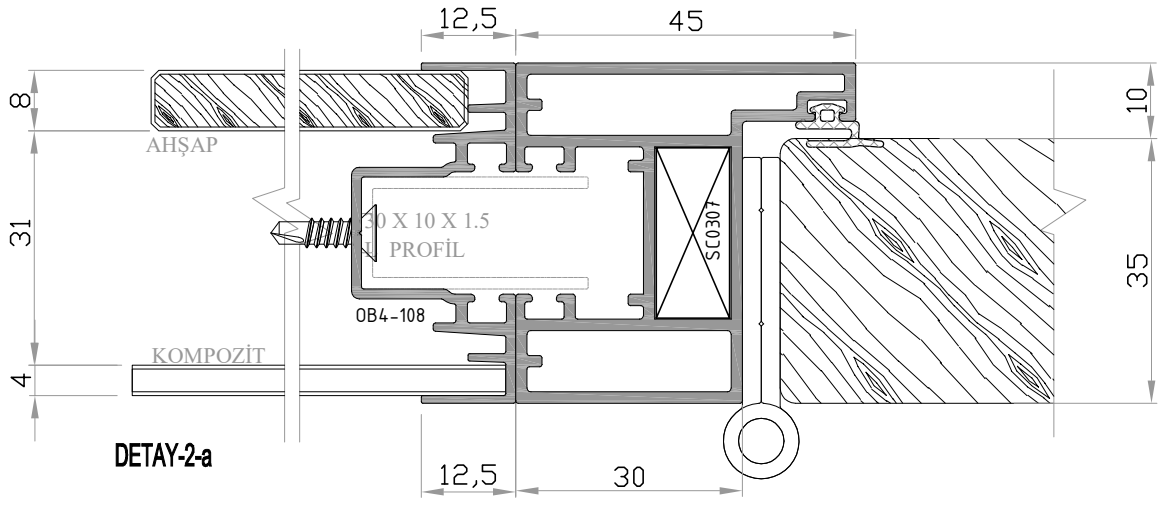
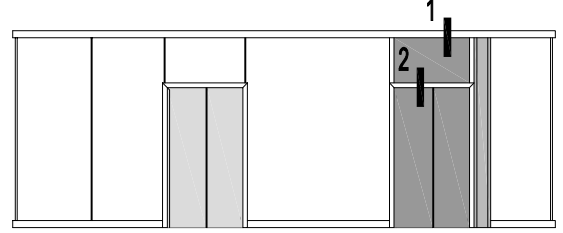

OB4 - 45
CAM CAMA BÖLME
GLASS TO GLASS PARTITION

AHŞAP PANEL İMALAT ŞEMASI

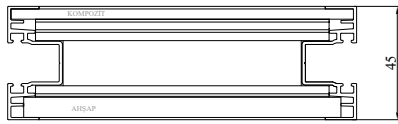
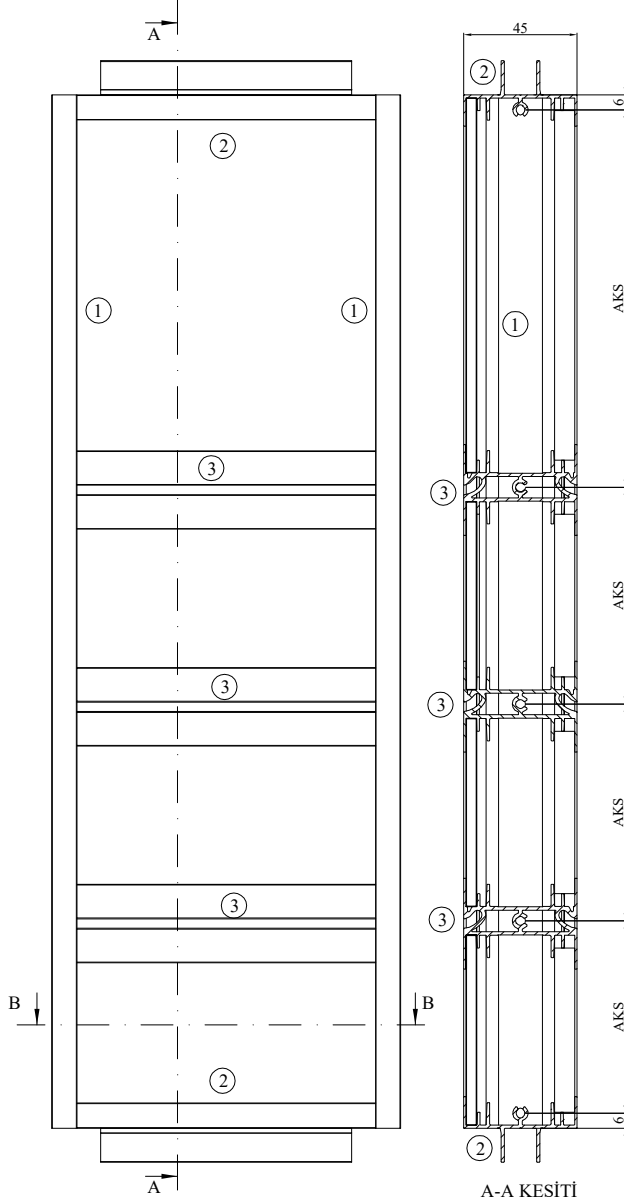

B-B KESİTİ

OB4-45 OFİS BÖLME SİSTEMİMİZDE
AHŞAP PANEL UYGULAMASINDA
4 mm KOMPOZİT MALZEME VE
8 mm AHŞAP, MDF, SUNTALAM
MALZEME KULLANIMINA OLANAK
SAĞLANMIŞTIR

2 -AHŞAP PANEL ALT & ÜST PROFİL

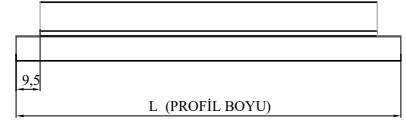
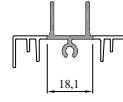

L (PROFİL BOYU)

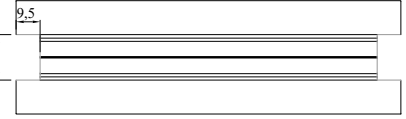

PROFİL HER İKİ UÇTAN 9.5 MM
DEİNLİĞİNDE KERTİLECEK

2 -AHŞAP PANEL RAF ASKI PROFİLİ

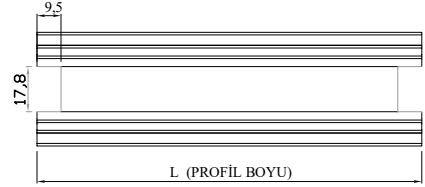
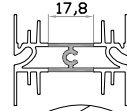

L (PROFİL BOYU)

PROFİL HER İKİ UÇTAN 9.5 MM
DEİNLİĞİNDE KERTİLECEK

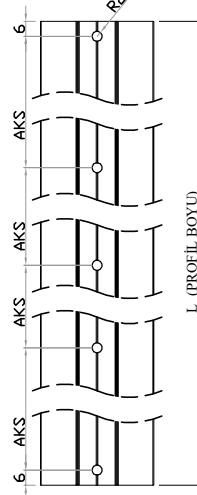
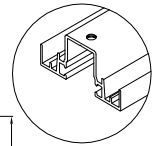
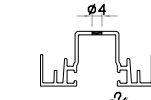

1-AHŞAP PANEL SAĞ SOL YAN PROFİLİ

OB4 - 45
CAM CAMA BÖLME
GLASS TO GLASS PARTITION

AHŞAP PANEL İMALAT ŞEMASI

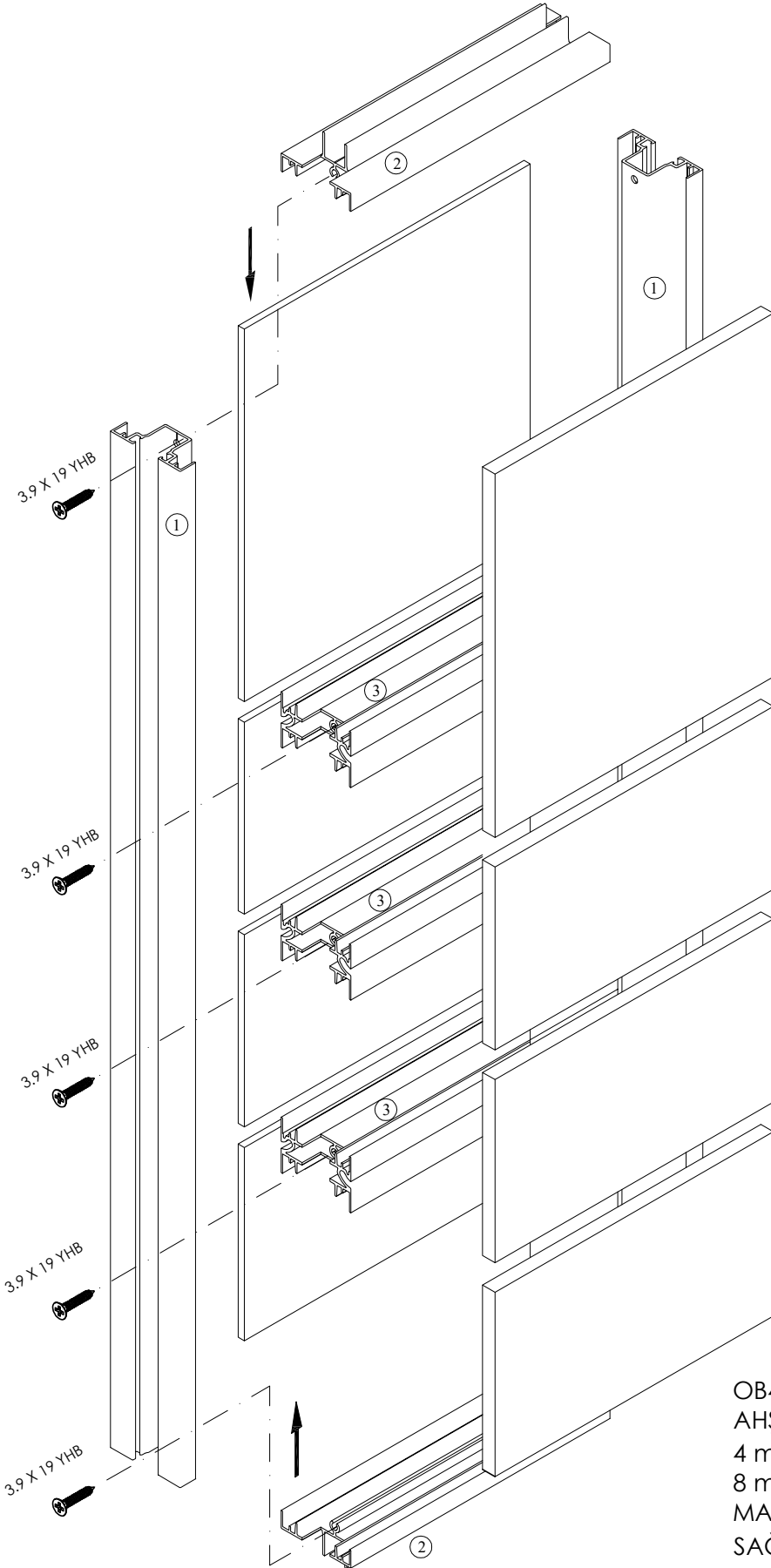

OB4-45 OFİS BÖLME SİSTEMİMİZDE
AHŞAP PANEL UYGULAMASINDA
4 mm KOMPOZİT MALZEME VE
8 mm AHŞAP, MDF, SUNTALAM
MALZEME KULLANIMINA OLANAK
SAĞLANMIŞTIR

OB4 - 45
CAM CAMA BÖLME
GLASS TO GLASS PARTITION

KAPI KASASI İMALAT ŞEMASI

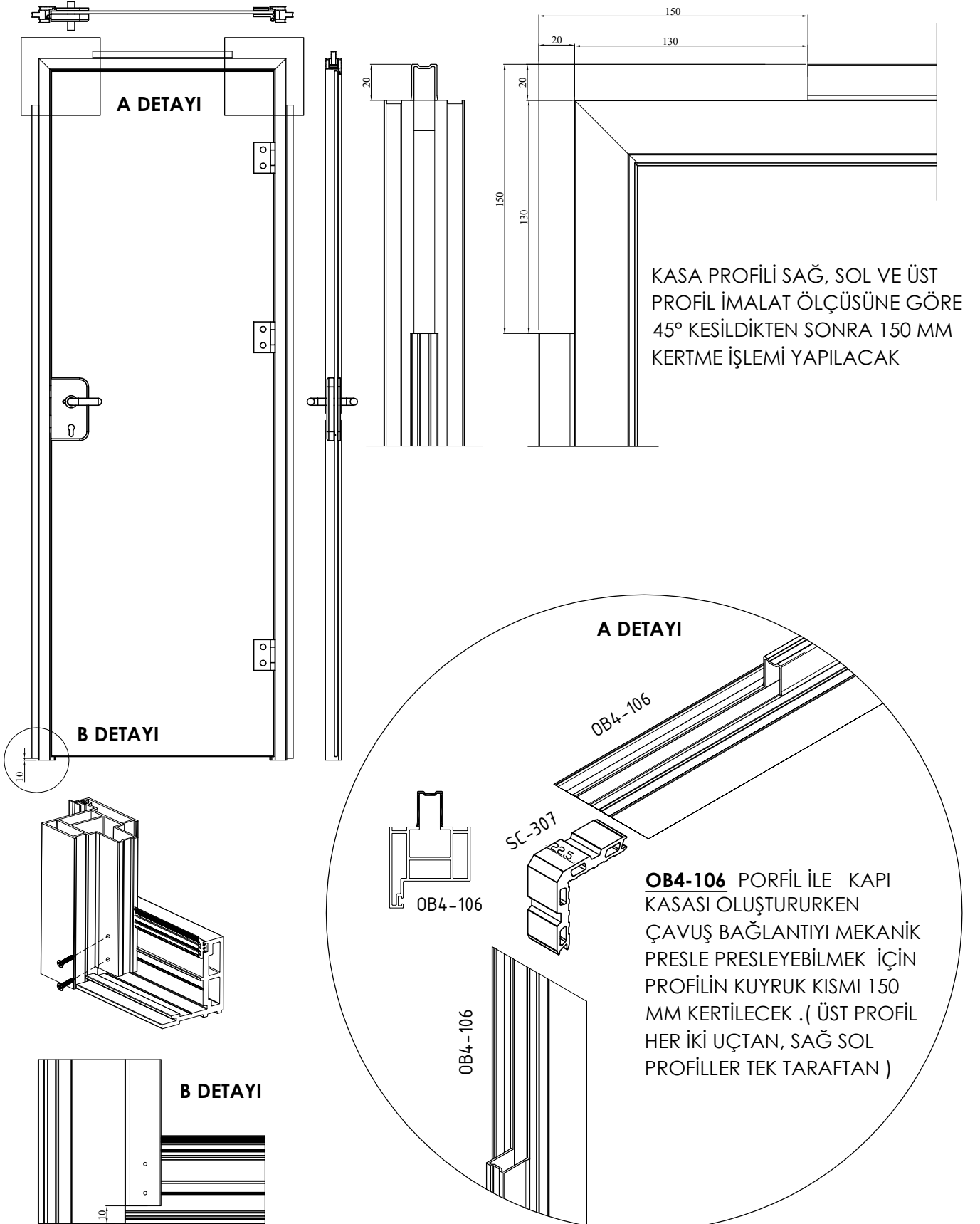

OB4 - 45
CAM CAMA BÖLME
GLASS TO GLASS PARTITION

KAPI KASASI İMALAT ŞEMASI

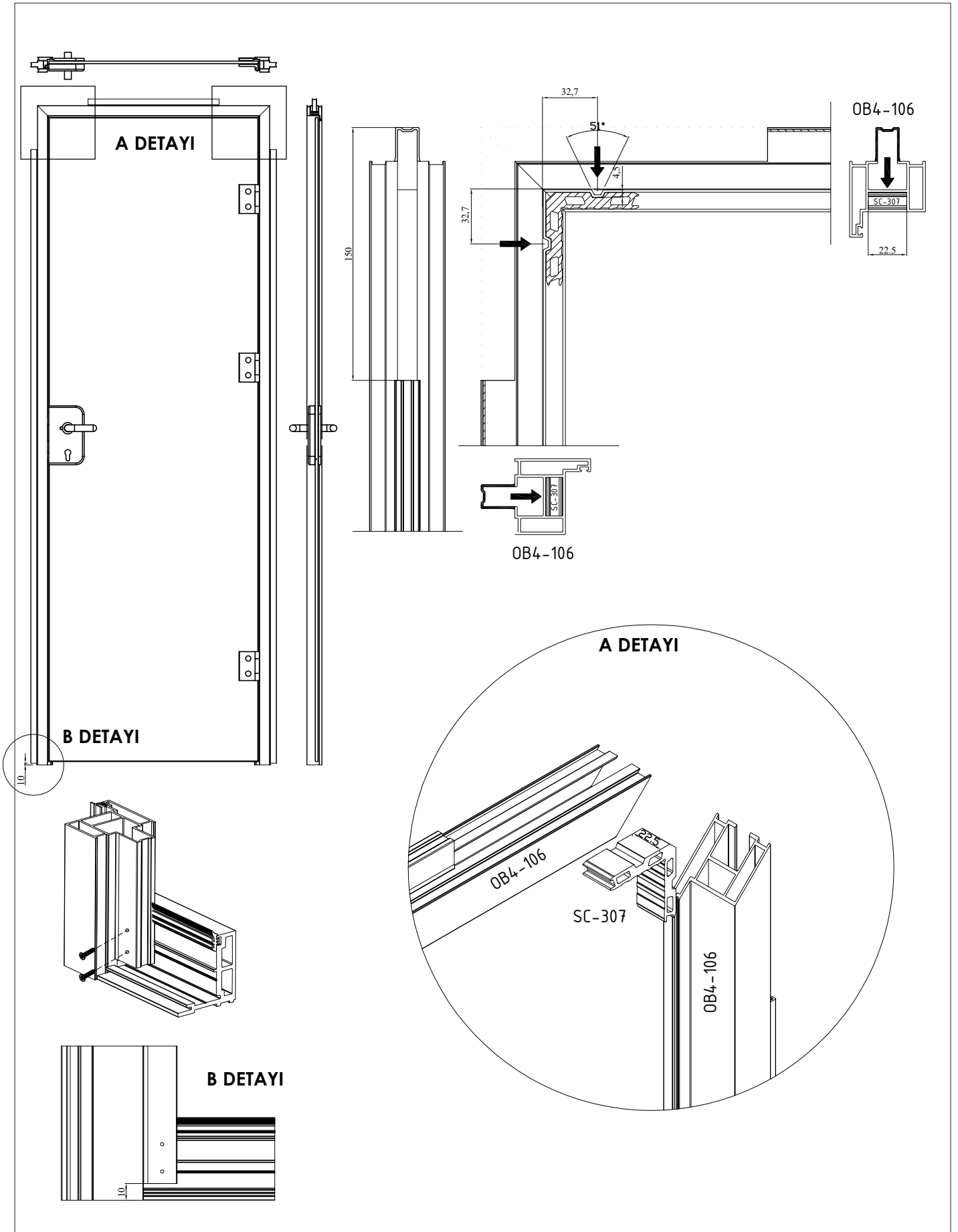

OB4 - 45
CAM CAMA BÖLME
GLASS TO GLASS PARTITION

CAM VE AĖŞAP PANEL
İMALAT ÖLÇÜLERİ

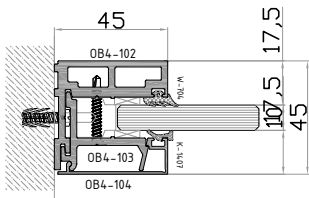
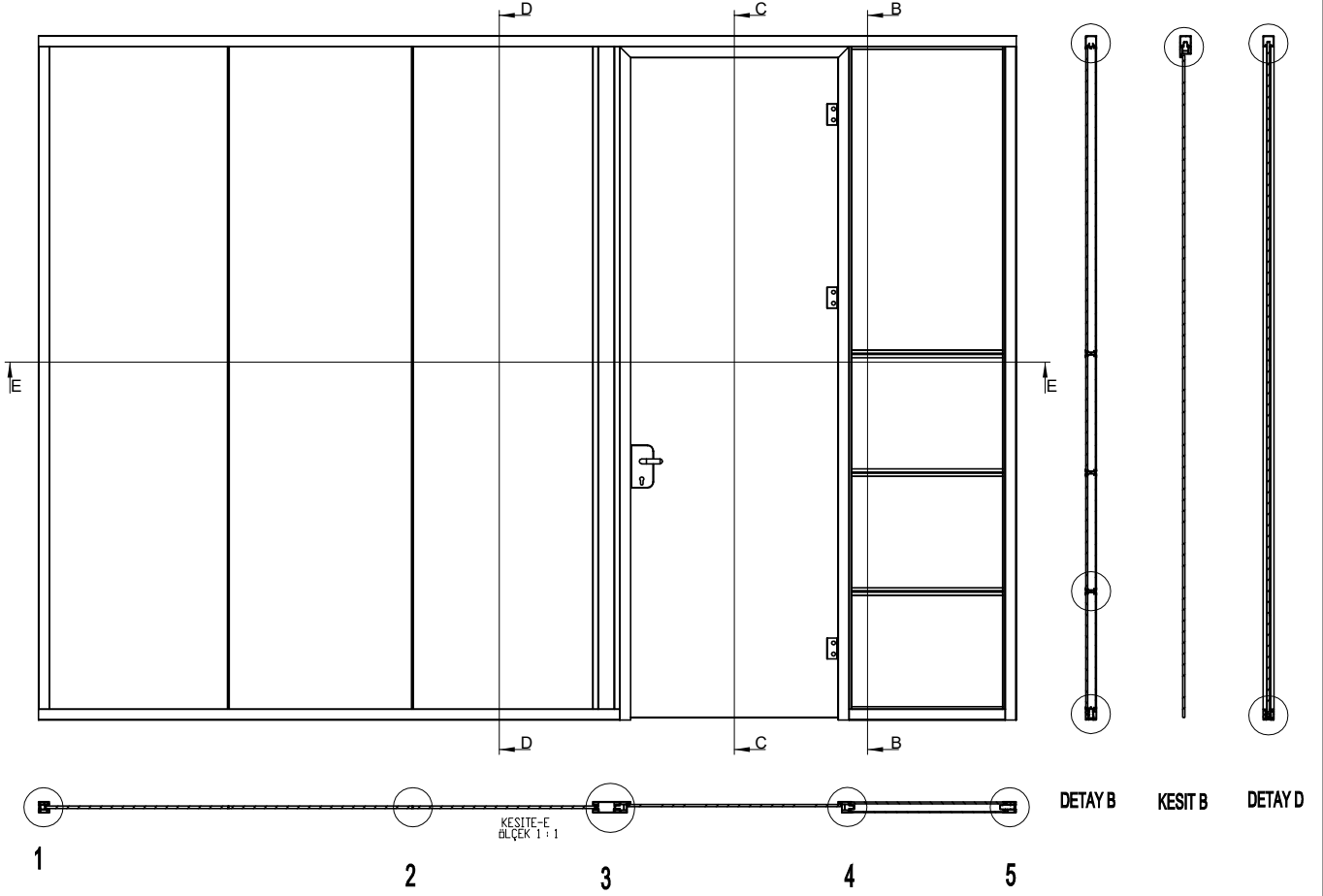

1-DETAY

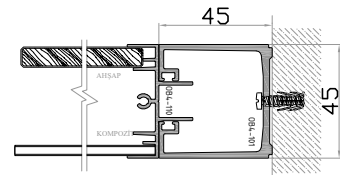

5-DETAY

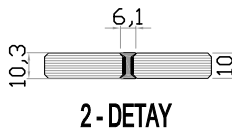

2-DETAY

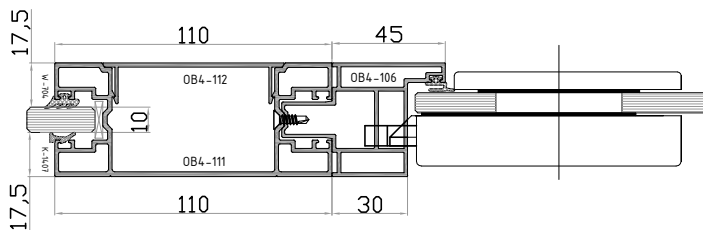

3-DETAY

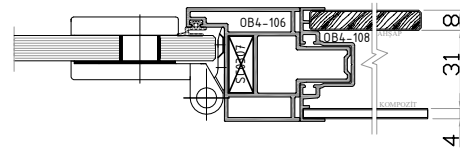

4-DETAY

OB4 - 45
CAM CAMA BÖLME
GLASS TO GLASS PARTITION

CAM VE AHSAP PANEL
İMALAT ÖLÇÜLERİ

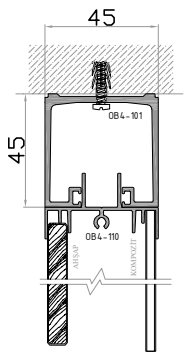
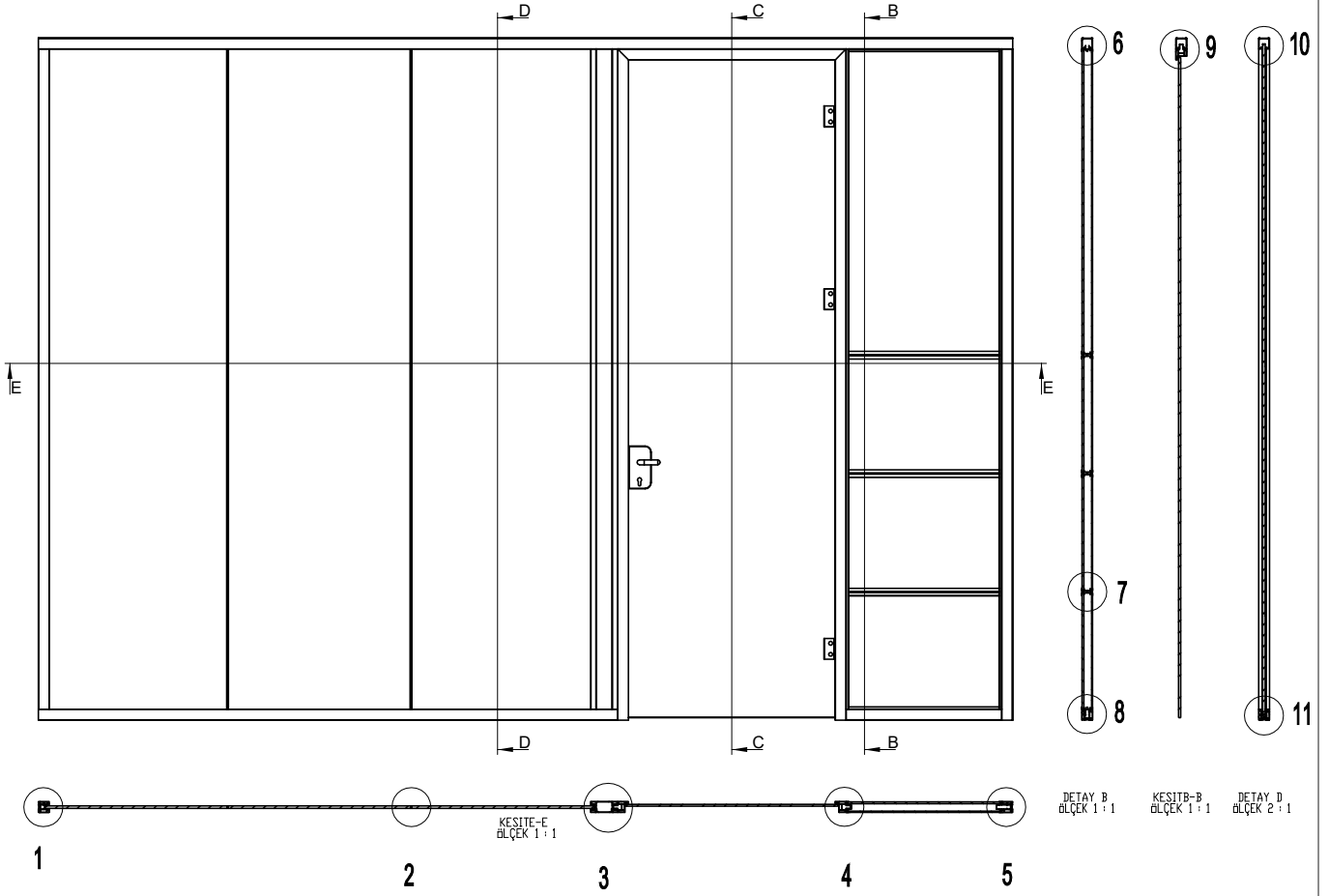

6 - DETAY

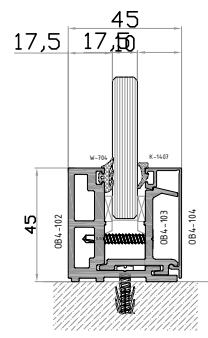

8 - DETAY

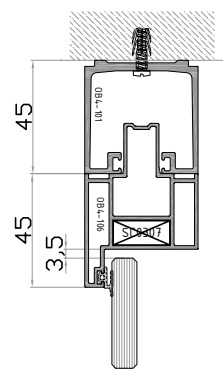

9 - DETAY

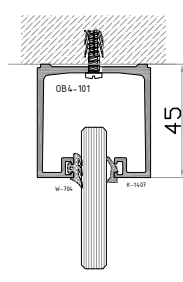

10 - DETAY

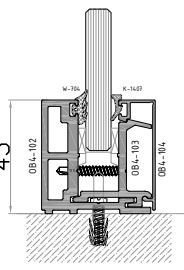

11 - DETAY

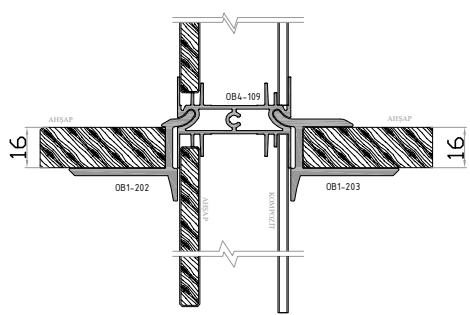

7 - DETAY

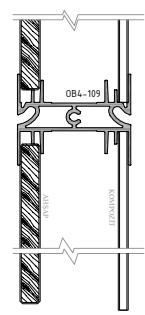

7 - DETAY

OB4 - 45
CAM CAMA BÖLME
GLASS TO GLASS PARTITION

CAM VE AĖSAP PANEL
İMALAT ÖLÇÜLERİ

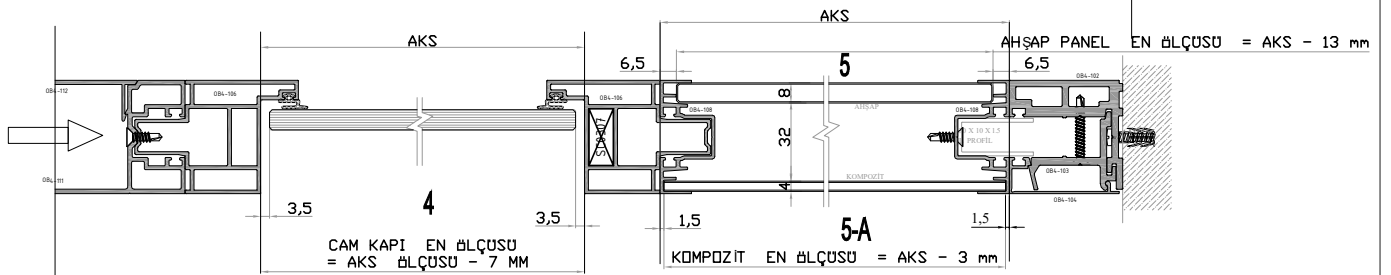
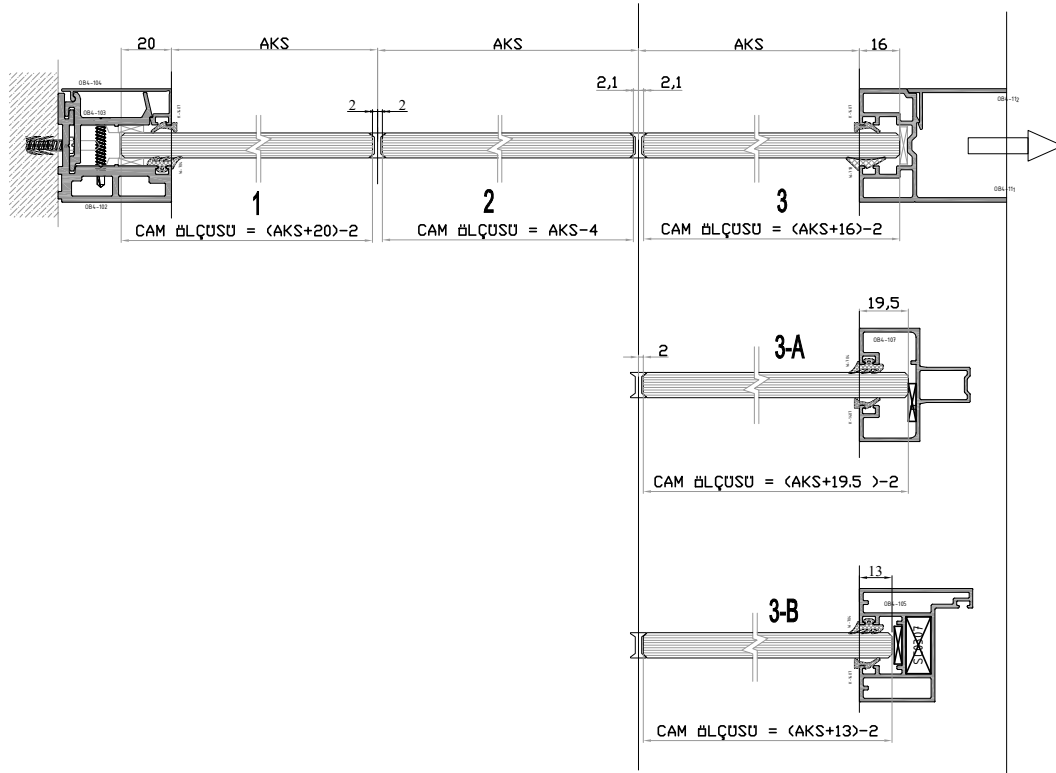
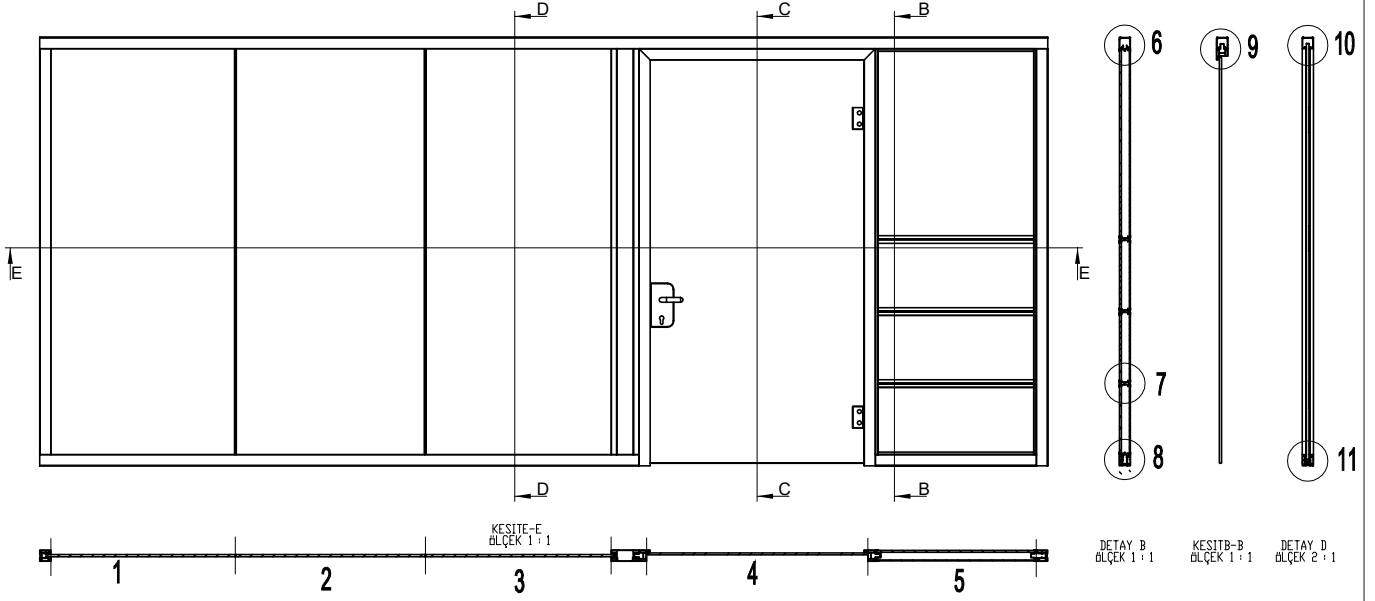

OB4 - 45
CAM CAMA BÖLME
GLASS TO GLASS PARTITION

CAM VE AHSAP PANEL
İMALAT ÖLÇÜLERİ

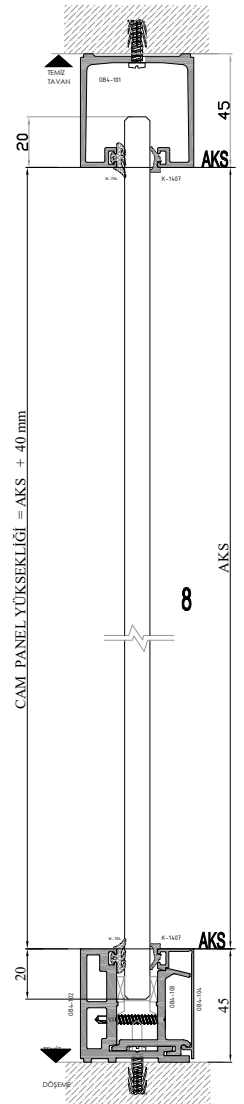
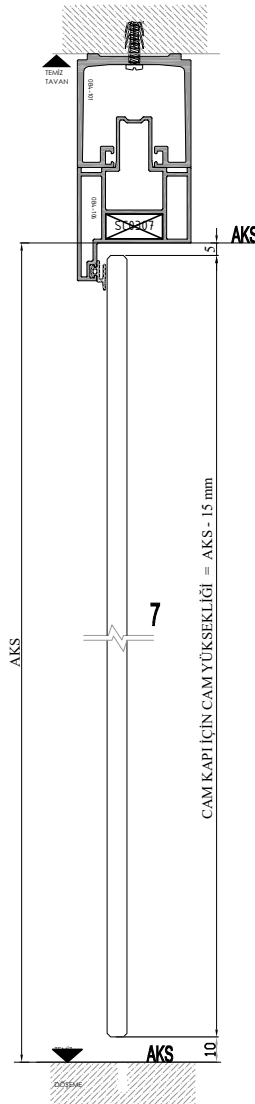
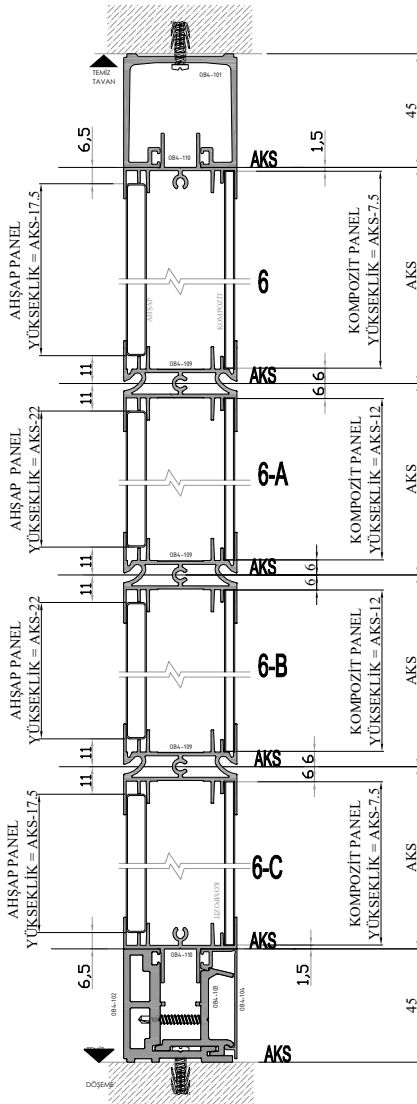
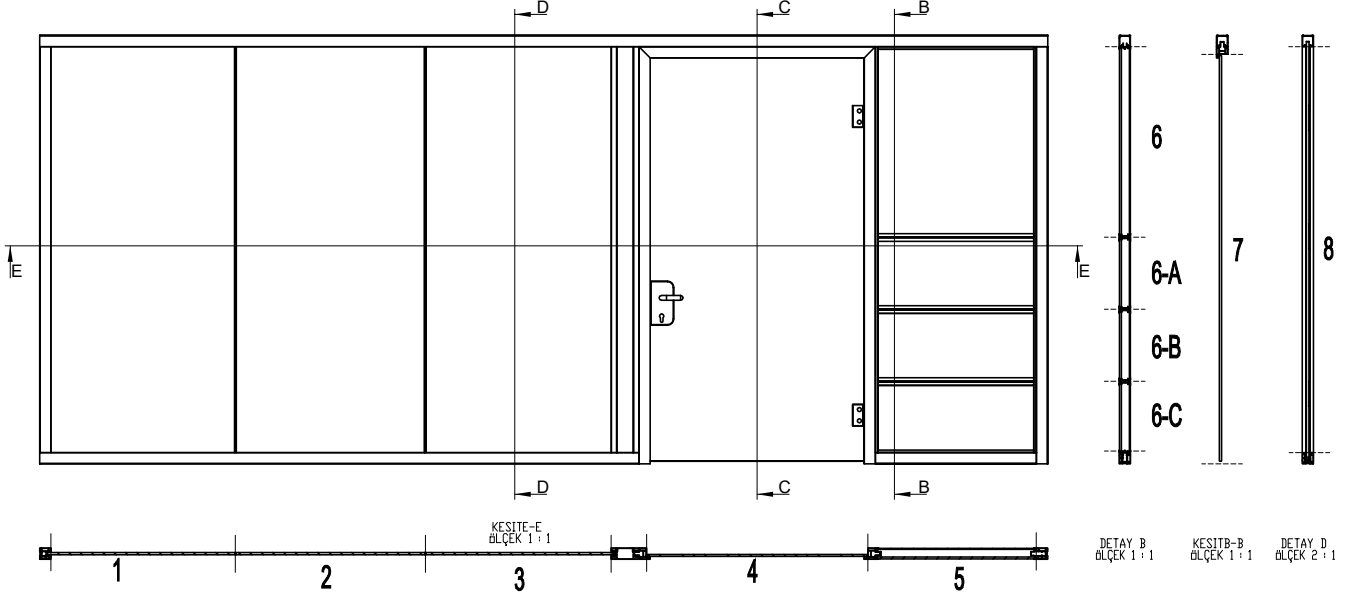

OB4 - 45
CAM CAMA BÖLME
GLASS TO GLASS PARTITION

PVC CAM TAKOZU
VE MONTAJ PROFİLİ

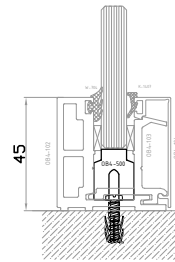
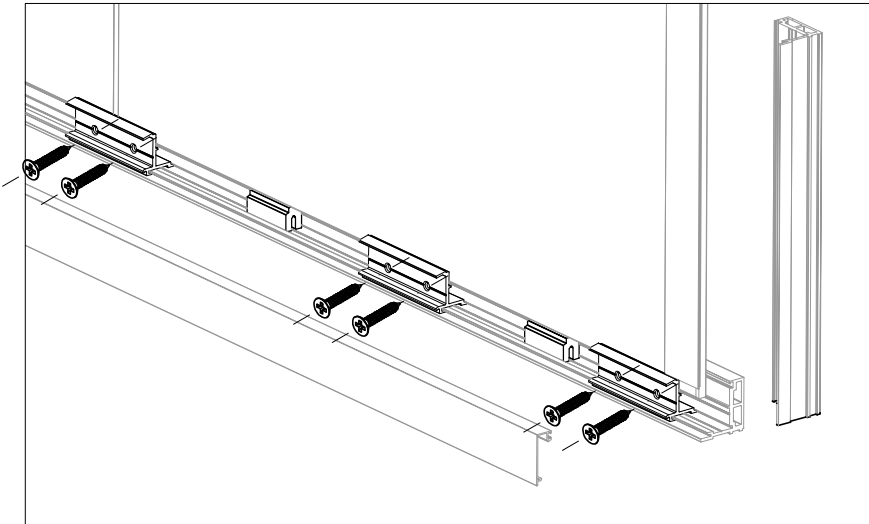
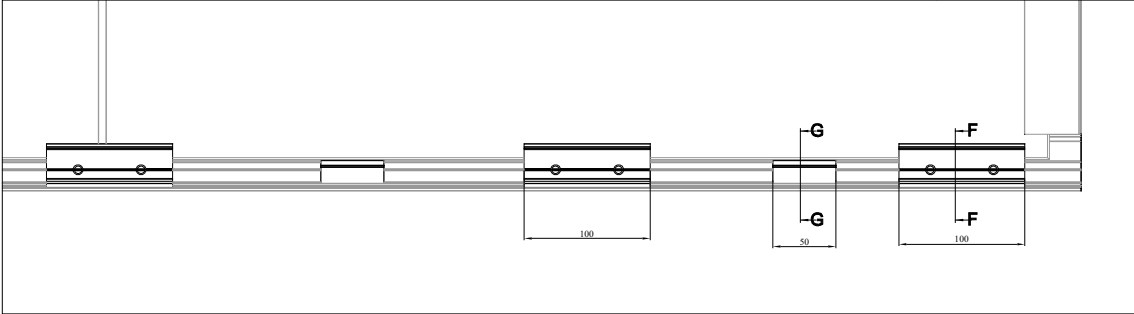
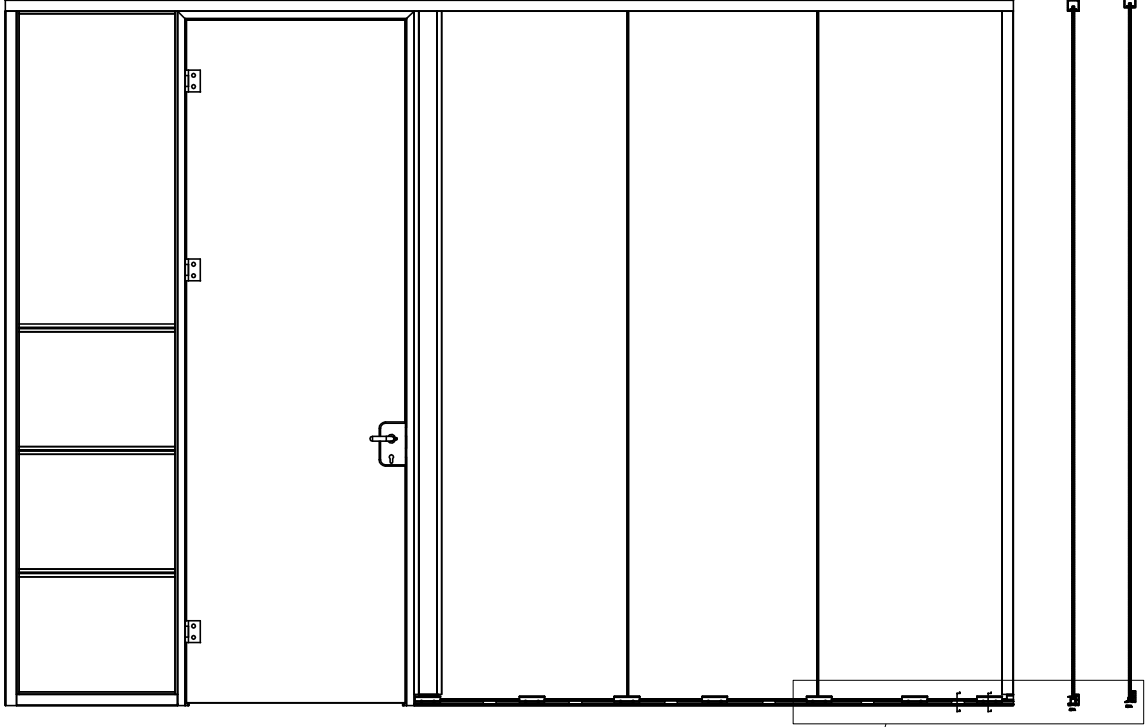

KESİT G-G
ÖLÇEK 1:1

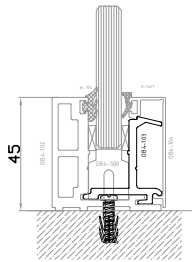

KESİT F-F
ÖLÇEK 1:1

OB4 - 45
CAM CAMA BÖLME
GLASS TO GLASS PARTITION

FİTİL listesi
Gasket list

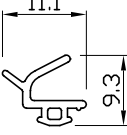
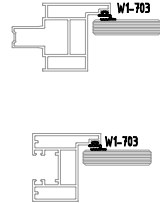
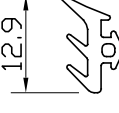
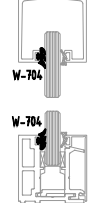
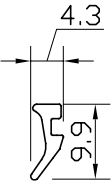
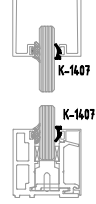
kod code	şekil drawing	tanım description	teorik ağırlık theoretical weight gr / m	paket ağırlığı package weight kg / package	paket metrajı in one package metre / package	kullanım yeri aplication
W1-703		epdm çarpma iç-dış fitil glazing acoustical (epdm)	33 gr/m	15 kg	440 m	
W-704		epdm cam dış fitil glazing gasket outside (epdm)	50 gr/m	15 kg	300 m	
K-1407		epdm kama fitil glazing gasket inside	23 gr/m	15 kg	652 m	

OB4 - 45
CAM CAMA BÖLME
GLASS TO GLASS PARTITION

CAM KAPI MENTEŞESİ
GLASS DOOR HINGE

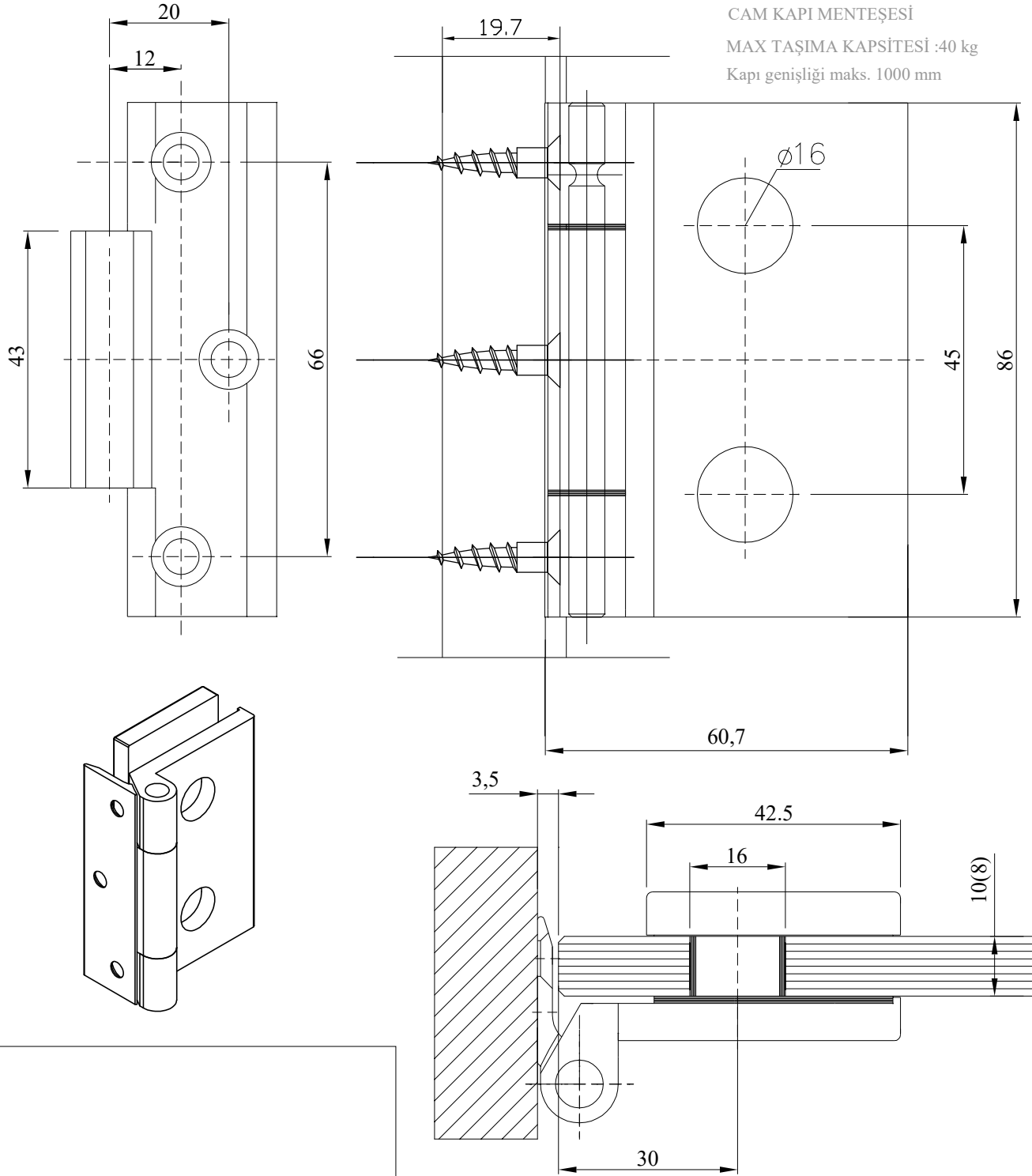

D:\DF?S BÖLME\ZEK? AYDIN TASARIM\UYGULAMA PLANLARI\CAM CAMA\dorno_mente?e.jpg

OB4 - 45
CAM CAMA BÖLME
GLASS TO GLASS PARTITION

CAM KAPI KİLİT AKS ÖLÇÜLERİ
GLASS DOOR LOCK AXIS DIMENSIONS

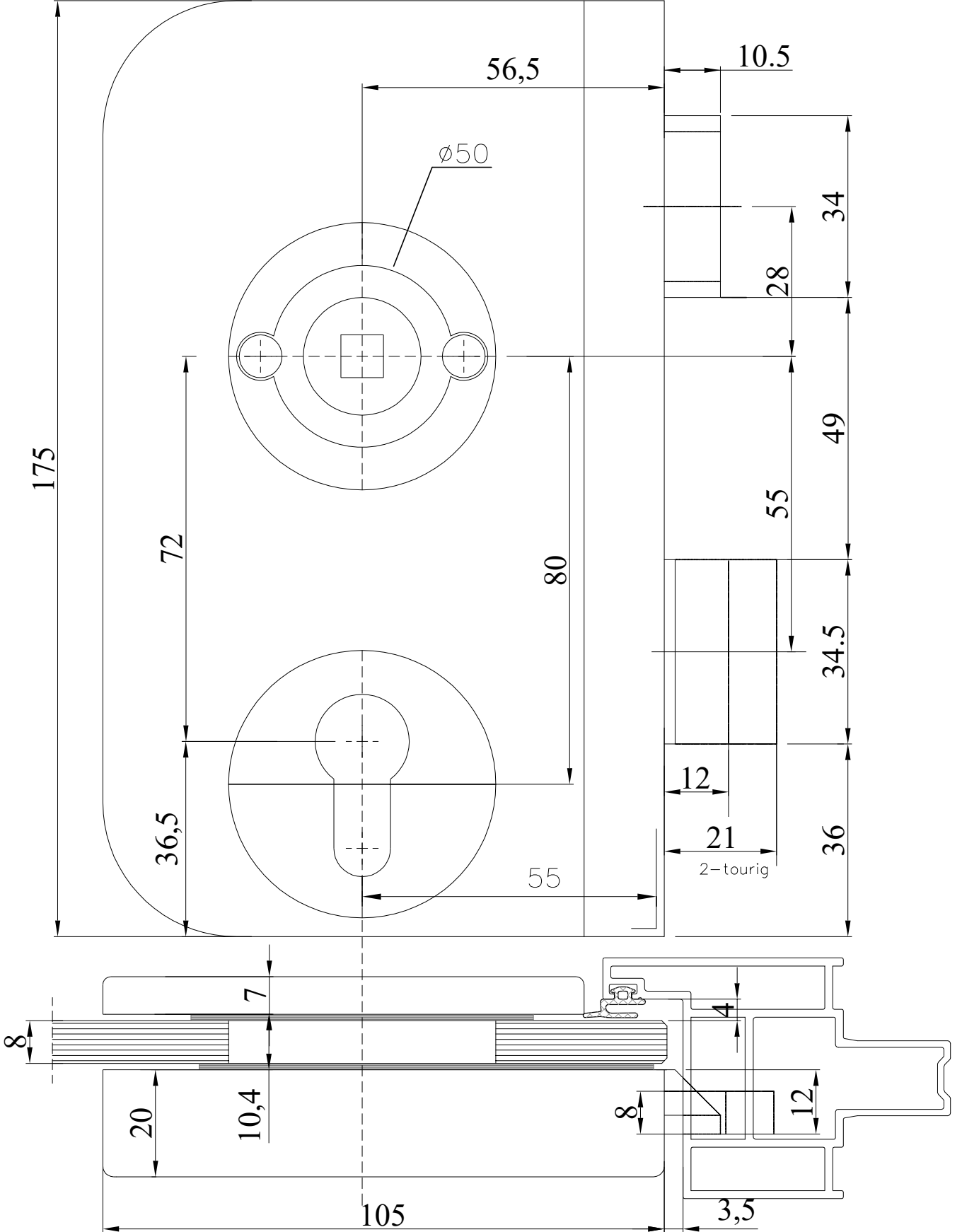

OB4 - 45
CAM CAMA BÖLME
GLASS TO GLASS PARTITION

CAM KAPI KİLİT AKS ÖLÇÜLERİ
GLASS DOOR LOCK AXIS DIMENSIONS

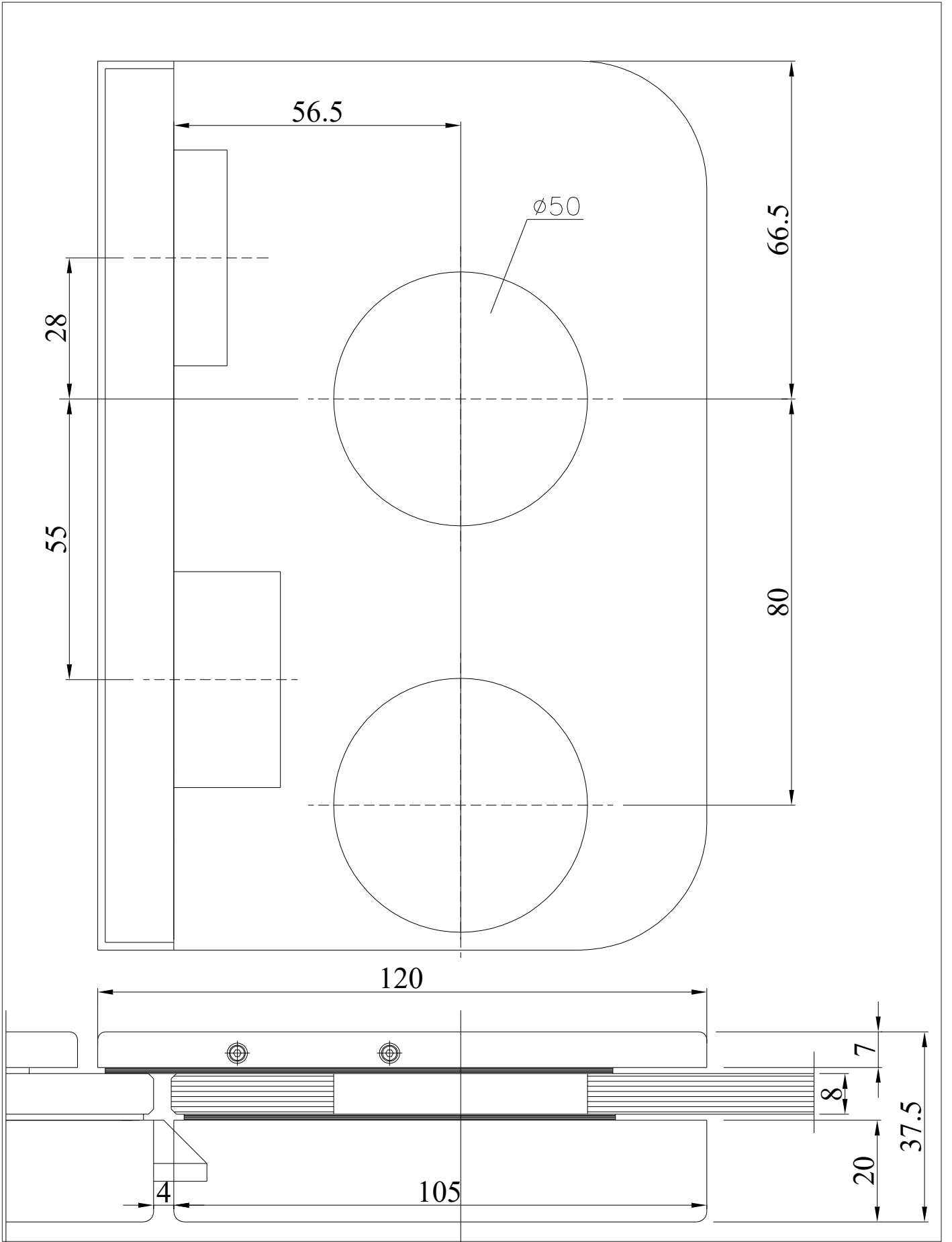

OB4 - 45
CAM CAMA BÖLME
GLASS TO GLASS PARTITION

CAM KAPI KİLİT AKS ÖLÇÜLERİ
GLASS DOOR LOCK AXIS DIMENSIONS

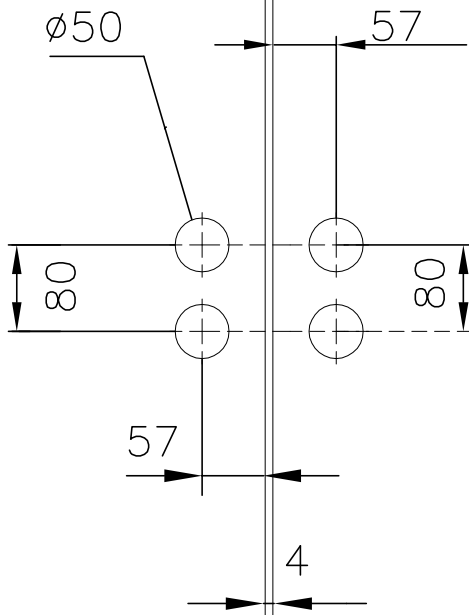
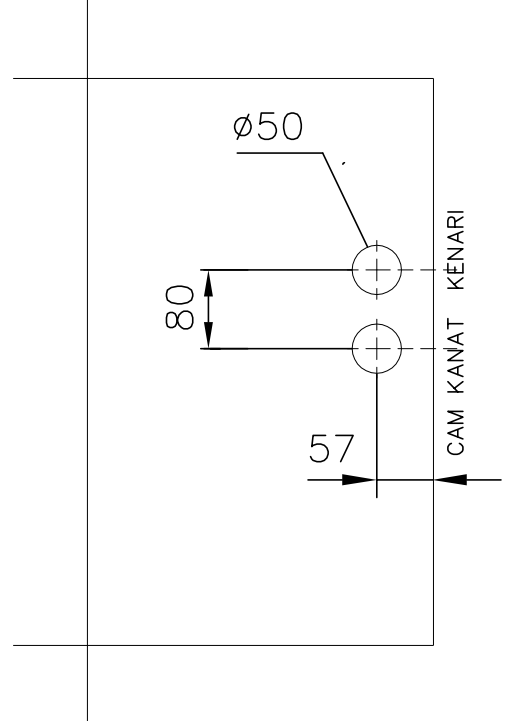
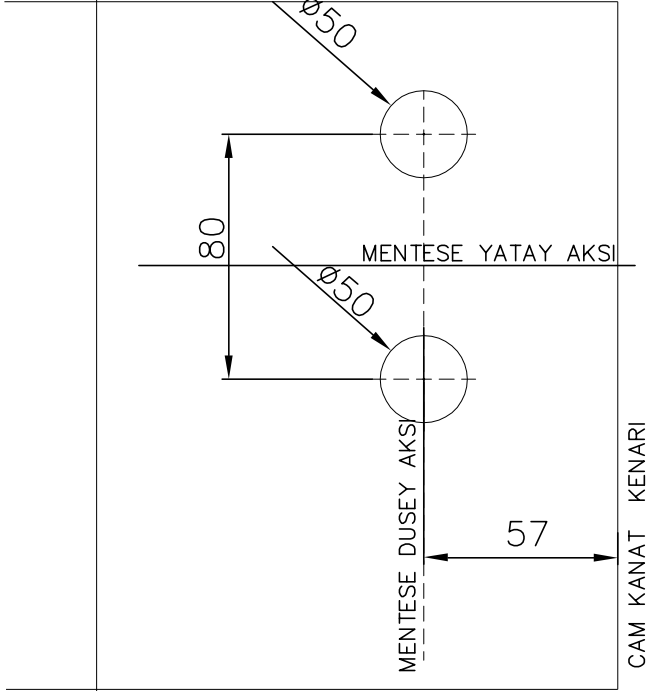

OB4 - 45
CAM CAMA BÖLME
GLASS TO GLASS PARTITION

KAPI AKSESUAR MONTAJ ÖLÇÜLERİ

DOOR ACCESSORIES
INSTALLATION DIMENSIONS

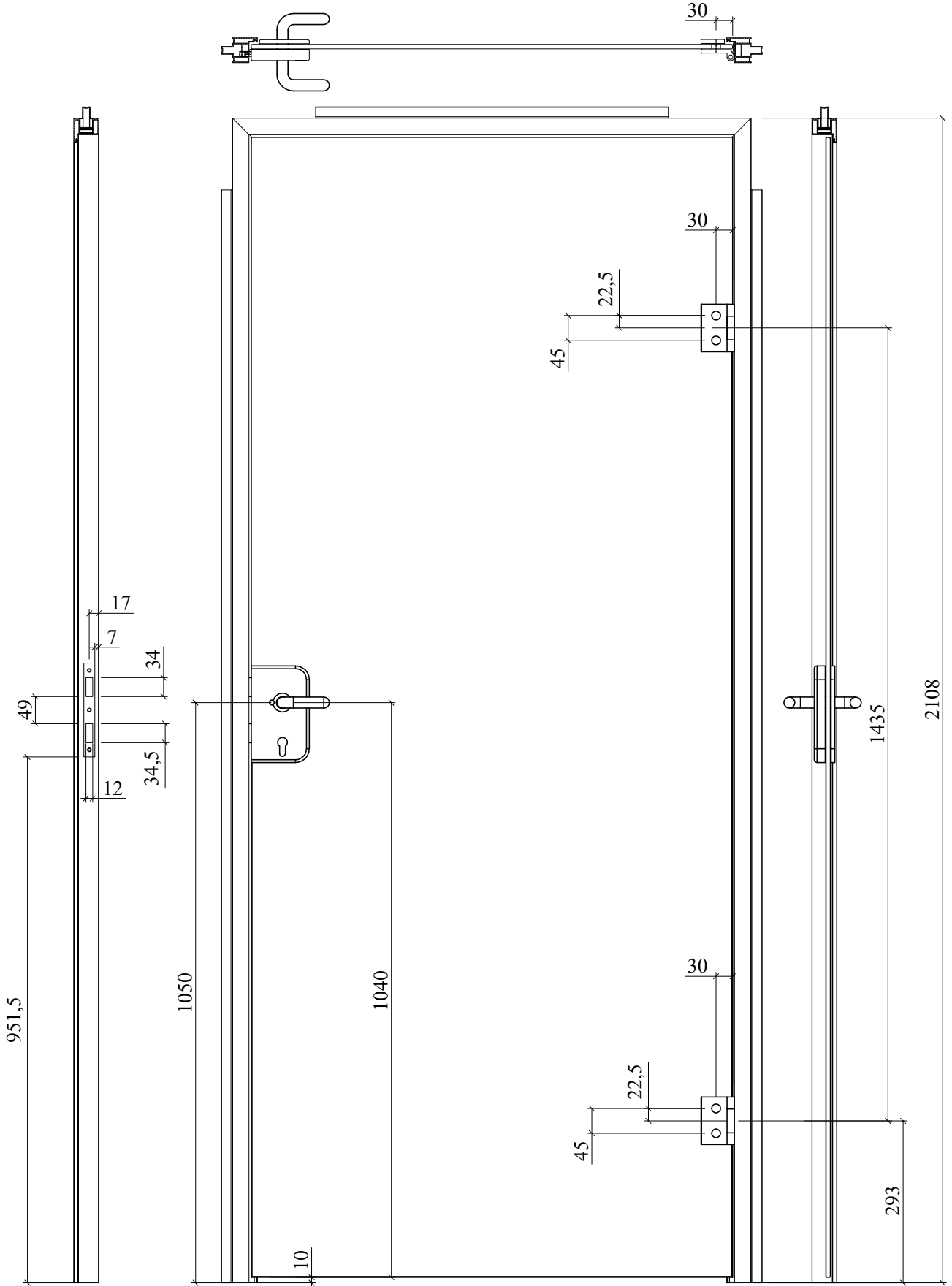

OB4 - 45
CAM CAMA BÖLME
GLASS TO GLASS PARTITION

KAPI AKSESUAR MONTAJ ÖLÇÜLERİ

DOOR ACCESSORIES
INSTALLATION DIMENSIONS

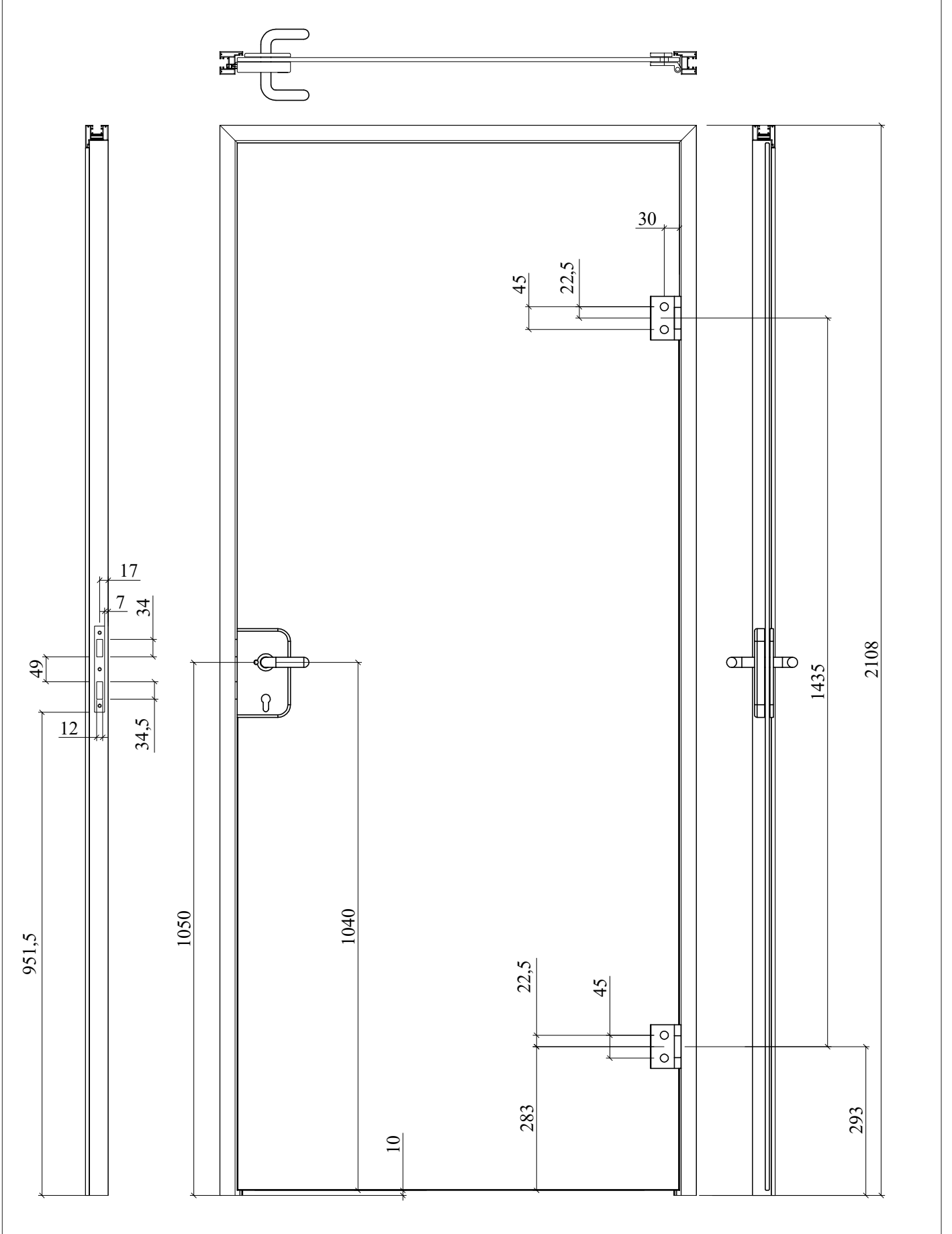

OB4 - 45
CAM CAMA BÖLME
GLASS TO GLASS PARTITION

TEK VE ÇİFT KANAT KAPI
AKSESUAR MONTAJ ÖLÇÜLERİ
DOOR ACCESSORIES
INSTALLATION DIMENSIONS

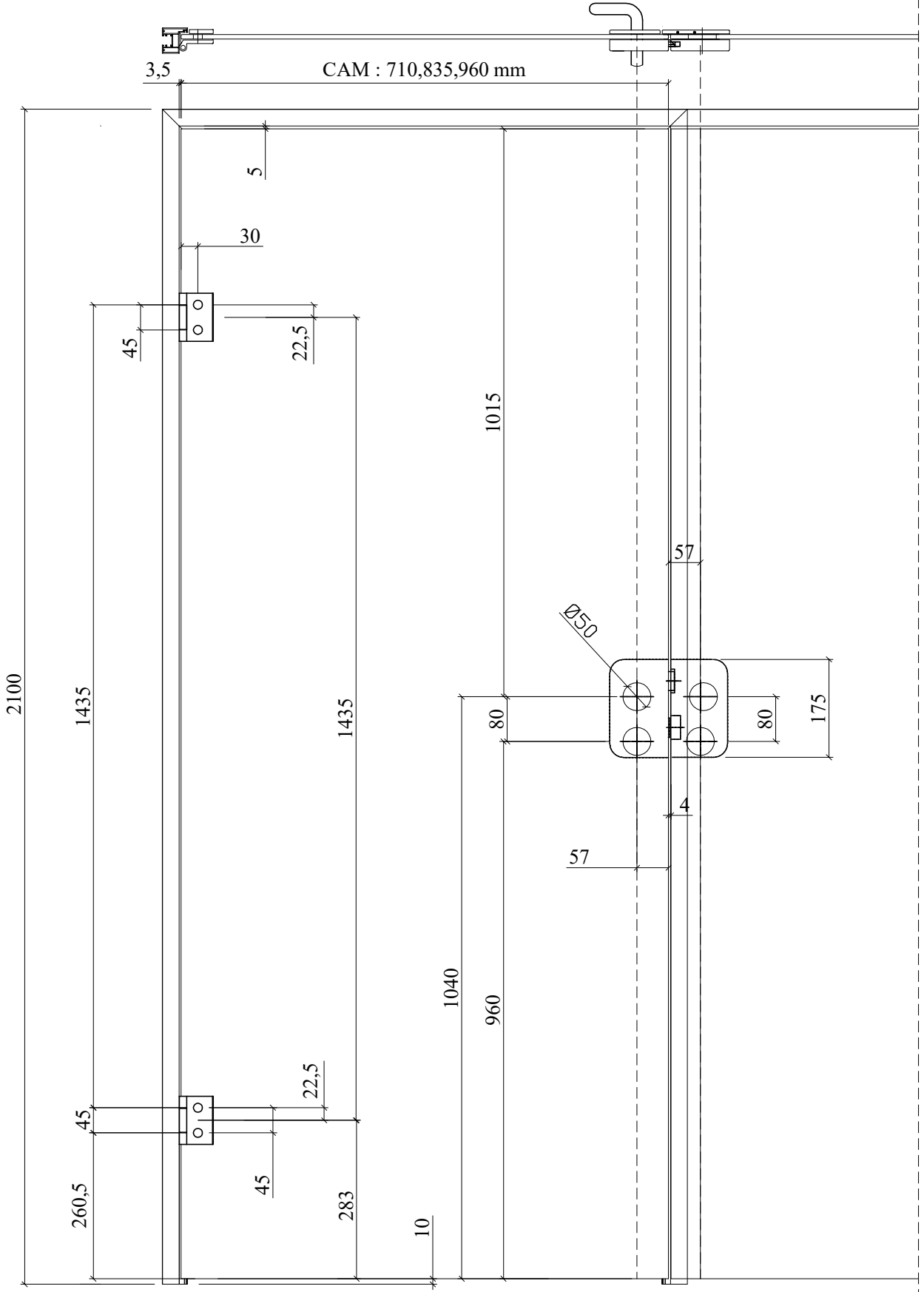

OB1-120
STRUKTUREL OFIS BOLME
VISION PARTITION

CAM TAKOZLARI
glass chocks

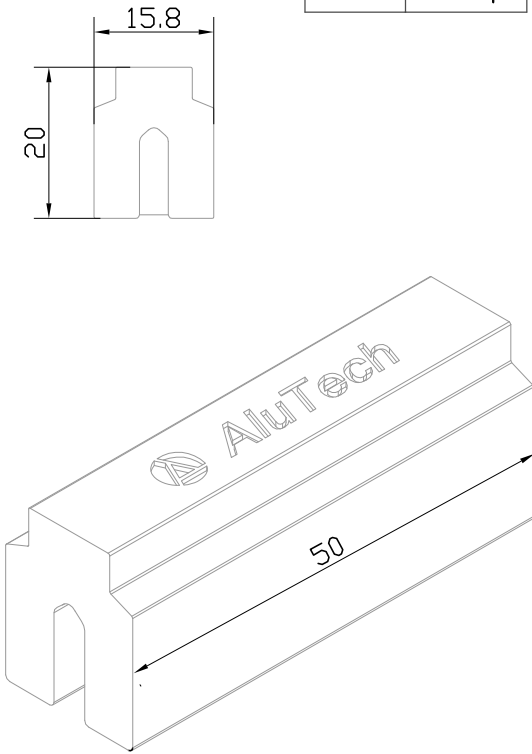
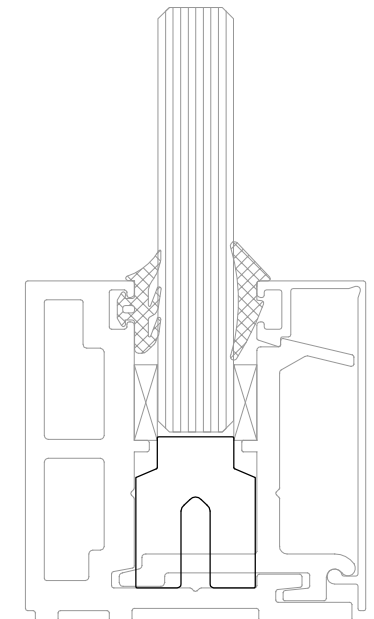
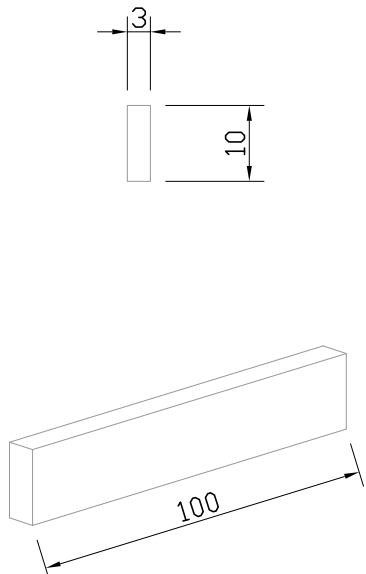
kod code	şekil drawing	tanım description	kullanım yeri aplication
OB4-500	<p>OB4-500 100 adet/pcs</p> 	Cam panel alt takozu lower glass panel chock	
OB4-501	<p>OB4-501 100 adet/pcs</p> 	Cam panel sıkıştırma takozu Glass panel compression wedge	